

**Solutions for Fluid Technology**



**OPERATING INSTRUCTIONS**

For Flow Meters of the Product Series "Ex-Type VS"



## TABLE OF CONTENTS

	<b>Page</b>
Important basic information . . . . .	3
General function description of flow meter for Ex-hazardous areas . . . . .	4
General description . . . . .	4
Flow meter selection . . . . .	4
Declaration of Conformity . . . . .	4
General conditions for initial start-up . . . . .	4
Maximum operating pressure . . . . .	5
Information on EU Directive 2014/68/EU On pressure equipment . . . . .	5
Flow meter range . . . . .	6
Assembly of the flow meter . . . . .	6
Cleaning and flushing of pipe lines before initial start-up . . . . .	7
Filtering of liquid . . . . .	7
Flow meter for explosion hazardous areas . . . . .	8
Isolated switching amplifier MK 13-P-Ex0/24 V DC/K15 . . . . .	9
Installation of VSE flow meters in explosion hazardous areas . . . . .	11
Safety instructions for installation and operation in explosion hazardous areas . . . . .	14
Maintenance, service life and warranty . . . . .	15
Storage, return and disposal . . . . .	15
Technical specifications VS 0.02 – VS 4 . . . . .	16
Flow response curves VS 0.02 – VS 4 . . . . .	17
Dimensions VS 0.02 – VS 4 . . . . .	18
Dimensions, subplates AP.02 - 4 . . . . .	19
Technical specifications VS 10 . . . . .	20
Flow response curves VS 10 . . . . .	20
Dimensions VS 10 . . . . .	21
Dimensions, subplate APG 10 . . . . .	21
Type key . . . . .	22
Labeling of the flow meters . . . . .	24
Safety data for flow meter type VS*** ***** -32Q1 */* . . . . .	24
Maximum ambient and media temperatures . . . . .	25
Preamplifier–block wiring diagram . . . . .	25
Summary of the safety-related technical data . . . . .	26
Certificates . . . . .	27
Certificate of Non-Objection . . . . .	36

The current publication of this operating instruction supersedes all information from previous publications. VSE reserves the right to make changes and substitutions. VSE is not liable for any printing errors. Reproduction, including excerpts, is permitted only after written approval by VSE. VSE reserves the right to modify technical data at any time. Last revised: 02/2022



## IMPORTANT INFORMATION AND LEGAL NOTICES

### **Dear customer, dear user,**

This operating instruction for volume sensors of the „Ex-Type VS“ series by VSE Volutentechnik GmbH (VSE) contains information required to properly install and commission the flow meter in potentially hazardous areas according to the regulations.

Any installation, commissioning, operation, maintenance and testing may only be carried out by trained and authorized personnel with knowledge of the national regulations relating to explosion protection. The operating instructions must be read and followed carefully to ensure a trouble-free, proper and safe operation of the flow meter. In particular, the safety instructions are essential.

These operating instructions must be kept safe and accessible for the authorized personnel at all times. At no time should contents of the operating instructions be removed. A missing manual or missing pages must be replaced immediately if lost. The operating instructions can be requested at any time from VSE or downloaded from our website [www.vse-flow.com](http://www.vse-flow.com). The operating instructions must be passed on to each subsequent user of the flow meter.

This operating instruction is not subject to any modification service by VSE. VSE reserves the right to make technical changes at any time without notice.

VSE makes no warranties, express or implied, with respect to commercial qualities and suitability for a particular purpose.

VSE accepts no liability for damage and malfunctions resulting from operating errors, failure to observe these operating instructions, improper installation, commissioning or maintenance as well as improper use of the flow meter.

The opening of the flow meter is absolutely not permitted. After an unauthorized opening or rebuilding as well as after a single, incorrect connection of the flow circuits of the flow meter, the warranty as well as the product liability by VSE expire.

## GENERAL FUNCTION DESCRIPTION OF FLOW METER FOR EX-HAZARDOUS AREAS

Flow meters made by VSE Volumentechnik GmbH measure the volume flow of liquids according to the toothed wheel principle. A pair of very precisely adjusted toothed wheels in the housing constitutes the meter. A signal pick-up system registers meter rotation free of contact and tooth by tooth. Each tooth is put out as digital pulse.

The gaps in the teeth of the meter wheels form meter chambers in the areas, in which they are completely enclosed by the housing walls; the-

se chambers digitalise liquid flow depending on their chamber volume. The liquid flow quantity within one meter rotation of a tooth division forms the volume measurement per pulse ( $V_m$ ) and is defined in  $\text{cm}^3/\text{pulse}$ . It identifies the constructional size of a flow meter.

The "Ex-type VS" generates two modulated digital current signals which are digitalized and amplified by isolation amplifiers.

## GENERAL DESCRIPTION

Please follow all instructions in this operating manual; only this guarantees a trouble-free operation of the flow meters. VSE is not liable for any damage ensuing from non-following of these instructions.

Opening the devices during the term of guarantee is only authorised after consultation and approval of VSE.

## FLOW METER SELECTION

The correct selection (version) of type and constructional size is crucial for a trouble-free and safe operation of the flow meters. Owing to the great number of various applications and flow meter versions, the technical specifications in the VSE catalogue material are of a general

nature. Performance of the flow meter depends on type, size and meter range and on the liquid that is to be measured. Please consult VSE for an exact description.

## DECLARATION OF CONFORMITY

Flow meters of the "VS" product line are tested for their electromagnetic compatibility and interference transmission in terms of the law on electro-magnetic compatibility and correspond to the legal prescriptions enforced by EMC directives. They may not be operated independently and are to be connected via cable to a power source and supply digital electric signals for electronic evaluation.

All flow meters are tested according to the valid, legally prescribed electromagnetic compatibility directives.

Since the electromagnetic compatibility of the total measuring system depends as well on cable layout, correct connection of protective shielding and each single connected device, you must ensure that all components correspond to the electromagnetic compatibility directives and that the electromagnetic compatibility of the total system, machine or plant is guaranteed.

"Ex-Type"-flow meters from VSE are authorized for use in explosion hazardous areas and comply with the safety requirements of the ATEX directive 2014/34/EU and the relevant European standards. These flow meters are certified by an accredited body. The certificate can be found in this operation manual. A copy of the declaration of conformity is to be supplied with each "Ex-Type" product that is delivered.

## GENERAL CONDITIONS FOR INITIAL START-UP

Before assembly and before initial start-up, you have to note the following properties and aspects of the corresponding characteristics of your system, so that a trouble-free and safe operation is possible.

### 1. The process fluid

- Is the flow meter **suitable for the fluid**?
- Is the fluid **viscous or abrasive**?
- Is the fluid **contaminated** or is there **solid matter in the fluid**?
- Which **granular size** does the solid matter possess and can it **block the meter**?
- Does the fluid have **fillers** or other **additional material**?
- Is it necessary to install a pre-switched **hydraulic filter**?
- Are the **pipe lines clean** and free of assembly residues such as swarf, weld chips?
- Is the **tank clean** and is it ensured that **no extraneous materials** can get into the pipe line system from the tank?
- Is the fluid often changed and is **sufficient flushing performed in this case**?
- Are the pipe lines and the entire system completely **deaerated**?
- What **cleaning agent** is being used?
- Are the fluid and the cleaning agent compatible with the **seals**?
- Are the **seals suitable** for the fluid undergoing measurement (**seal compatibility**)?

## 2. The hydraulic properties of the system

- Is the **max. operating pressure of the system** lower than the max. permitted operating pressure of the flow meter?
- Is the **max. fall of pressure  $\Delta p$**  (on flow meter) below the max. permitted fall of pressure?
- Does an excessively **great fall in pressure  $\Delta p$**  occur on the flow meter at max. flow (e.g. with higher viscosity)?
- Does the flow range of the flow meter (depending on viscosity) correspond to the **provided flow**?
- Note that flow range decreases the **greater the viscosity!**
- Does the temperature range of the flow meter correspond to the **provided max. temperature** of the medium?
- Is the **cross section** of the pipe line large enough and are the falls in pressure in the system not excessive?
- Is the **hydraulic connection** (supply and reverse flow) correctly connected and leak-proof?
- Has the **pump** sufficient power to operate the system?
- A blocking flow meter can stop the whole flow. Is a **pressure control valve / bypass** provided in the system?

## 3. Electronic evaluation and electrical safety

- Have you selected the optimal flow meter and is this equipped with the **appropriate preamplifier**?
- Does the **power supply voltage** of the flow meter correspond to the provided voltage?
- Is the power supply voltage supplied by the mains or evaluation device sufficiently **steady**?
- Does the **output** of the power supply voltage correspond to the required power output?
- Has the electric connection been installed based on the enclosed **connection plan**?
- Is the cable **protected** by a shielding?
- Is there a **connection** of the cable protective shielding via the 4-pin round plug to the housing of the flow meter?
- Is there a **potential difference** between the earth conductor connection PE on the flow meter and the earth conductor PE on the evaluation device?
- Does a compensating cable have to be laid to eliminate the **potential difference** between the flow meter and the evaluation device?
- Is the flow meter connected firmly to the **earth conductor PE** (e.g. via the pipe lines)?
- Is the flow meter mounted to be **insulated** to the earth conductor PE (e.g. connection via hoses)? If this is the case, the earth conductor PE has to be connected to the flow meter!
- Is the cable laid fault-free and the installation secured from input of **interference pulses**?
- Is the **round plug** of the connection cable firmly screwed together with the plug of the flow meter?
- Are the wires on the **evaluation device** correctly and properly connected?
- Are the wires on the **isolation amplifier** correctly and properly connected?
- Does the entire system correspond to the directives of the electromagnetic compatibility laws (**EMC**)?
- Have all local valid regulations, **applicable directives**, guidelines and background conditions of the **explosion protection and electromagnetic compatibility laws** been maintained and observed?
- Systems that can lead to personal injury through malfunction or failure are to be equipped with the **appropriate safety devices**. The functioning of these safety devices is to be checked at **regular intervals**.

## MAXIMUM OPERATING PRESSURE

Before assembling the flow meter, you have to test that the max. operating pressure of the system does not exceed the max. permitted operating pressure of the flow meter. Meanwhile, observe the top pressures that can occur, when operating the system.

The following operating pressures are permitted depending on flow meter version:

- Flow meter in grey cast iron version  $p_{\max} = 315 \text{ bar} / 4500 \text{ psi}$
- Flow meter in stainless steel version  $p_{\max} = 450 \text{ bar} / 6500 \text{ psi}$
- Flow meter in special version  $p_{\max} = \text{up to } 700 \text{ bar} / 10100 \text{ psi}$

### Important:

**Please consult VSE for all operating pressures > 450 bar / 6500 psi and for special versions.**



## INFORMATION ON EU DIRECTIVE 2014/68/EU ON PRESSURE EQUIPMENT

In terms of Article 2, No. 5 of the directive named above, VSE volume sensors are so-called "pressure-maintaining components" and this directive thereby relates to them.

VSE volume sensors must thereby comply with the technical requirements named in Section 4 of the directive in accordance with Article 4, Paragraph (1d), Piping according to Paragraph (1c).

Typically, the fluids measured fall into Group 2 in accordance with Article 13, Paragraph (1b). The volume sensors sold by VSE do not comply with the limit values defined under Article 4, Paragraph (1a).

The technical requirements on volume sensors from VSE are therefore limited to the criteria defined in Article 4, Paragraph (3). That means that the devices must be designed and manufactured in accordance with the good engineering practices prevailing in the member state. We hereby confirm this. The paragraph also states that these units may not bear the CE label named in Article 18.

A CE declaration of conformity is therefore not issued in accordance with 2014/68/EU.

The CE label of our volume sensors refers to Directive 2014/30/EU.

## FLOW METER RANGE

The flow meter range specified in the flow meter data sheet ( $Q_{\min}$  –  $Q_{\max}$ ) refers to the testing fluid "hydraulic oil" with a viscosity of 21 mm<sup>2</sup>/s at a temperature of 20°C. For this flow meter range, VSE specifies measurement accuracy of up to 0.3% of the measurement value and a repetition accuracy of 0.05%.

For fluids of lower viscosity (< 21 mm<sup>2</sup>/s) measurement accuracy deteriorates, while for fluids of higher viscosity (> 21 mm<sup>2</sup>/s) it can improve. Also note, however, that the flow meter range is restricted in case of higher viscosity (see „Technical specifications“).

### Important:

**Make sure that the specified maximum permitted operating pressure of the flow meter cannot be exceeded, whatever the operating mode of the system. Note the flow meter range that is dependent on the viscosity of the fluid to be measured.**



## ASSEMBLY OF THE FLOW METER

The flow meter should be mounted on an easily accessible location, so that dismantling for cleaning the meter presents no problem. Since flow meters can work in any installation position and flow direction, you can mount it on any location of your system that you wish. Take care when installing the flow meter that always liquid remains in the flow meter even at system standstill and that it can never run empty. The outflow of the flow meter should therefore always show a certain back pressure. In critical cases or when the pipe line is at standstill or standby and can run empty, we recommend installing an extra non-return valve in the outflow line.

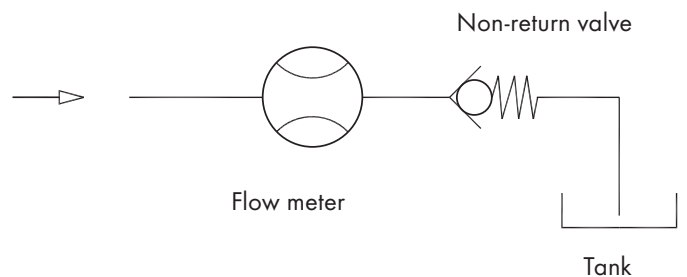

Fig. 1: Flow meter installation with non-return valve

### Important:

**Make sure that the flow meter is always completely filled both in inflow and outflow and that the outflow has a little back pressure. This prevents the meter being damaged by a sudden and steep increase of flow and at the same time improves measurement accuracy.**



Flow meters of the "VS" product line can be mounted directly onto a block or into the pipe line using four screws. Always select large cross sections for the hydraulic supply and return flow respectively for the entire pipe line system (if possible). This lowers the fall in pressure and the flow rate in the total system.

VSE supplies subplates for all flow meters of the "VS" product line; they have various pipe threads and side or rearside connection. Depending on the provided conditions, the installed pipe line, the pipe cross section or pipe thread, the operator can choose the suitable subplate and incorporate this into the system or machine without additional reductions.

The flow meter is screwed onto the block or subplate with four DIN 912 cheese head screws. The screws are to be evenly pre-tensed crosswise with the following torques.

When changing the fastening screws you must take great care that the screws are of property class 10.9 and 12.9.

Table 1: Torque of fastening screws

Flow meter, size (cast iron and 1.4305)	Torque
VS 0.02; VS 0.04; VS 0.1; VS 0.2	15 Nm
VS 0.4; VS 1; VS 2	35 Nm
VS 4	120 Nm
VS 10	250 Nm

**Important:**

**When mounting the flow meter, you must take great care that the seals are not damaged and correctly placed in the hydraulic connections of the flow meter. Wrongly installed or damaged seals lead to leakage and to an leaky system, which may have dire consequences.**

**Please make sure that flow meters with EPDM seals do not come into contact with oil and greases on a mineral oil basis. These fluids can decompose the seals.**

**The yellow plastic plugs in the hydraulic connections of the flow meter protect the meter against dirt and contamination during storage and shipping. Before mounting the flow meter you have to remove these plugs so that in- and outflow is free and open.**



## CLEANING AND FLUSHING OF PIPE LINES BEFORE INITIAL START-UP

Before initial start-up of the flow meter, you must flush and clean the whole system. Contaminated fluids can affect the correct function of the flow meter or seriously damage the meter.

After preparing and connecting up the system pipes, you must first carefully flush and clean the whole pipe line system and the tank. To do this, you have to mount a diversion plate onto the block or subplate instead of the flow meter, so that the fluid can flow through the diversion plate and all extraneous material (e.g. swarf, metal chips, etc.) can be flushed out without obstruction. Use a fluid as cleansing agent, which is compatible with the fluid being used later and which does not cause undesirable reactions. You can consult the suppliers and manufacturers of the fluid or contact VSE for the corresponding information. VSE supplies bypass-plates the corresponding for all VS flow meter sizes.

Flow meters are measurement pick-up systems made with high-level precision. They have a mechanical meter consisting of two toothed wheels and which is adapted to the housing with narrow slots. Even the tiniest damage to the toothed wheels and bearings can cause a measurement error. So always make sure that no extraneous material gets into the meter and that the fluid flowing through is always free from dirt and contamination.

After the system has been carefully flushed out and no extraneous material is in the pipe line, you can mount the flow meter and commence the initial start-up.

**Important:**

**Please flush out the pipe lines and the tank thoroughly, to prevent contamination with the flow meter.**



## FILTERING OF LIQUID

Strongly contaminated fluid or extraneous material in the fluid can block, damage or even destroy the flow meter. Always install a sufficiently large filter for these cases in front of the flow meter to prevent damage. The necessary filtering depends on size, bearing system and version of flow meter.

**Table 2: Pre-switched filters**

Flow meter size	Filter size for ball bearings
VS 0.02 / 0.04 / 0.1	10 µm
VS 0.2 / 0.4	20 µm
VS 1 / 2 / 4 / 10	50 µm

*For information on filter size for flow meters with plain bearings, in special version, or with specially adjusted meter tolerances, please consult VSE Volumentchnik GmbH.*

**Important:**

**A blocking flow meter can stop the whole flow. You have to provide a control valve / bypass for the system.**



## FLOW METER FOR EXPLOSION HAZARDOUS AREAS

The operation of flow meters in areas with a hazard of explosion is subject to very specific legal regulations. For this reason, only flow meters with a registered certification are permitted to be used in explosion hazardous areas.

To protect people from harm and equipment from damage, national and international regulations must be followed when using electrical components and systems in explosion hazardous areas.

Danger of explosion can arise when handling flammable substances. A hazardous situation occurs when these gaseous substances mix with oxygen have reached a dangerous level.

In this case a potential source of ignition like sparks or higher temperatures can lead to an explosion, which can injure people and damage plants or buildings.

All electrical devices which are used in explosion hazardous areas must be approved and marked for the relevant Ex-zone.

The Ex-zone classification depends on the frequency and duration of the explosive atmosphere and must be specified by the operator of the plant.

Ex-Type flow meters from VSE are suitable for intrinsically-safe "ia/IS" circuits and are certified for Zone 0/Division 1 (gas). They must always be operated with isolation preamplifiers. The special isolation preamplifiers which are supplied from VSE, provide the intrinsically safe "ia/IS"-circuits and are certified as associated electrical apparatus.

Intrinsically safe and non-intrinsically safe circuits must always be wired separately.

You can find relevant connection diagrams under "Installation of VSE flow meter in hazardous areas".

The Ex-Type VS is approved for EX ia IIC T6...T4 (ATEX) and for IS CL1 Div. 1 GRPS A, B, C, D T4 ... T6 (FM).

The permitted ambient and media (fluid) temperatures for the Ex-Type VS flow meter are classified for the corresponding temperature classes (T4, T5 or T6) and must be observed!

Please see "Maximum ambient and media temperatures".

The system Ex-Type flow meter and isolation amplifier is based on intrinsically safe circuits. The devices are approved by authorised bodies for use in those countries to which the approval applies.

For correct usage in explosion hazardous areas please observe and follow the national regulations and directives strictly. Following please find some guidelines referring to the actual frame-work directive of the European Union (ATEX), of the US (NEC) or of the corresponding country.

The special "TURCK"-isolation amplifier which are delivered by VSE, are classified as associated apparatus which are equipped with intrinsically safe and non-intrinsically safe circuits. They may only be installed in the non-explosion hazardous area in dry clean and well monitored locations.

The Ex-type flow meter is wired to the blue intrinsically safe terminals of the preamplifiers as intrinsically safe equipment. Please note: Once that intrinsically safe circuits have been connected to the non-intrinsically safe circuit, it is not permitted to use the device subsequently as intrinsically safe equipment. Each channel of the Ex-Type VS must be operated by one isolation preamplifier.

The VSE-Cable for the intrinsically safe circuits is also marked with blue color. It must be separated from the non-intrinsically safe circuits. Please observe the specified clearances between the intrinsically safe connections and the grounded components and connections of other devices.

If the flow meter or an isolation preamplifier is opened by a person other than the manufacturer the approval becomes void.

### Important:

**The installation and connection of the Ex-Type flow meter and the isolation amplifier are only to be performed by trained and qualified personnel with knowledge of the relevant national regulations to explosion protection.**

**The most important data of the Ex-Type flow meter can be found under the corresponding "Safety data" of this manual.**





### ISOLATION AMPLIFIER MK 13-P-EX0/24VDC/K15

The isolation amplifier MK13-P-Ex0/24VDC/K15 from "TURCK" allows electrically isolated transmission of digital impulses. The intrinsically circuit is electrically isolated from the output circuit and the supply voltage.

The PNP-output stages of the isolation amplifiers provide the digital impulses for further evaluation.

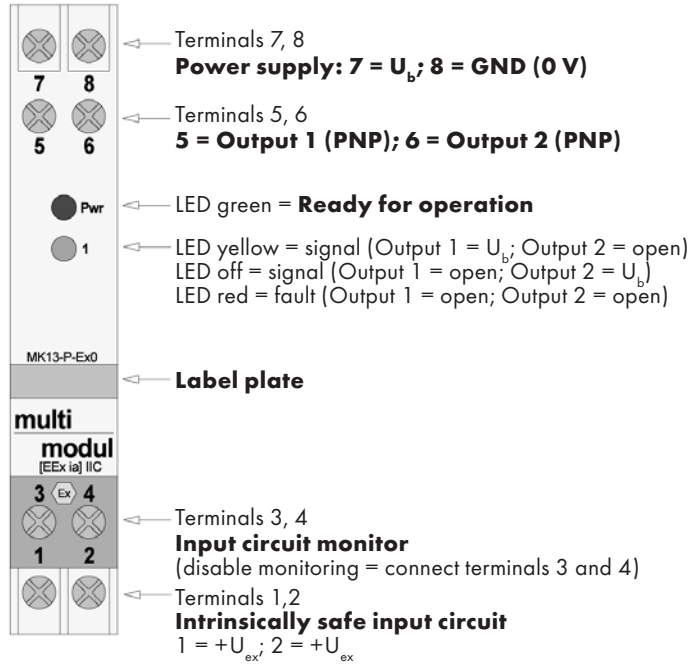

Figure 2: View of the isolation amplifier MK 13-P-Ex0/24 V DC/K15

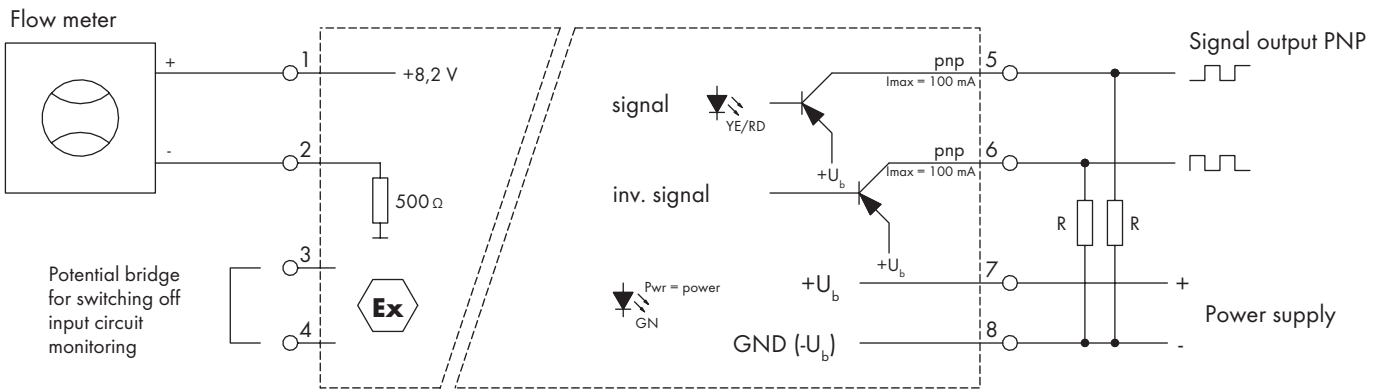

Figure 3: Circuit diagram of the isolation amplifier MK 13-P-Ex0/24 V DC/K15

The Ex-Type VS flowmeter outputs digital current modulated signals ( $I_{low} < 2.7\text{ mA}$ ;  $I_{high} > 3.7\text{ mA}$ ), which are processed in the isolation amplifier.

The digital current modulated signals are transmitted only by two wires for each channel. From these signals the isolation amplifiers create positively switching output signals (PNP-signals).

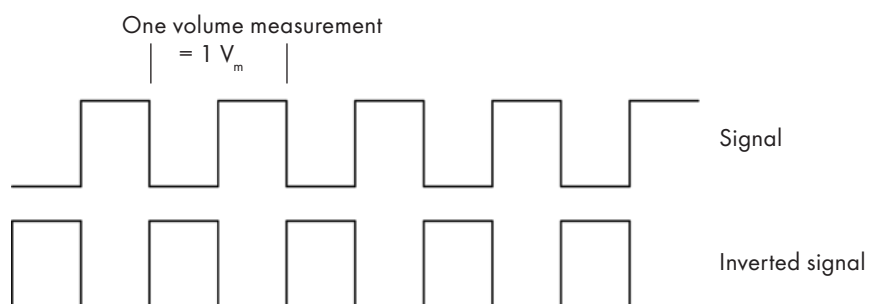

Figure 4: Signal output of the isolation amplifier

**Note:**

**Note that the signal output of the isolation amplifier is a PNP-signal (low signal = open output; high signal =  $U_b$ ). Problems may arise, when the signal processor has high impedance inputs, especially in the higher range of flow rates. The signal edges become rounded, and the signal processor cannot detect the digital signal any more. In this case, insert a pull-down resistor with a resistance of approx. 2.2 – 4.7 k $\Omega$  parallel to the input of the signal processor (see figure 3; Resistor R).**



**Information:**

**The Technical data for the isolation amplifier MK 13-P-Ex0/24 V DC/K15 from „TURCK“ you find in the enclosed leaflet.**

## INSTALLATION OF VSE FLOW METERS IN EXPLOSION HAZARDOUS AREAS

The following figures show the connection diagrams for Ex-Type VS flow meters for use in areas subject to an explosion hazard. Please connect each piece of equipment as shown in the diagram. Isolation amplifiers also contain non-intrinsically-safe circuits and may not be installed in hazardous areas.

VSE supplies connection cables for EMC-safe operation in which the shield is seated on the union nut of the four-pin circular connector. It is not necessary to connect the shield to a ground connection at the other end of the connection cable, but it is recommended.

You must always make sure that the grounded conductor "PE" is correctly connected with the flow meter and that no voltage differences can arise between the grounded conductor PE connections (flow meter » isolated switching amplifier » electronic signal processor). To accomplish this, always install an extra wire connection (about  $\varnothing 4 \dots \varnothing 6 \text{ mm}^2$ ) between each of the pieces of equipment (see the PE arrows in the following figures) or connect every single PE connection point in a star configuration to a specific location on the grounded conductor PE. There is a terminal for this on the flow meter. A conductor with a minimum diameter of  $4 \text{ mm}^2$  can be connected here.

**Important:**  
**Mounting and installation must always be performed according to the locally applicable regulations and the operator of the plant is responsible for ensuring that these regulations are complied with.**  
**You must make sure that no voltage differences can arise between the pieces of equipment and must install potential equalization!**  
**Please particularly observe the safety instructions in this manual.**



The connection diagram in figure 5 shows the processed signal of one channel from the flow meter. With this measuring system you can measure the flow rate and the volume, but it is not possible to detect the direction of flow, when connected in this manner.

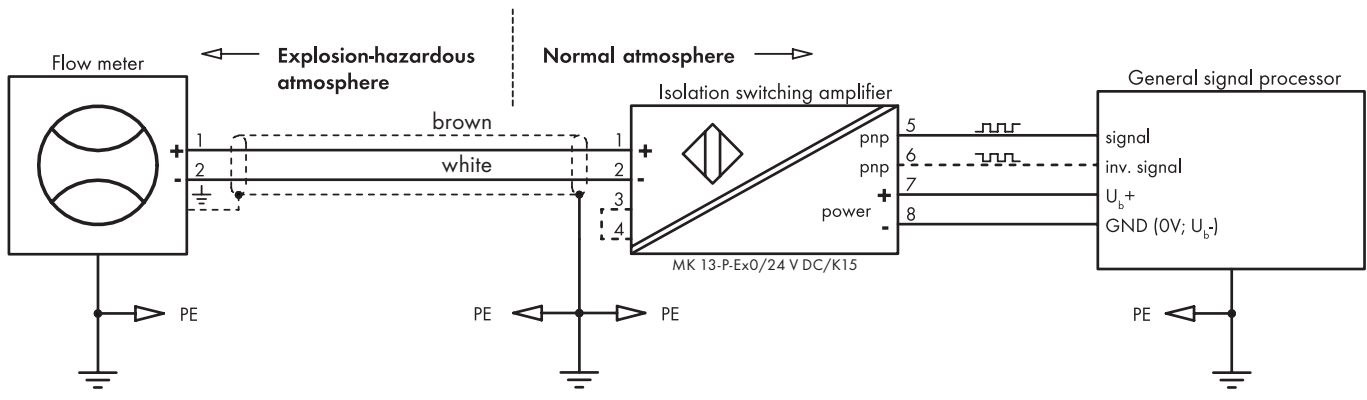



Figure 5: Evaluation of one channel

**Important:**  
**This processing unit can be used when it is ensured that the flow volume can flow in only one direction. When the flow direction changes (also short term), the receiver does not perceive this return flow, and a measurement error occurs.**



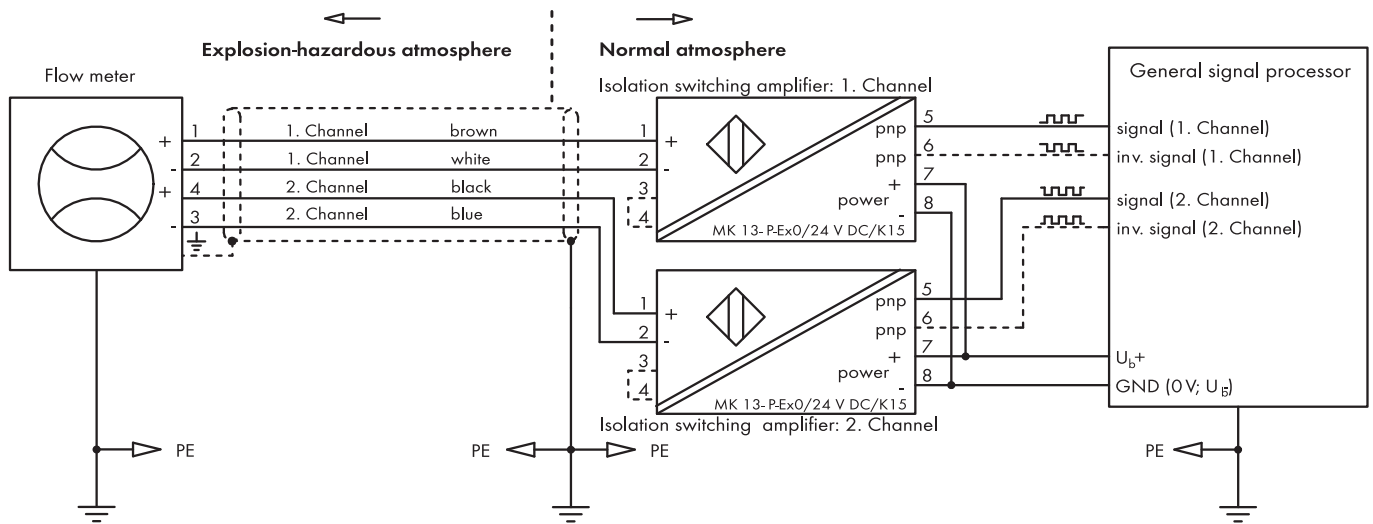

Figure 6: Evaluation of two channels (standard circuit) with direction detection

Usually this circuit is used as the standard. The read-out unit processes the digital signals from channels 1 and 2 and supplies the power. The inverted signals of the channels are not required for the evaluation. With this measuring system, you can measure the flow rate and volume in both directions of flow. You only need a four-strand cable.

With the figure 7 circuit, you can create two autarchic functioning signal systems. The Ex-Type of flow meter has two galvanic isolated circuits, which operate separately, thus allowing a separate processing of the signals (channel 1 and channel 2). As you can see in figure 7, the signals are transmitted through isolation amplifiers, which operate separately. The two systems are fed by two sources of power. Since the two signal systems are galvanically isolated from one another and operate independently, this type is used in equipment and systems, which operate redundantly. Even if one of the signal systems fails, the other continues to function.

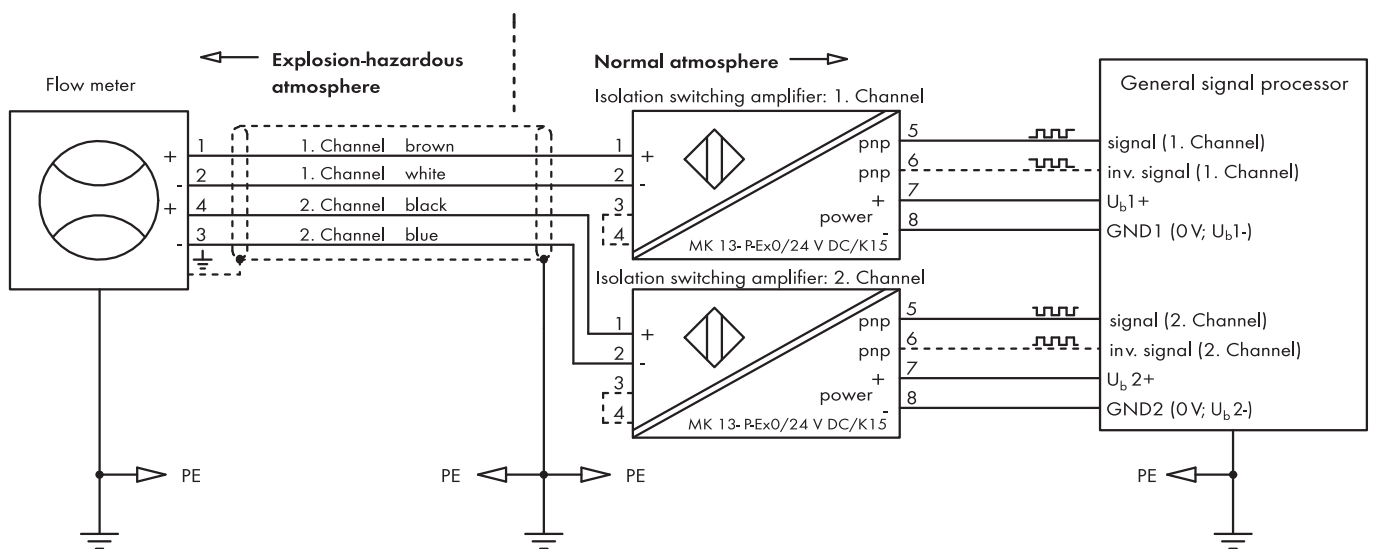



Figure 7: Galvanic isolation between the channels through separate power supply

**Important:**  
**The isolation switching amplifier MK13-P-Ex0/24 V DC/K15 is manufactured by WERNER TURCK GmbH & Co. KG exclusively for the Ex-Type flow meters of VSE Volumentechnik GmbH!**



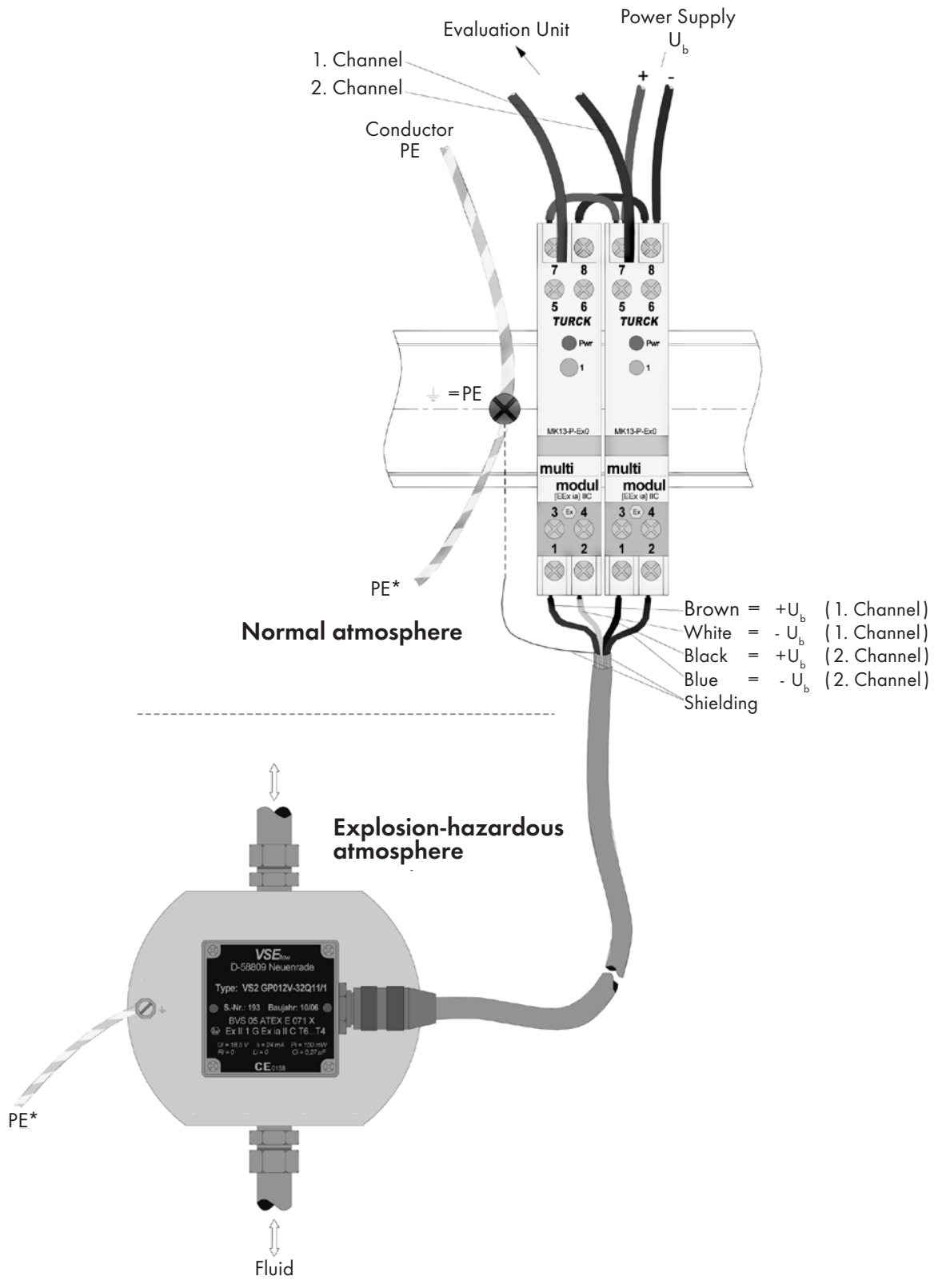

Figure 8: Connection of flow meter and isolated switching amplifier

**Important:**  
Persons assigned or contracted to install, commission and operate the devices must have relevant qualifications for the job. In particular, they must have knowledge of explosion protection.



## SAFETY INSTRUCTIONS FOR INSTALLATION AND OPERATION IN HAZARDOUS AREAS

1. Only qualified personnel, meaning authorized persons with special explosion protection training, are permitted to install explosion-protected equipment and systems.
2. The qualified personnel must have read and understood the installation regulations and the corresponding type Examination Certificates and Declarations of Conformity.
3. Work may only be done on the devices in a de-energized state.
4. Before you operate the flow meter, you must carefully clean and rinse the entire system so that no foreign particles from the installation can get into the measuring unit of the flow meter.
5. The pipes and the flow meter must always be filled in operation so that no gas bubbles can form.
6. Extremely dirty media or foreign particles in the medium can block, damage or even destroy the measuring unit. In these cases you should always install a sufficiently rated filter ahead of the flow meter so that no foreign particles or substances can get into the measuring unit and damage the flow meter.
7. The permissible ambient and media temperatures in the corresponding temperature class may not be exceeded at any time, when operating the flow meter.
8. You may not change or extend the devices in any way, if the modifications were not expressly permitted by the manufacturer. If the preamplifier or isolation amplifier housing is opened, then the explosion protection certification becomes invalid.
9. The VSE flow meters are not authorized for use in areas subject to a dust explosion hazard.
10. To suppress inductive interference, you must use a connection cable in which the shield is seated on the union nut of the four-pin circular connector. In Ex-hazardous areas, the flow meter is connected to a ground potential. You must be extremely certain that there is an equalization of potential between each end of the circuit. The potential equalization of the ground conductor PE must be present throughout the entire area.
11. The operator of the plant must maintain the system in proper operating condition, operate the system properly, monitor it constantly, perform the necessary maintenance and any related work immediately, and follow the relevant safety regulations, when doing so. This procedure, known as continuous monitoring, will eventually be adopted as a new law of the corresponding country.
12. VSE supplies special flow meters from the VS series, when the flow meter is to be operated in a Ex-hazardous area. These flow meters are authorized for use in Ex-hazardous areas and must always be operated in conjunction with isolated switching amplifiers that guarantee intrinsic safety and are Ex-certified. The intrinsically safe circuits are marked in blue and offer the safety level required for explosion protection.
13. The isolation amplifier must guarantee the "ia/IS" level of intrinsic safety of the signal circuit, and their limit values may not exceed the highest permitted input value of the flow meter.
14. When equipment is connected electrically, a "Verification of Intrinsic Safety" must be performed according to the actual regulations and standards. Even if an intrinsically safe circuit is connected just once to a non-intrinsically safe circuit, then the piece of equipment is not authorized for use anymore as a device with intrinsically safe circuits. This applies to the isolation amplifiers as well as the flow meters. The relevant, applicable regulations apply to the installation of intrinsically safe circuits, the mounting of external connectors, the properties and routing of lines and cables. Cables and terminals with intrinsically safe circuits must be labeled accordingly and must be isolated from non-intrinsically safe circuits or be equipped with appropriate isolation according to the actual standards.
15. The sum of the maximum effective capacitance  $C_i$  and inductivity  $L_i$  of the flow meter and the four-pin connection cable may not exceed the maximum values  $C_0 (C_a)$  and  $L_0 (L_a)$  of the corresponding isolation amplifier. Pay attention to the manufacturer's specifications for the connection cable and to the lengths of the cables used.
16. It must be especially observed that the radial thickness of the insulation of a conductor have a minimum thickness of 0.2 mm. The diameter of a finely stranded conductor must not be smaller than 0.1 mm. The ends of the conductor have to be protected against fanning out, e.g. by ferrules.  
In addition to this the sheath insulation must be tested in respect of electrostatic charge to ensure a safe use in the intrinsically safe area. The VSE-Ex-cable corresponds to these requirements.
17. It must be especially observed that for the use of devices with two channels there exist two intrinsically safe power circuits in a cable. Here please observe the corresponding regulations and standards (e.g. EN60079-14; part 12.2.2.7/8). An installation firm and protected against damages is always necessary for this kind of operation.
18. When operating or performing maintenance or repairs on the flow meter, the surface of the flow meter housing must be safely protected from impact or sharp edges, tools or other items.
19. The flow meter parts contain shares of aluminum, magnesium, titan and /or zirconium. The generation of impacts and friction, especially between different metals, must be prevented so that the production of sparks is ruled out.
20. When using the flow meters (Ex-Type VS) in Ex-hazardous areas requiring category 1 equipment, the flow meter is to be installed so that sparks from impact or friction can be ruled out.
21. The marking on the typeplate must stay readable.



## MAINTENANCE, SERVICE LIFE AND WARRANTY

Depending on the operating conditions, the service life and therefore the specific properties of the units are limited by wear, corrosion, deposits or ageing. The operator is responsible for regular inspection, maintenance and recalibration. Any observation of a malfunction or damage prohibits further use. On request, we can provide you with a

loan unit for the duration of the overhaul. We recommend an annual check and recalibration. Under normal operating conditions, the service life is 10,000 hours.

The warranty period is 12 months.

## STORAGE, RETURN AND DISPOSAL

### Temporary storage

All VSE flow meters are supplied with sealing plugs and in suitable packaging for all destinations and modes of transport to ensure optimum protection. The flow meters should always be stored in their original foam packaging or transport box.

The units must not be exposed to temperatures below  $-20^{\circ}\text{C}$  or above  $+60^{\circ}\text{C}$  and must be protected from moisture and its effects.

### Return

1. The flow meter must be properly cleaned by the customer before being returned to prevent the risk of poisoning/contamination by harmful, explosive and other high-risk pumped media for humans and the environment.
2. If media have been conveyed whose residues with atmospheric humidity lead to corrosion damage or ignite on contact with oxygen, the flow meter must be additionally neutralised and thoroughly cleaned with anhydrous, inert gas to dry.
3. The return of the flow meter must always be accompanied by a fully completed declaration of no objection (see page 36). All applied safety and decontamination measures must be indicated.
4. When returning the flow meter, it must be packed in accordance with the applicable logistics standards and sealed with sealing plugs.

### Disposal

VSE actively promotes environmental awareness and has an operational management system that meets the requirements of ISO 9001:2015. The impact on the environment and people should be minimised during the production, storage, transport, use and disposal of our products and solutions.

- Collect rinsing liquid as well as residual liquid and dispose of it in accordance with the statutory provisions and regulations.
- Wear protective clothing and protective mask/+ goggles if necessary.

Materials must be disposed of properly as follows:

- Metal
- Plastics
- Electronic components
- etc.

When disposing of the materials, ensure that the waste-relevant rules and regulations of the respective country of destination are observed!

## TECHNICAL SPECIFICATIONS VS 0.02 – VS 4

Size	Measuring range l/min	Frequency Hz	Pulse value cm <sup>3</sup> /pulse	K-factor pulse/litre
VS 0.02	0.002 ... 2	1.667 ... 1666.67	0.02	50 000
VS 0.04	0.004 ... 4	1.667 ... 1666.67	0.04	25 000
VS 0.1	0.01 ... 10	1.667 ... 1666.67	0.1	10 000
VS 0.2	0.02 ... 18	1.667 ... 1500.00	0.2	5 000
VS 0.4	0.03 ... 40	1.250 ... 1666.67	0.4	2 500
VS 1	0.05 ... 80	0.833 ... 1333.33	1	1 000
VS 2	0.1 ... 120	0.833 ... 1000.00	2	500
VS 4	1.0 ... 250	4.167 ... 1041.67	4	250

<b>Measurement accuracy</b>	up to 0.3% of measurement value (with viscosity > 20 mm <sup>2</sup> /s)	
<b>Repeating accuracy</b>	± 0.05% under the same operating conditions	
<b>Materials</b>	Cast iron EN-GJS-400-15 (EN 1563) or Stainless steel 1.4305	
<b>Gear bearing</b>	Ball bearings or steel plain bearings (medium-dependent)	
<b>Seals</b>	FPM (standard), NBR, PTFE or EPDM	
<b>Max. operating pressure</b>	Cast iron EN-GJS-400-15 (EN 1563)	315 bar / 4500 psi
	Stainless steel 1.4305	450 bar / 6500 psi
<b>Viscosity range</b>	1 ... 100 000 mm <sup>2</sup> /s	
<b>Installation position</b>	any	
<b>Direction of flow</b>	any	
<b>Running noise</b>	max. 72 db(A)	
<b>Channel offset</b>	90° ± 30° max.	
<b>Pulse-width repetition rate</b>	1/1 ± 15° max.	
<b>Preamplifier housing</b>	Aluminum	
<b>Protection type</b>	IP 65	



**VS 0.02**

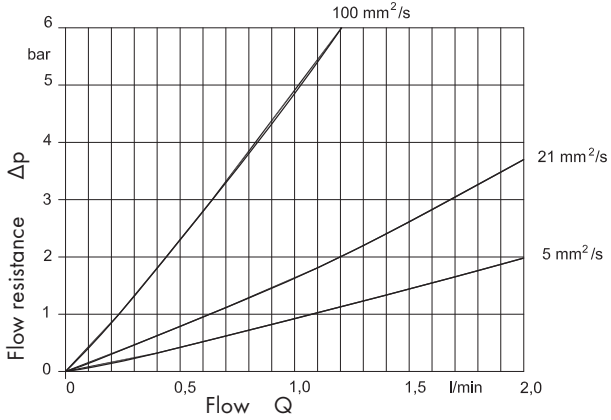

**VS 0.04**

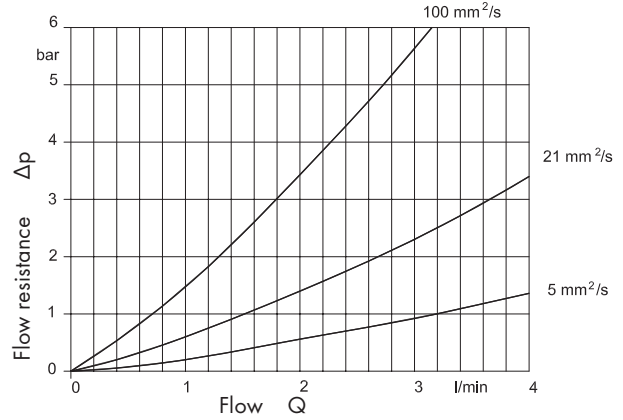

**VS 0.1**

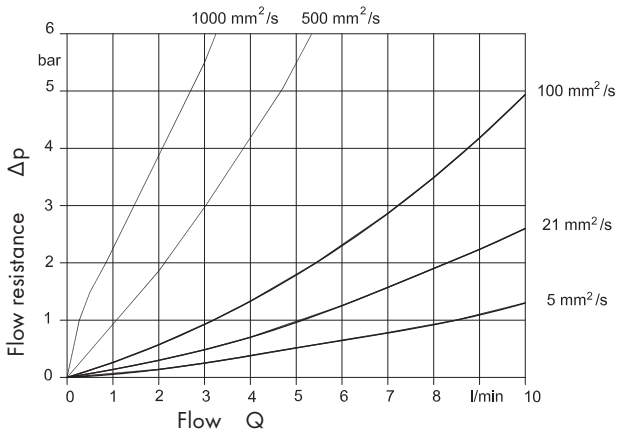

**VS 0.2**

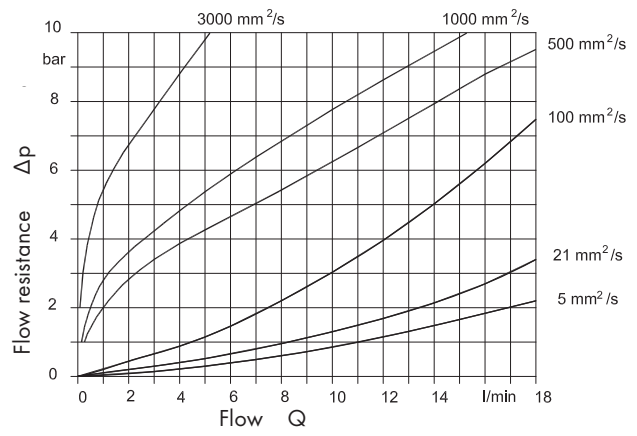

**VS 0.4**

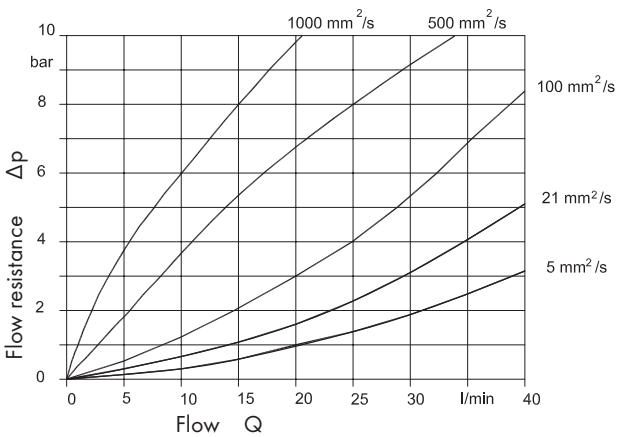

**VS 1**

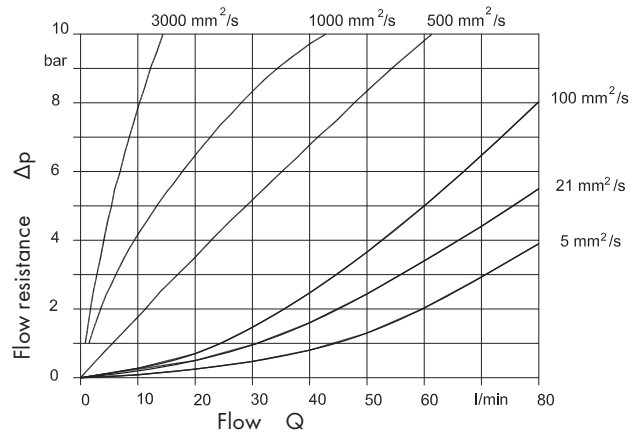

**VS 2**

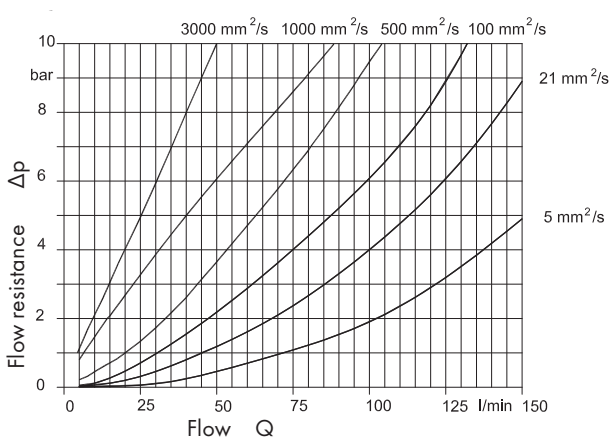

**VS 4**

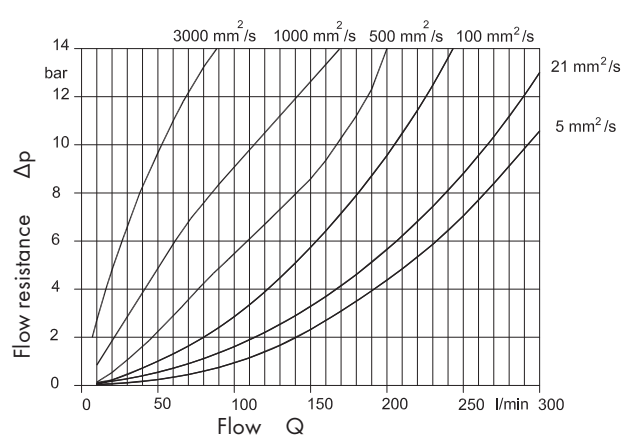

**DIMENSIONS VS 0.02 – VS 4**

Cast iron version

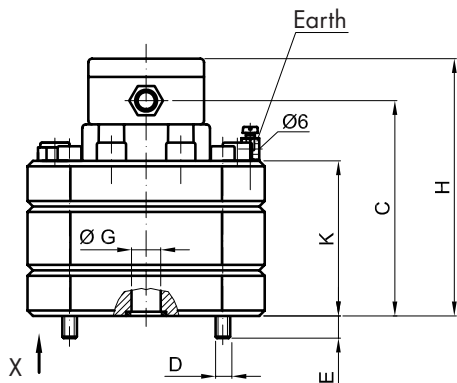

View X

Stainless steel version  
Connection diagram  
Housing without milled edge

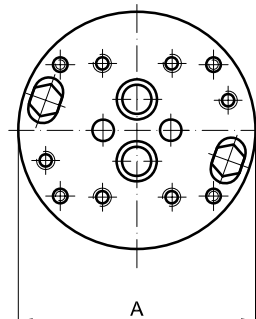

Centering bore hole

Plug position for VS 0.02 to VS 0.4 and VS 4

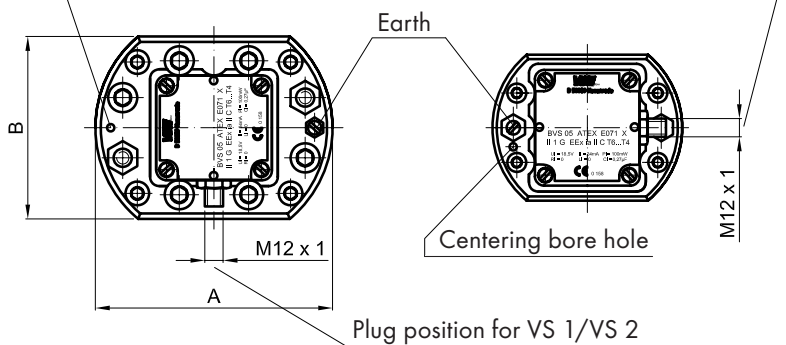

View X

Cast iron version  
Connection diagram

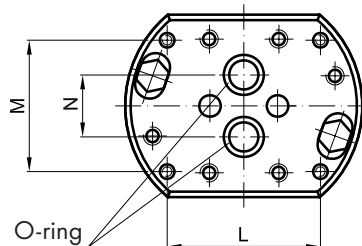

Size	A	B	C	D	E	øG	H	K	L	M	N	O-ring	weight GCI kg	E kg
<b>VS</b>														
0.02	100	80	91	M6	12	9	114	58	70	40	20	11 x 2	2.8	3.4
0.04	100	80	91.5	M6	11.5	9	114.5	58.5	70	40	20	11 x 2	2.8	3.4
0.1	100	80	94	M6	9	9	117	61	70	40	20	11 x 2	2.8	3.4
0.2	100	80	93.5	M6	9.5	9	116.5	60.5	70	40	20	11 x 2	3.0	3.7
0.4	115	90	96.5	M8	11.5	16	119.5	63.5	80	38	34	17.96 x 2.62	4.0	5.0
1	130	100	101	M8	12.5	16	124	67.5	84	72	34	17.96 x 2.62	5.3	6.8
2	130	100	118	M8	15	16	141	85	84	72	34	17.96 x 2.62	6.7	8.4
4	180	140	143	M12	20	30	166	110	46	95	45	36.17 x 2.62	14.7	18.4

The dimensions are specified in mm

### DIMENSIONS, SUBPLATES AP. 02 - 4

Connection position, side

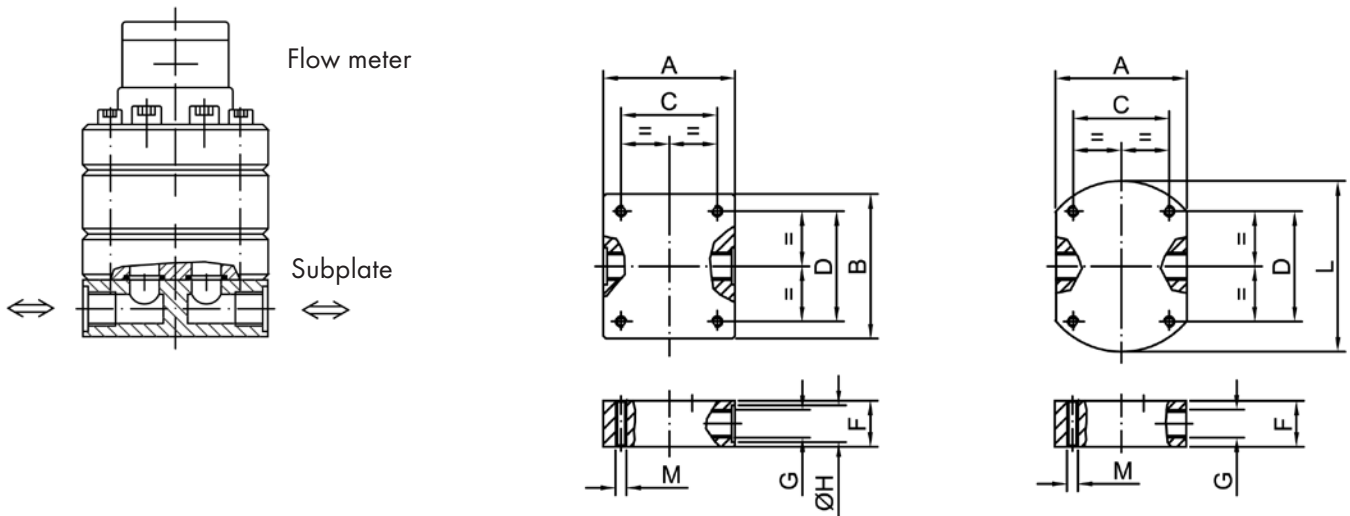

Size	Connection thread	F	øH	A	B	C	D	E	L	Thread /depth	weight
<b>VS</b>	<b>G</b>									<b>M</b>	<b>kg</b>
0.02	G 1/4"	35	20	80	90	40	70	26	100	M6 / 12	1.8
0.04	G 3/8"		23					30			
0.1	G 1/2"		28					38			
0.2											
0.4	G 1/2"	35	28	90	100	38	80	46	115	M8 / 15	2.7
	G 3/4"	40	33					52			
1 2	G 1/2"	35	28	100	110	72	84	46	130	M8 / 15	3.6
	G 3/4"	40	33					52			
	G 1"	55	41					55			
4	G 1 1/4"	70	51	120	130	100	110	60	M8 / 15	7.4	
	*G 1 1/2"	70	56	140			120	72		180	12.0
	G 1 1/2"	80					110				

\*only for AP. 4 U...

Connection position below

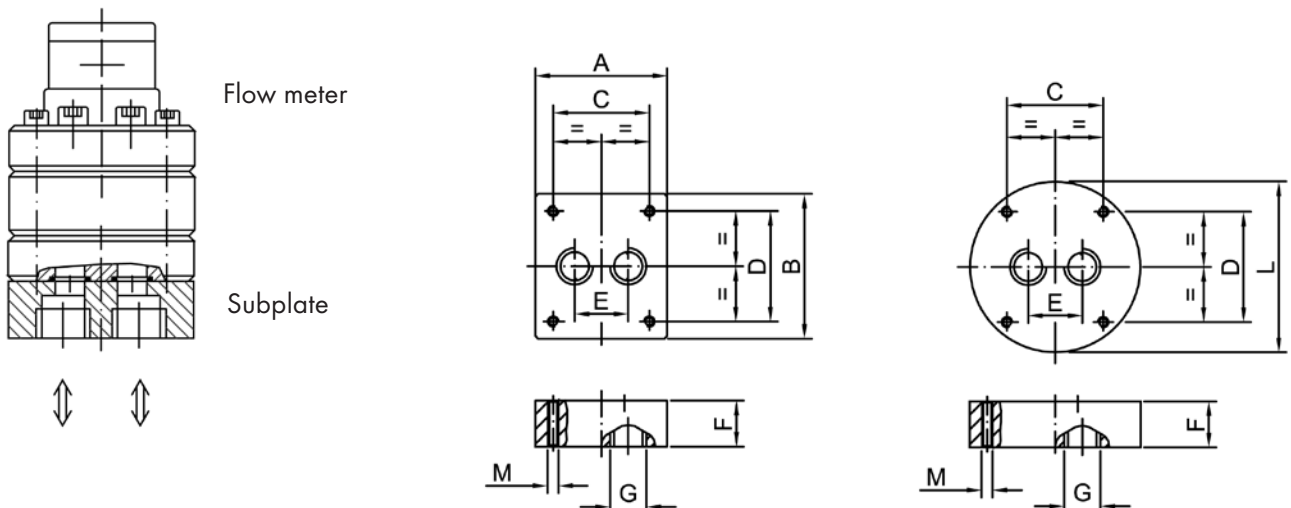

## TECHNICAL SPECIFICATIONS VS 10

Size	Measuring range l/min	Frequency Hz	Pulse value cm <sup>3</sup> /pulse	K-factor pulse/litre
VS 10	1.5 ... 525	7.50 ... 2625.00	3.333	300

Measurement accuracy	up to 0.3% of measurement value (with viscosity > 20 mm <sup>2</sup> /s)
Repeating accuracy	± 0.05% under the same operating conditions
Materials	Cast iron EN-GJS-600-3 (EN 1563)
Gear bearing	Ball bearings or steel plain bearings (medium-dependent)
Weight	70 kg without subplate
Seals	FPM (standard), NBR, PTFE or EPDM
Max. operating pressure	400 bar / 6000 psi
Viscosity range	1 ... 100 000 mm <sup>2</sup> /s
Installation position	any
Direction of flow	any
Running noise	< 80 db(A)
Channel offset	90° ± 30° max.
Pulse-width repetition rate	1/1 ± 15° max.
Preamplifier housing	Aluminum
Protection type	IP 65

## FLOW RESPONSE CURVES VS 10

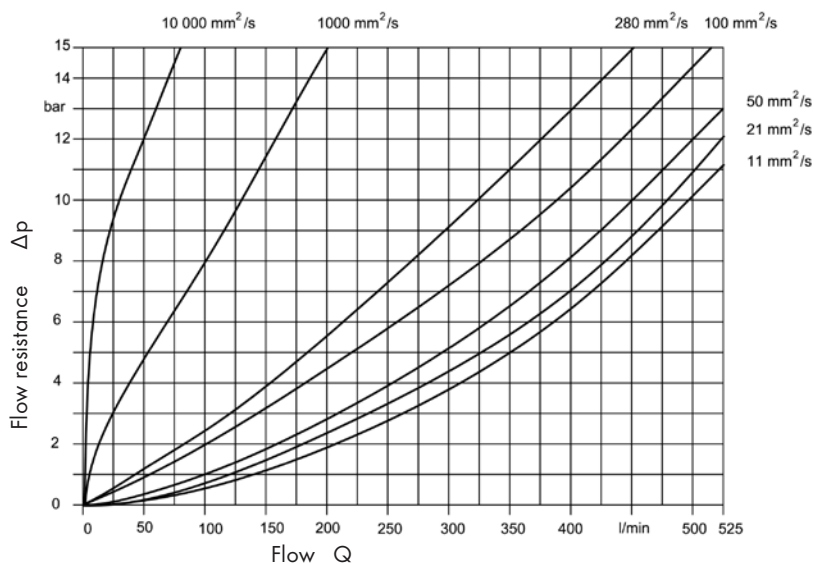

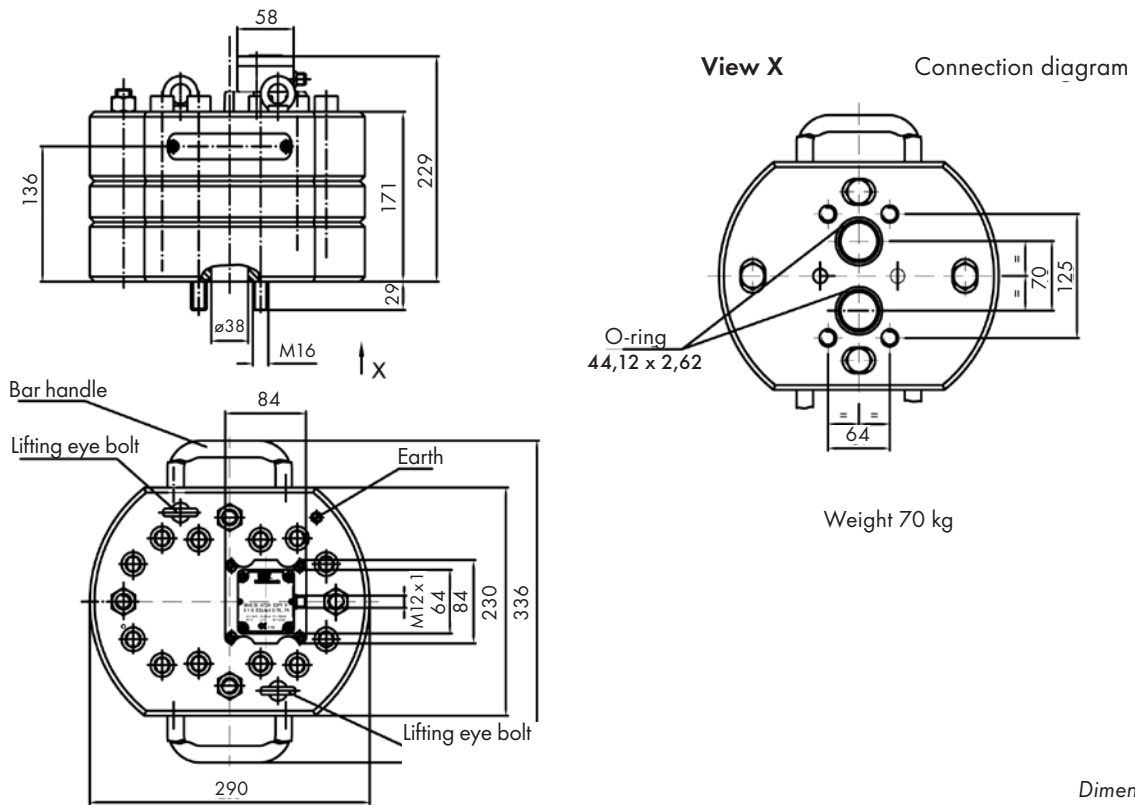

**DIMENSIONS, SUBPLATE APG 10**  
APG 10 SG0N / 1

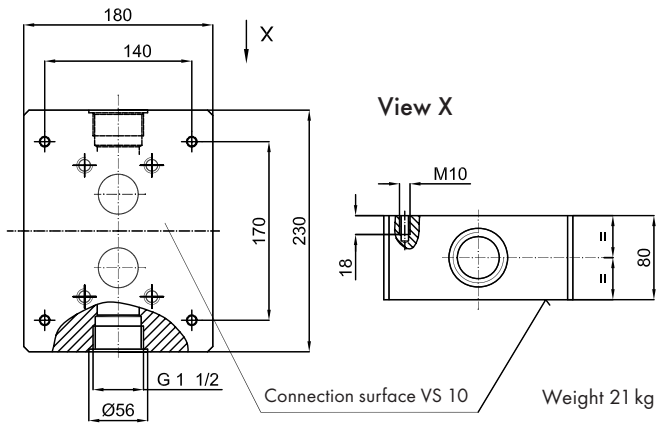

**APG 10 SW0N / 1**

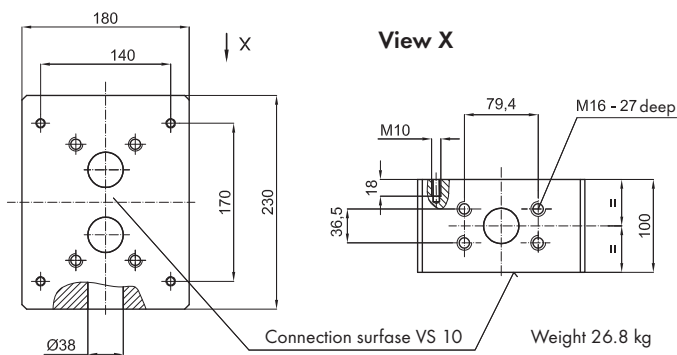

# TYPE KEY

## Flow meters VS Ex-Type

Example

**VS1 GP012V-32Q11/1**

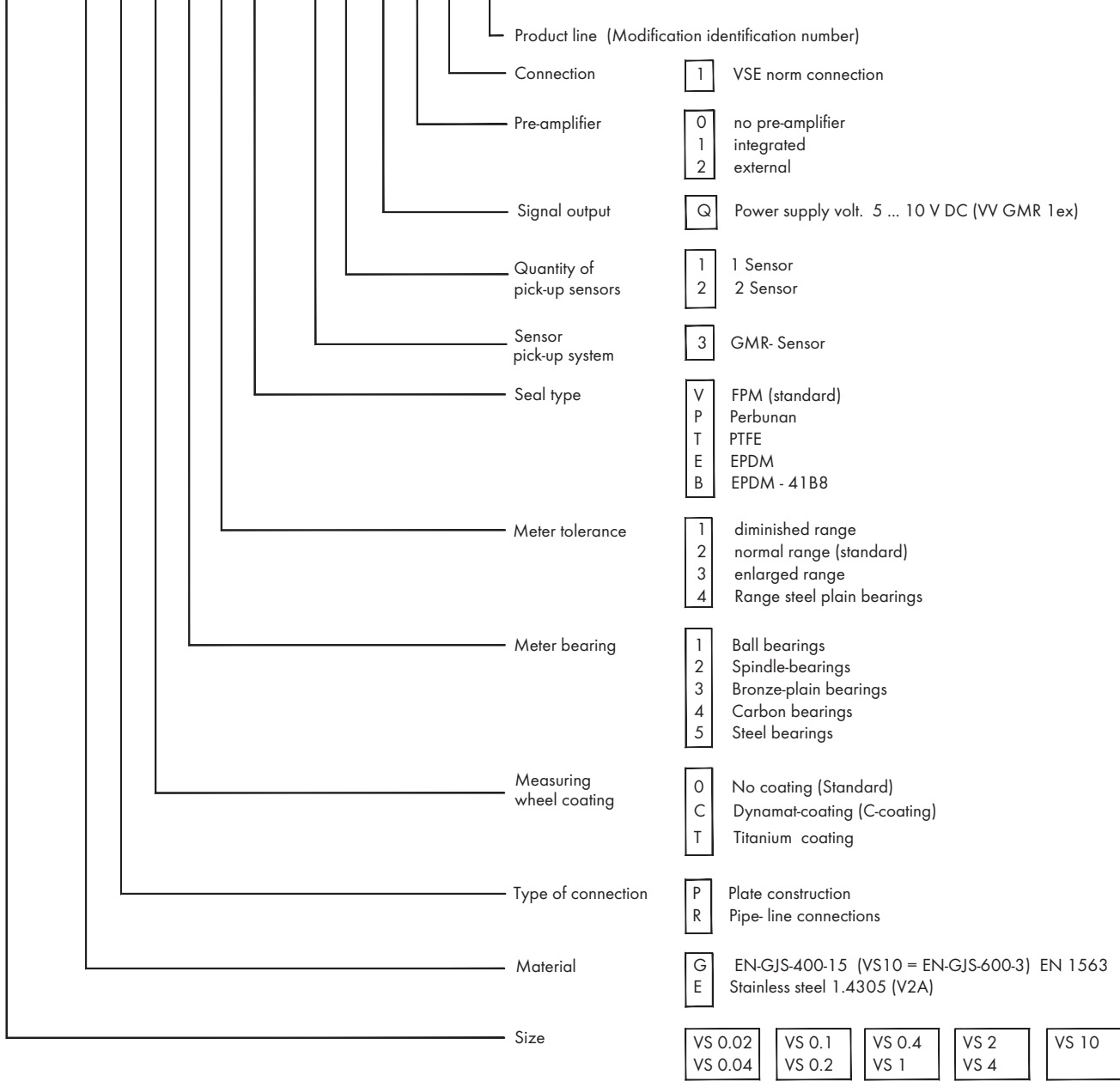

Subplates AP

Example:

**AP G 1 S C 0 N / 1**

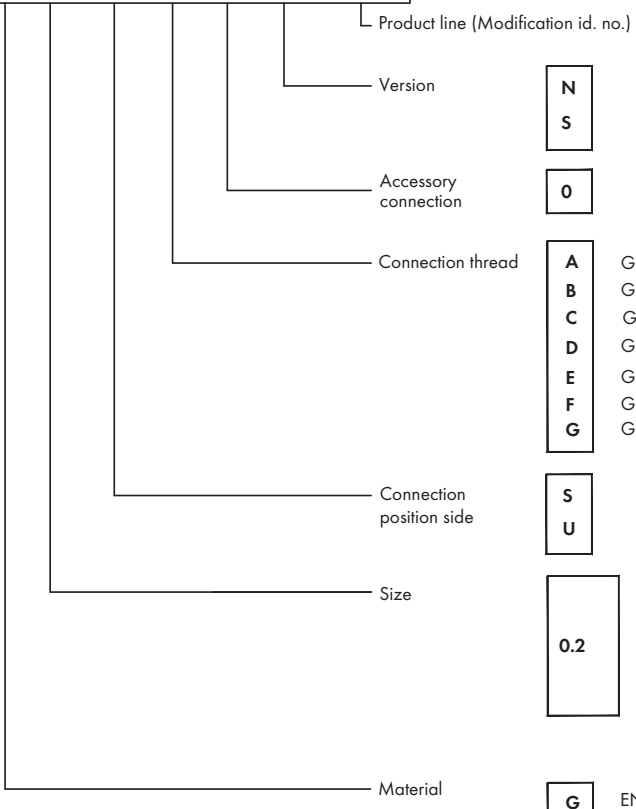

<b>N</b>	Standard version				
<b>S</b>	Special version				
<b>0</b>	without rinse connection				
<b>A</b>	G 1/4	<b>J</b>	1/4 NPT	<b>S</b>	SAE 1/2
<b>B</b>	G 3/8	<b>K</b>	3/8 NPT	<b>T</b>	SAE 3/4
<b>C</b>	G 1/2	<b>L</b>	1/2 NPT	<b>U</b>	SAE 1
<b>D</b>	G 3/4	<b>M</b>	3/4 NPT	<b>V</b>	SAE 1 1/4
<b>E</b>	G1	<b>N</b>	1 NPT	<b>W</b>	SAE 1 1/2
<b>F</b>	G1 1/4	<b>O</b>	1 1/4 NPT	<b>X</b>	SAE 2
<b>G</b>	G1 1/2	<b>P</b>	1 1/2 NPT		
<b>S</b>	Connection position side				
<b>U</b>	Connection below				
<b>0.2</b>	VS 0.02	<b>0.4</b>	VS 0,4		
	VS 0.04	<b>1</b>	VS 1		
	VS 0.1	<b>4</b>	VS 4		
	VS 0.2	<b>10</b>	VS10		
<b>G</b>	EN-GJL-250, EN-GJS-400-15 (DIN EN 1561/1563)				
<b>E</b>	Stainless steel 1.4305				

## LABELING OF THE FLOW METERS

Name and address of the manufacturer

VSE Volumentechnik GmbH  
Hönnestraße 49  
58809 Neuenrade / Germany

CE label



Type designation

VS \*\*\* \*\*\*\*\*-32Q1 \*/\*

Compliance with the ATEX-directive



Compliance with the NEC-directive



Type plates

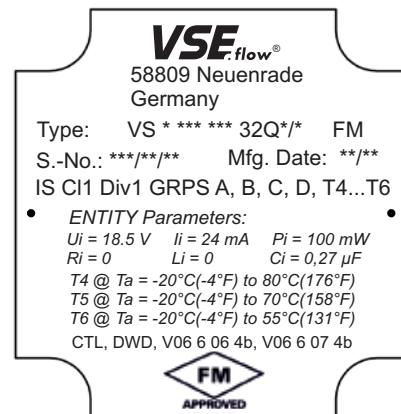
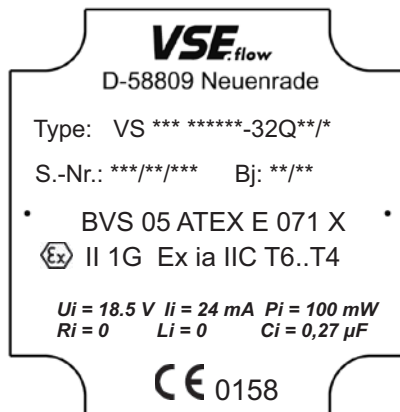

## SAFETY DATA FOR FLOW METER TYPE VS \*\*\* \*\*\*\*\*-32Q1 \*/\*

### Nominal values:

Nominal voltage  $V_{CC1,2} = 5 \dots 10 \text{ V}$   
Switching current  $I_{Low1,2} < 2.7 \text{ mA}$  ( $I_{Low\ min1,2} > 2.0 \text{ mA}$ )  
 $I_{High1,2} > 3.7 \text{ mA}$  ( $I_{high\ max1,2} < 4.5 \text{ mA}$ )

### Maximum values

$U_i = 18.5 \text{ V}$   $C_i = 0.27 \text{ µF}$   
 $I_i = 24 \text{ mA}$   $L_i = 0$   
 $P_i = 100 \text{ mW}$   $R_i = 0$





## MAXIMUM AMBIENT AND MEDIA TEMPERATURES

Temperature class	T4	T5	T6
<b>ATEX</b>	<b>T4</b>	<b>T5</b>	<b>T6</b>
Ambient temperature	$-20^{\circ}\text{C} (-4^{\circ}\text{F}) \leq T_{\text{amb}} \leq 95^{\circ}\text{C} (203^{\circ}\text{F})$	$-20^{\circ}\text{C} (-4^{\circ}\text{F}) \leq T_{\text{amb}} \leq 70^{\circ}\text{C} (158^{\circ}\text{F})$	$-20^{\circ}\text{C} (-4^{\circ}\text{F}) \leq T_{\text{amb}} \leq 55^{\circ}\text{C} (131^{\circ}\text{F})$
Media temperature	$-20^{\circ}\text{C} (-4^{\circ}\text{F}) \leq T_{\text{Med}} \leq 100^{\circ}\text{C} (212^{\circ}\text{F})$	$-20^{\circ}\text{C} (-4^{\circ}\text{F}) \leq T_{\text{Med}} \leq 75^{\circ}\text{C} (167^{\circ}\text{F})$	$-20^{\circ}\text{C} (-4^{\circ}\text{F}) \leq T_{\text{Med}} \leq 60^{\circ}\text{C} (140^{\circ}\text{F})$
<b>FM</b>	<b>T4</b>	<b>T5</b>	<b>T6</b>
Ambient / Media temperature	$-20^{\circ}\text{C} (-4^{\circ}\text{F}) \leq T_{\text{amb}} \leq 80^{\circ}\text{C} (176^{\circ}\text{F})$	$-20^{\circ}\text{C} (-4^{\circ}\text{F}) \leq T_{\text{amb}} \leq 70^{\circ}\text{C} (158^{\circ}\text{F})$	$-20^{\circ}\text{C} (-4^{\circ}\text{F}) \leq T_{\text{amb}} \leq 55^{\circ}\text{C} (131^{\circ}\text{F})$

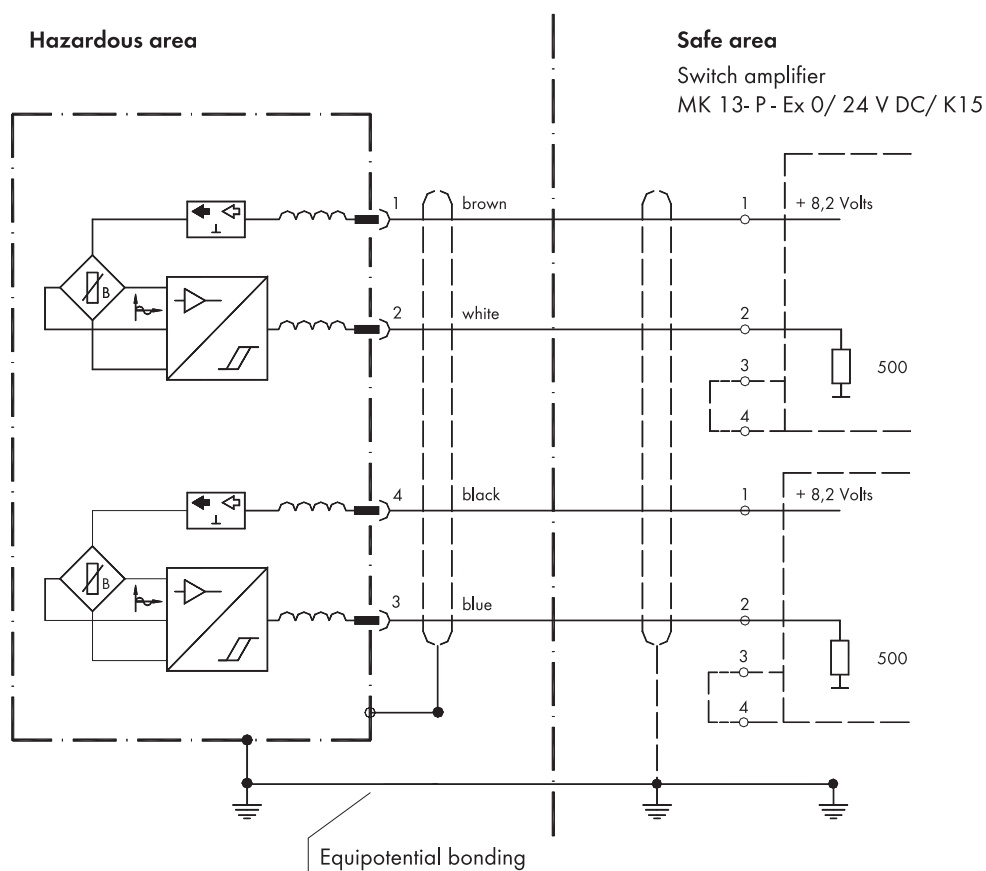
## PREAMPLIFIER-BLOCK WIRING DIAGRAM



## SUMMARY OF THE SAFETY-RELATED TECHNICAL DATA

Flow meter	VSE connecting cable, blue RAL 5015	Switching amplifier
Type: VS *** *****-32Q1*/*	shielded; 4 x 0.34 mm <sup>2</sup>	Type: MK13-P-Ex0/24 V DC/K15
BVS 05 ATEX E 071 X	PUR	Please refer to the seperately enclosed datasheet
FM-ID 302 6920		
 II 1G Ex ia IIC T4-T6		
 IS GL1 Div. 1 GRPS A, B, C, D, T4 ... T6		
$U_i = 18.5 \text{ V}$	$R = 0.053 \text{ } \Omega/\text{m}$	
$I_i = 24 \text{ mA}$	$L = 0.85 \text{ } \mu\text{H}/\text{m}$ (x)	
$P_i = 100 \text{ mW}$	$C_{A-A} = 55 \text{ pF}/\text{m}$ (x)	
$R_i = 0$	$C_{A-S} = 105 \text{ pF}/\text{m}$ (x)	
$L_i = 0$	[(x) = measured at 1000 Hz]	
$C_i = 0.27 \text{ } \mu\text{F}$		

Temperature class	T4	T5	T6
<b>ATEX</b>	<b>T4</b>	<b>T5</b>	<b>T6</b>
Ambient temperature	$-20^\circ\text{C} (-4^\circ\text{F}) \leq T_{\text{amb}} \leq 95^\circ\text{C} (203^\circ\text{F})$	$-20^\circ\text{C} (-4^\circ\text{F}) \leq T_{\text{amb}} \leq 70^\circ\text{C} (158^\circ\text{F})$	$-20^\circ\text{C} (-4^\circ\text{F}) \leq T_{\text{amb}} \leq 55^\circ\text{C} (131^\circ\text{F})$
Media temperature	$-20^\circ\text{C} (-4^\circ\text{F}) \leq T_{\text{Med}} \leq 100^\circ\text{C} (212^\circ\text{F})$	$-20^\circ\text{C} (-4^\circ\text{F}) \leq T_{\text{Med}} \leq 75^\circ\text{C} (167^\circ\text{F})$	$-20^\circ\text{C} (-4^\circ\text{F}) \leq T_{\text{Med}} \leq 60^\circ\text{C} (140^\circ\text{F})$
<b>FM</b>	<b>T4</b>	<b>T5</b>	<b>T6</b>
Ambient / Media temperature	$-20^\circ\text{C} (-4^\circ\text{F}) \leq T_{\text{amb}} \leq 80^\circ\text{C} (176^\circ\text{F})$	$-20^\circ\text{C} (-4^\circ\text{F}) \leq T_{\text{amb}} \leq 70^\circ\text{C} (158^\circ\text{F})$	$-20^\circ\text{C} (-4^\circ\text{F}) \leq T_{\text{amb}} \leq 55^\circ\text{C} (131^\circ\text{F})$



**Translation**

**EC-Type Examination Certificate**

(1)

(2)

**- Directive 94/9/EC -  
Equipment and protective systems intended for use  
in potentially explosive atmospheres**

(3)

**BVS 05 ATEX E 071 X**

(4)

**Equipment: Volume sensor type VS \*\*\* \*\*\*\*\*-32Q1\*/\*and Typ EF \*\*\* Q\*\*\*\*\*\_/\*\***

(5)

**Manufacturer: VSE Volumentechnik GmbH**

(6)

**Address: 58809 Neuenrade, Germany**

(7)

The design and construction of this equipment and any acceptable variation thereto are specified in the schedule to this type examination certificate.

(8)

The certification body of EXAM BBG Prüf- und Zertifizier GmbH, notified body no. 0158 in accordance with Article 9 of the Directive 94/9/EC of the European Parliament and the Council of 23 March 1994, certifies that this equipment has been found to comply with the Essential Health and Safety Requirements relating to the design and construction of equipment and protective systems intended for use in potentially explosive atmospheres, given in Annex II to the Directive.  
The examination and test results are recorded in the test and assessment report BVS PP 05.2049 EG.

(9)

The Essential Health and Safety Requirements are assured by compliance with:  
EN 50014:1997+A1-A2 General requirements  
EN 50020:2002 Intrinsic safety 'i'  
EN 50284:1999 Equipment Group II Category IG

(10)

If the sign "X" is placed after the certificate number, it indicates that the equipment is subject to special conditions for safe use specified in the schedule to this certificate.

(11)

This EC-Type Examination Certificate relates only to the design, examination and tests of the specified equipment in accordance to Directive 94/9/EC.  
Further requirements of the Directive apply to the manufacturing process and supply of this equipment. These are not covered by this certificate

(12)

The marking of the equipment shall include the following:

**II 1G EEx ia IIC T4 – T6**

**EXAM BBG Prüf- und Zertifizier GmbH**

Bochum, dated 11. May 2005

Signed: Dr. Jockers

Signed: Dr. Eickhoff

Certification body

Special services unit



(13) Appendix to

(14) **EC-Type Examination Certificate**

**BVS 05 ATEX E 071 X**

(15) 15.1 Subject and type

Volume sensor type VS \*\*\* \*\*\*\*\*-32Q1\*/\*\*and type EF \*\*\* Q\*\*\*\*\*\_\*/\*\*

Instead of the \*\*\* in the complete denomination letters and numerals will be inserted, which characterize modifications without influence on explosion protection.

15.2 Description

The volume sensor is used for measurement of flow or mass flow of liquids.

The electrical components of the sensor are mounted inside an aluminium (EF \*\*\* Q\*\*\*\*\*\_\*/\*\*) or a cast iron or stainless steel enclosure (Typ VS \*\*\* \*\*\*\*\*-32Q1\*/\*\*).

The electrical connection is done by a connector.

15.3 Parameters

each channel

Voltage	Ui	DC	18,5	V
Current	Ii		24	mA
Power	Pi		100	mW
Effective internal capacitance	Ci		0,27	µF
Effective internal inductance	Li		negligible	

The temperature class will be defined depending on the ambient temperature range and the medium temperature in accordance with the following table:

Temperature class	T4	T5	T6
Ambient temperature range	-20 °C up to 95 °C	-20 °C up to 70 °C	-20 °C up to 55 °C
max. medium temperature	100 °C	75 °C	60 °C

(16) Test and assessment report  
BVS PP 05.2049 EG as of 11.05.2005

(17) Special conditions for safe use  
The use of volume sensors type EF \*\*\* Q\*\*\*\*\*\_\*/\*\* in areas, where Category 1-equipment is necessary, the sensor has to be mounted in such a way that sparks by operational friction or impact are not possible.



---

We confirm the correctness of the translation from the German original.  
In the case of arbitration only the German wording shall be valid and binding.

44809 Bochum, 18.08.2005  
BVS-Schu/Mi A 20040708

**EXAM BBG Prüf- und Zertifizier GmbH**

---

Certification body

---

Special services unit



**Translation**

**1st Supplement**

(Supplement in accordance with Directive 94/9/EC Annex III number 6)

**to the EC-Type Examination Certificate  
BVS 05 ATEX E 071 X**

**Equipment:** Volume sensor type VS \*\*\* \*\*\*\*\*-32Q1\*/\* and type EF \*\*\* Q\*\*\*\*\*-\*/\*

**Manufacturer:** VSE Volumentchnik GmbH

**Address:** 58809 Neuenrade, Germany

Description

The sensor can be modified according to the descriptive documents as mentioned in the pertinent test and assessment report.

The Essential Health and Safety Requirements of the modified equipment are assured by compliance with:

- EN 50014:1997+A1-A2      General requirements
- EN 50020:2002          Intrinsic safety 'i'
- EN 50284:1999          Equipment Group II Category 1G

The marking of the equipment shall include the following:

 II 1G EEx ia IIC T4 – T6

Special conditions for safe use

The use of volume sensors type EF \*\*\* Q\*\*\*\*\*-\*/\* in areas, where Category I-equipment is necessary, the sensor has to be mounted in such a way that sparks by operational friction or impact are not possible.

Test and assessment report

BVS PP 05.2049 EG as of 31.05.2006

**EXAM BBG Prüf- und Zertifizier GmbH**  
Bochum, dated 31. May 2006

Signed: Dr. Jockers

Signed: Dr. Eickhoff

Certification body

Special services unit



We confirm the correctness of the translation from the German original.  
In the case of arbitration only the German wording shall be valid and binding.

44809 Bochum, 31. May 2006  
BVS-Schu/Kw A 20060265

**EXAM BBG Prüf- und Zertifizier GmbH**

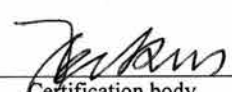
  
\_\_\_\_\_  
Certification body

  
\_\_\_\_\_  
Special services unit

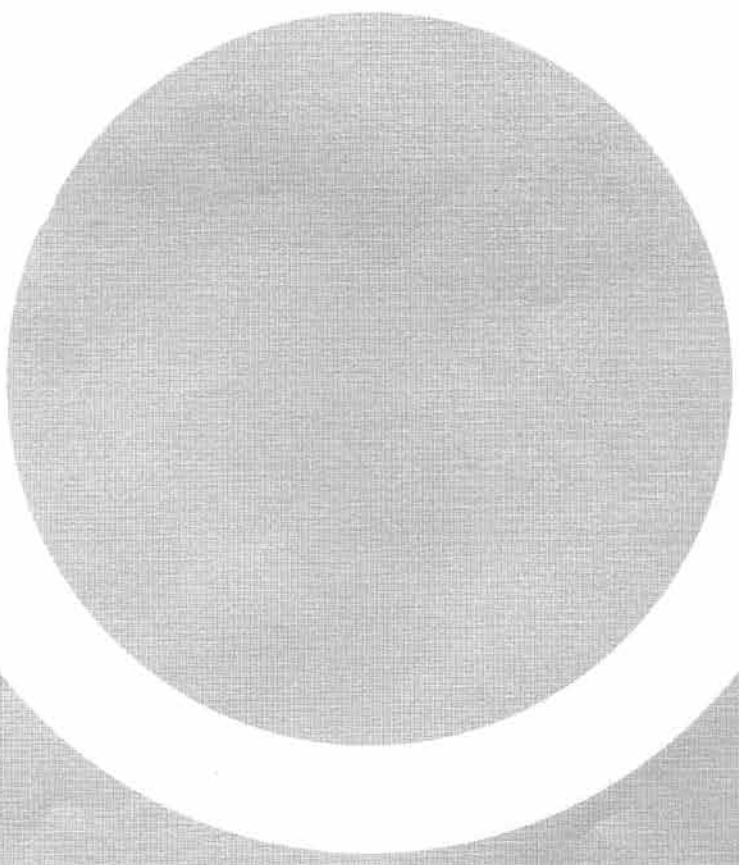



## 2nd Supplement

(Supplement in accordance with Directive 94/9/EC Annex III number 6)

### to the EC-Type Examination Certificate BVS 05 ATEX E 071 X

**Equipment:** Volume sensor type VS \*\*\* \*\*\*\*\*-32Q1\*\*/ and type EF \*\*\* Q\*\*\*\*\*\_\*\*/

**Manufacturer:** VSE Volumentechnik GmbH

**Address:** 58809 Neuenrade, Germany

#### Description

The flow sensor has been tested in acc. with EN 60079-\*\* and an additional version (with permanently connected cable) is possible.

The Essential Health and Safety Requirements of the modified equipment are assured by compliance with:

EN 60079-0:2006 General requirements  
 EN 60079-11:2007 Intrinsic safety 'i'  
 EN 60079-26:2004 Equipment Group II Category 1G

The marking of the equipment shall include the following:

**Ex II 1G Ex ia IIC T4-T6**

#### Parameters

each channel				
Voltage	Ui	DC	18.5	V
Current	Ii		24	mA
Power	Pi		100	mW
Effective internal capacitance	Ci		0.27	µF
Effective internal inductance	Li		negligible	

The temperature class will be defined depending on the ambient temperature range and the medium temperature in accordance with the following table:

Temperature class	T4	T5	T6
Ambient temperature range with connector	-20 °C up to +95 °C	-20 °C up to +70 °C	-20 °C up to +55 °C
Ambient temperature range with permanently connected cable	-40 °C up to +95 °C	-40 °C up to +70 °C	-40 °C up to +55 °C
max. medium temperature	100 °C	75 °C	60 °C

Page 1 of 2 to BVS 05 ATEX E 071 X / N2

This certificate may only be reproduced in its entirety and without change.

DEKRA EXAM GmbH Dinnendahlstrasse 9 44809 Bochum Germany Phone +49 234/3696-105 Fax +49 234/3696-110 E-mail zs-exam@dekra.com (until 31.03.2007 EXAM BBG Prüf- und Zertifizier GmbH)





Special conditions for safe use

The volume sensor has to be mounted in such a way that sparks by operational friction or impact are not possible.

Test and assessment report

BVS PP 05.2049 EG as of 29.07.2009

**DEKRA EXAM GmbH**

Bochum, dated 29. July 2009

Signed: Simanski

Certification body

Signed: Dr. Eickhoff

Special services unit

---

We confirm the correctness of the translation from the German original.  
In the case of arbitration only the German wording shall be valid and binding.

44809 Bochum, 29. July 2009  
BVS-Schu / Her A 20090571

**DEKRA EXAM GmbH**

Certification body

Special services unit



Member of the FM Global Group

FM Approvals  
 1151 Boston Providence Turnpike  
 P.O. Box 9102 Norwood, MA 02062 USA  
 T: 781 762 4300 F: 781-762-9375 www.fmapprovals.com

# CERTIFICATE OF COMPLIANCE

## HAZARDOUS (CLASSIFIED) LOCATION ELECTRICAL EQUIPMENT

This certificate is issued for the following equipment:

**Type VS\*\*\* a\*\*\*\*\*-32Q1\*/\* and Type EF \*\*\* Q\*\*\*\*\*-\*/\*. Volume Sensors**  
 IS/II/1/ABCD/T4 @ Ta = -20 °C – 80 °C (-4 °F – 176 °F); T5 @ Ta = -20 °C - 70°C (-4 °F – 158 °F); T6 @ Ta = -20 °C – 55 °C (-4 °F – 131 °F); Entity

Entity Parameters:

$V_{Max} = 18.5 \text{ V}$ ,  $I_{Max} = 24 \text{ mA}$ ,  $P_{Max} = 100 \text{ mW}$ ,  $C_i = 0.27 \text{ }\mu\text{F}$ ,  $L_i = 0 \text{ mH}$ .

a = Housing: E = 303 Stainless Steel (1.4305); G = Grey Cast Iron (GGG40).

The EF-Type consists of aluminum.

The preamplifier housing AK 061 consists of aluminum.

\* = Options not affecting safety, any single digit letter or number referring to non-electrical properties as product associates, language, delivery packing, documentation, etc.

Equipment Ratings:

Intrinsically Safe with Entity Parameters for Class I, Division 1, Groups A, B, C & D hazardous (classified) locations

FM Approved for:

VSE Volumentchnik GmbH  
 Neuenrade, Germany



This certifies that the equipment described has been found to comply with the following Approval Standards and other documents:

Class 3600	1998
Class 3610	2010
Class 3810	2005

Original Project ID: 3026920

Approval Granted: September 17, 2007

Subsequent Revision Reports / Date Approval Amended

Report Number	Date	Report Number	Date
3043197	September 26, 2011		

FM Approvals LLC

*J. E. Marquedant*  
 \_\_\_\_\_  
 J. E. Marquedant  
 Group Manager, Electrical

26 September 2011  
 \_\_\_\_\_  
 Date



## SAFETY DECLARATION FOR RETURN DELIVERIES (CERTIFICATE OF NON-OBJECTION)

Last revised: 10/2021

Please reply to [info@vse-flow.com](mailto:info@vse-flow.com)

Flow meters, for which this certificate of conformity has not been completed and signed, cannot be inspected or repaired for safety reasons and will be returned unchecked at your expense.

Article number	
Quantity	
Reason for return	

The flow meter was used in health/environmentally hazardous media.

 No

 Yes

The flow meter is free from residuals.

 No

 Yes

Special safety measures or treatment is necessary or expected.

 No

 Yes

The flow meter was last used with the following media:

If yes, which

	<input type="radio"/> No	<input type="radio"/> Yes*	
Solvents	<input type="radio"/> No	<input type="radio"/> Yes*	
Toxic liquids	<input type="radio"/> No	<input type="radio"/> Yes*	
Biologically active liquids	<input type="radio"/> No	<input type="radio"/> Yes*	
Radioactive liquids	<input type="radio"/> No	<input type="radio"/> Yes*	
Corrosive liquids	<input type="radio"/> No	<input type="radio"/> Yes*	
Alkali	<input type="radio"/> No	<input type="radio"/> Yes*	
Explosive liquids	<input type="radio"/> No	<input type="radio"/> Yes*	
Other media	<input type="radio"/> No	<input type="radio"/> Yes*	

\* Please add the safety data sheet for the medium in the appendix.



## SAFETY DECLARATION FOR RETURN DELIVERIES (CERTIFICATE OF NON-OBJECTION)

Please reply to [info@vse-flow.com](mailto:info@vse-flow.com)

The undersigned assures that the above information is correct and complete and the shipping is carried out according to legal regulations. The undersigned is liable for all damages which arise as a result of the non-marked decontamination of the returned flow meter.

VSE expressly points out that repairs and verification work is carried out by trusting the correctness of the completion of this safety declaration (certificate of non-objection). Should physical injuries, death or even damage to property occur, claims for damages will be asserted.

<b>Company</b>	
<b>Street / Building no.</b>	
<b>Postcode / Town</b>	
<b>Phone</b>	
<b>Fax</b>	
<b>Email</b>	

**Contact**  
(in capitals)

**Date**

**Signature**  
(company stamp)

**Enclosed**





**VSE**.flow®

VSE Volumentchnik GmbH  
Hönnestraße 49  
58809 Neuenrade / Germany

Phone +49 (0) 23 94 / 6 16-30

Fax +49 (0) 23 94 / 6 16-33

info@vse-flow.com

[www.vse-flow.com](http://www.vse-flow.com)

**e.holding**  
FLUID TECHNOLOGY GROUP

[www.e-holding.de](http://www.e-holding.de)