

Solutions for Fluid Technology

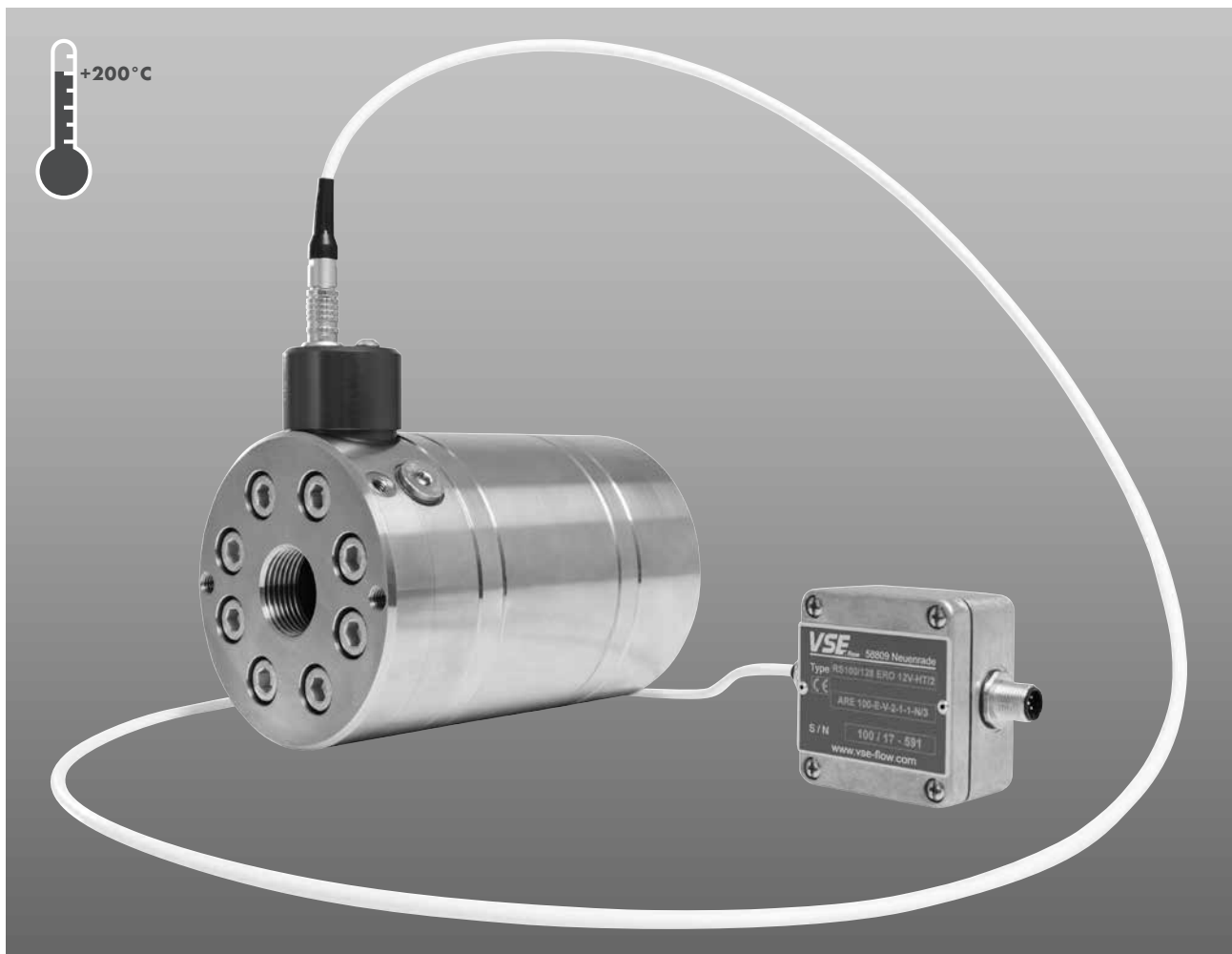

OPERATING MANUAL

for flow meters of the product line "RS High Temperature Version"

TABLE OF CONTENTS

	Page
1. Important information and legal notices	3
2. General function description of flow meter	4
3. General discription	4
4. RS flow meter selection	4
5. Declaration of conformity	4
6. General operating requirements.	5
7. Maximum operating pressure	6
8. Information on EU Directive 2014/68/EU on pressure equipment	6
9. Flow meter range	6
10. Assembly of the flow meter	6
11. Cleaning and flushing of pipe lines before initial start-up	7
12. Fluid filtering.	8
13. Function of the RS-HT-sensor electronics.	8
14. Flow diagrams vs. frequency.	10
15. Pulse filtering	13
16. Programming of the preamplifier.	14
17. Indicating LEDs.	14
18. Preamplifier technical data.	15
19. Plug assignment of separated preamplifier.	16
20. Maintenance, service life and warranty.	17
21. Storage, return and disposal	17
22. RS-HT flow meter technical data	17
23. Pressure/temperature limits.	18
24. RS-HT flow meter flow characteristics	19
25. RS-HT flow meter dimensions	21
26. Type key.	24
27. Plug assignment separated preamplifier	25
28. Connection diagram	25
29. Certificate of Non-Objection	26

The current publication of this operating instruction supersedes all information from previous publications. VSE reserves the right to make changes and substitutions. VSE is not liable for any printing errors. Reproduction, including excerpts, is permitted only after written approval by VSE. VSE reserves the right to modify technical data at any time.
Last revised: 02/2022



1. IMPORTANT INFORMATION AND LEGAL NOTICES

Dear customer, dear user,

This operating instruction for volume sensors of the “**RS High Temperature Version**” series by VSE Volumentchnik GmbH (VSE) contains information required to properly install and commission the flow meter for the intended purpose.

Any installation, commissioning, operation, maintenance and testing may only be carried out by trained and authorized personnel. The operating instructions must be read and followed carefully to ensure a trouble-free, proper and safe operation of the flow meter. In particular, the safety instructions are essential.

These operating instructions must be kept safe and accessible for the authorized personnel at all times. At no time should contents of the operating instructions be removed. A missing manual or missing pages must be replaced immediately if lost. The operating instructions can be requested at any time from VSE or downloaded from our website www.vse-flow.com. The operating instructions must be passed on to each subsequent user of the flow meter.

This operating instruction is not subject to any modification service by VSE. VSE reserves the right to make technical changes at any time without notice.

VSE makes no warranties, express or implied, with respect to commercial qualities and suitability for a particular purpose.

VSE accepts no liability for damage and malfunctions resulting from operating errors, failure to observe these operating instructions, improper installation, commissioning or maintenance as well as improper use of the flow meter.

The opening of the flow meter is absolutely not permitted. After an unauthorized opening or rebuilding as well as after a single, incorrect connection of the flow circuits of the flow meter, the warranty as well as the product liability by VSE expire.

2. FUNCTION DESCRIPTION OF THE RS-HT FLOW METER

RS flow meters measure the flow rate based on the screw pump principle. A pair of rotors fitted precisely into the housing constitutes the measuring element. An integrated magnetic pole wheel and a non-contact signal pick-up system detect the rotation of the measuring element and convert them to digital pulses.

Together with the housing walls, the rotor edges form closed measuring chambers in which the fluid is transported from the inlet to the outlet side. The fluid volume put through within one main rotor rotation is the rotation volume, which is divided by the sensing gear and digitised, processed and output in the sensor module.

Explanation of the sensor system RS high-temperature version (HT)

The non-contact pick-up system consists of two AMR bridges (sin/cos), which are located in a sensor unit in a cartridge housing that is specially designed for high temperatures. It detects the movement of the magnetic pole wheel and routes the sin/cos signals to the separated preamplifier electronics.

The preamplifier electronics digitise and amplify the sensor signals and multiply them by a high-resolution interpolator using adjustable settings. The square wave signals are bidirectional and can be utilised by any evaluating instrument as well as computers and PLC controls. The resolution is selectable in steps from factor 1 to 128. In case of a 1-channel evaluation, a separate directional signal is available.

Advantages

- High degree of precision that is mostly independent of viscosity
- Pulsation-free measurement
- Lowest pressure losses
- Short response time due to innovative rotor profile and reduced mass
- Highest functionality due to intelligent sensor technology
- Resistant to high and low temperatures
- Gentle fluid measurements

A selectable pulse filter can offset and suppresses negative flows (e.g. generated by vibrations) while still in the device.

The frequency of the output signals is proportional to the flow (volume flow) and depends on the respective flow meter size. The frequency range is from 0 to 100 kHz. The pick-up system is suitable for media temperatures of -40°C / -40°F to +200°C / 392°F (short-term peak of 220°C / 428°F).

The preamplifier is connected to the flow meter by a cable with a special plug connector. It is necessary to keep the preamplifier separated from high temperature and / or low temperature applications. The preamplifier electronics are protected against reverse polarity and incorrect connection.

3. GENERAL DESCRIPTION

Please follow all instructions in this manual to ensure the trouble-free operation of the RS flow meters in high-temperature version. VSE does not assume responsibility or liability for damages resulting from noncompliance

with these instructions. The device may only be opened within the warranty period after consultation and approval by VSE.

4. RS FLOW METER SELECTION

For the trouble-free, safe, and reliable operation of the flow meters, selecting the correct type and size is critical. Certain properties of the devices are dependent on type, size and measuring range, as well as the liquid

to be measured. Please contact VSE or one of our sales and service representatives for detailed information about the appropriate flow meter for your particular application.

5. DECLARATION OF CONFORMITY

Flow meters of the series "RS high-temperature version" have been tested for their electromagnetic compatibility and interference emissions as outlined by the EMC Directive and are in compliance with the applicable statutory EMC Directives.

They cannot be operated independently, are connected by cable to a power source, and provide digital electrical signals for electronic evaluation. All flow meters have a declaration of conformity, which can be requested if necessary.

Since the electromagnetic compatibility of the entire measuring system is also dependent on the installation of the cables, the correct connection of the shield, and each individual connected device, all components must comply with the EMC Directive, and the electromagnetic compatibility of the entire system, machine, or system must be ensured as well.

All flow meters have been tested in accordance with the applicable statutory EMC Directives and are CE certified. The EC conformity marking is the CE mark affixed to all flow meters.

6. GENERAL OPERATING REQUIREMENTS

Before assembly or putting into operation (commissioning), check and verify the following properties and aspects of the respective circumstances of your system to ensure operation is trouble-free, safe, and reliable.

1. The fluid to be processed

- Is the flow meter **suitable for the fluid**?
- Is the fluid **viscous** or **abrasive**?
- Is the fluid **dirty** or does it **contain contaminants/pollutants** and **solid particles**?
- Which **grain sizes** do these solids have and could they **block the measuring** element?
- Does the fluid have **fillers** or other **additives**?
- Is it necessary to install an upstream **hydraulic filter**?
- Are **tubes and pipes clean** and free of assembly residues such as chips, weld spatter?
- Is the **tank clean** and is it impossible for impurities or **foreign substances** to reach the pipeline or tubing system from the tank?
- Is a different fluid used frequently and is the system sufficiently flushed and **rinsed** in between?
- Are pipelines/tubes and the entire system completely **deaerated**?
- Which **cleaning agent** is being used?
- Are fluid and cleaning agent compatible with the **seals**?

2. Hydraulic properties of the system

- Is the **max. operating pressure** of the system less than the max. permissible operating pressure of the flow meter?
- Is the **max. pressure drop Δp** (at flow meter) below the max. permissible pressure drop?
- Is the **pressure drop Δp** not excessive with max. flow (e.g. high viscosity)?
- Does the flow range of the flow meter (dependent on the viscosity) correspond with the **present flow**?
- Please note that the flow range is less with **higher viscosity**!
- Does the temperature range of the flow meter correspond with **the present max. temperature** of the fluid?
- Is the **cross-section** of the pipelines/tubes large enough and are there no overly large pressure drops in the system?
- Is the **hydraulic connection** (inlet/outlet) connected corrected and sealed properly?
- Does the **pump** have enough power to operate the system?
- A blocked flow meter can stop the entire flow. Does the system feature an **overpressure/bypass** valve? This valve must be checked and maintained at regular intervals.

3. Electronic evaluation and electrical safety

- Have you selected the optimal flow meter and is this equipped with the **appropriate preamplifier**?
- Is the flow meter used in a high- or low-temperature application? Is the preamplifier **spatially separated** from the heated or cooled flow meter?
- Is the **fluidity** of the media **sufficient**? Is it necessary to **heat** the flow meter with a ring heater?
- Is the **separated preamplifier** connected correctly to the pick-up system of the flow meter?
- Does the **supply voltage** of the flow meter match the available power supply?
- Is the supply voltage to the power supply adapter or the evaluating device sufficiently **filtered**?
- Does the **output** of the supply voltage correspond with the required output?
- Is the electrical connection established based on the enclosed **wiring plan**?
- Is the **connection cable** protected by a shield?
- Is a **connection** of the cable shielding installed via the housing of the round pin plug to the flow meter?
- Is the flow meter connected firmly to the **earth conductor PE** or is the cable protective shield connected to ground GND?
- Are the connection cable and the connecting cable of the separated preamplifier laid interference-free and is the installation secured from input of **interference pulses**?
- Is the **round plug** of the connection cable firmly screwed together with the plug of the flow meter?
- Are the wires on the **evaluation device** correctly and properly connected?
- Is there a **potential difference** between the earth conductor PE on the flow meter and the earth conductor PE on the evaluation device?
- Does a correcting lead have to be laid to eliminate the **potential difference** between the flow meter and the evaluation device?
- Does the entire system correspond to the directives of the electromagnetic compatibility laws (**EMC**)?
- Have all local valid regulations, **applicable directives**, guidelines and background conditions of the **electromagnetic compatibility laws** been maintained and observed?
- Systems that can lead to personal injury through malfunction or failure are to be equipped with the **appropriate safety devices**. The functioning of these safety devices is to be checked at regular intervals!

7. MAXIMUM OPERATING PRESSURE

Before installing the flow meter, you must check whether the max. operating pressure of the system does not exceed the max. permissible operating pressure of the flow meter. The operating limits regarding pressure and temperature are explicitly specified in chapter 23 „Pressure / Temperature Limits“ and must be observed. Please observe that peak pressures may occur when operating the system.

In addition it is very important to choose the correct sealing material for your particular application.

Please consult VSE for the correct seals.

Important:

It is very important to use the correct sealing material for your particular application. This must be observed especially for application temperatures outside the range of -20°C / -4°F ... 120°C / 248°F. Please always consult VSE for the correct seals.



8. INFORMATION ON EU DIRECTIVE 2014/68/EU ON PRESSURE EQUIPMENT

In terms of Article 2, No. 5 of the directive named above, VSE volume sensors are so-called „pressuremaintaining components“ and this directive thereby relates to them. VSE volume sensors must thereby comply with the technical requirements named in Section 4 of the directive in accordance with Article 4, Paragraph (1d), Piping according to Paragraph (1c). Typically, the fluids measured fall into Group 2 in accordance with Article 13, Paragraph (1b). The volume sensors sold by VSE do not comply with the limit values defined under Article 4, Paragraph

(1a). The technical requirements on volume sensors from VSE are therefore limited to the criteria defined in Article 4, Paragraph (3). That means that the devices must be designed and manufactured in accordance with the good engineering practices prevailing in the member state. We hereby confirm this. The paragraph also states that these units may not bear the CE label named in Article 18. A CE declaration of conformity is therefore not issued in accordance with 2014/68/EU. The CE label of our volume sensors refers to Directive 2014/30/EU.

9. FLOW RATE MEASURING RANGE

The flow rate measuring range specified in the data sheet (Q_{min} – Q_{max}) of the flow meter refers to the test fluid „hydraulic oil“ with a viscosity of 21 mm²/s at a temperature of 20°C. For this measuring range, VSE specifies accuracy up to 0.3% of the measured value and a repeatability of 0.05%.

In fluids with low viscosity (< 21 mm²/s), the measurement accuracy degrades while it may improve with fluid with a high viscosity (> 21 mm²/s). Note also that the flow measuring range is limited at higher viscosity (see „RS flow meter technical data“).

Important:

Verify that the specified maximum permissible operating pressure of the flow meter can never be exceeded in any operating mode of the system. Also pay attention to the flow measuring range, which is dependent on the viscosity of the fluid to be measured.



10. MOUNTING THE FLOW METER

The flow meter should be mounted in an easily accessible location so that disassembly to clean the measuring elements is easy. Since flow meters operate in any installation position and flow direction, you can mount it anywhere in your system. When installing the flow meter, make sure that liquid remains in the flow meter even at standstill of the system and that the flow meter can never run dry. The outlet of the flow meter should always have a certain backpressure since this fixes the measuring element of the flow meter in the liquid column and the pipeline cannot empty itself (the measuring element uses to support itself on the liquid column). In critical cases, or if the pipeline can run empty in standstill or standby mode, it is always advisable to install an additional non-return check valve in the outlet line.

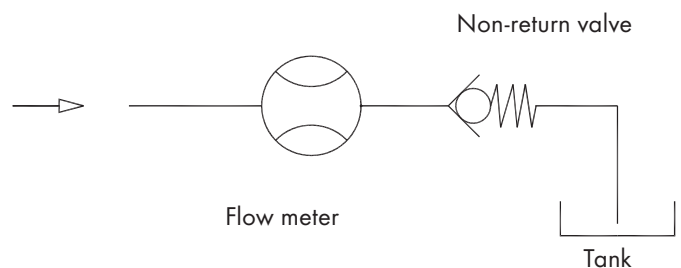

Fig. 1: Flow meter with backpressure

Important:

Make sure that the flow meter measuring elements are always completely filled both in inlet and outlet and that the outlet has a little backpressure. This prevents the measuring elements from being damaged by a sudden and steep increase of flow and at the same time improves measurement accuracy.



Flow meters of the „RS“ series can be installed in the pipeline. Always select large cross-sections (if possible) for the hydraulic inlet and outlet or the entire pipeline system. This reduces the pressure drop and the flow rate throughout the system.

INSTALLATION NOTES**Installation Position**

Any, note arrow indicating preferred direction if necessary (calibration arrow). Mount the separated preamplifier away from any potential heating or cooling source.

Straight pipe sections are **not** required in inlet/outlet.

Connecting Units

If the connecting units (mounting flanges) are to be installed on-site, compliance with the specified torque is required.

Pipe Thread

Please comply with the screw-in depths and sealing systems. Teflon tape or liquid sealants such as adhesives are not permitted!

Fastening

The devices must be installed stress-free into the pipeline. This is accomplished with fastening screws located at the face sides in the connecting units. For stress-free assembly, the compressive strength may be limited!

Table 1: Starting torque of the connection units

RS-Flow Meter Size	Torque
RS 25	in preparation
RS 40	35 Nm
RS 100	70 Nm
RS 400	120 Nm
RS 800	280 Nm
RS 2500	180 Nm

11. CLEANING AND FLUSHING OF PIPELINE BEFORE INITIAL START-UP

Before initial start-up of the flow meter, you must flush and clean the whole system to prevent contaminants from reaching the measuring elements during the assembly and installation. Foreign matter or contaminants may block the flow meter or severely damage it so that the flow meter readings are no longer valid and the device must be returned for repairs. After completion of the installation or piping, you must first flush the entire pipeline system and carefully clean and flush the tank. This requires that the flow meter is removed from the fluid circuit to flush out all foreign matter or contaminants (e.g. chips, metal parts) without problems. Use a rinsing fluid that is compatible with the subsequent used fluid and will not cause adverse reactions.

Such information can be obtained from the supplier or manufacturer of the fluid or from VSE.

Flow meters are sensors manufactured with a high degree of precision. They have mechanical measuring elements consisting of two rotors fitted into the housing with narrow gaps. Even the smallest damage to the rotors causes a measuring error. Always make sure that foreign matter or contaminants cannot reach the measuring elements and that the fluid flowing through the flow meter is always free of pollutants and particles. Once the system is thoroughly flushed and no extraneous material is in the piping system, you can mount the flow meter into the fluid circuit and start the actual initial startup process.

Important:

Please flush out the pipe lines and the tank thoroughly, to prevent contamination within the flow meter.



12. FLUID FILTERING

Heavily contaminated fluids or foreign matter in the fluid can block, damage, and even destroy the flow meter. In these cases, always install a sufficiently large filter in front of the flow meter so that foreign

particles and solids are prevented from entering the measuring elements, thus preventing damage to the flow meter. The required filtering depends on the size, bearing, and design of the flow meter.

Table 2: Pre-switched Filter

Flow meter size	Filter size for ball bearings
RS 25	in preparation
RS 40	100 µm
RS 100	250 µm
RS 400	250 µm
RS 800	500 µm
RS 2500	500 µm

The filter size for flow meters with slide bearings, in special designs, or with specially adapted measuring element tolerances can be obtained from VSE GmbH upon request.

Important:

A blocked flow meter is capable of stopping the entire flow. An overpressure / bypass valve must be installed in the system side.



13. FUNCTION OF THE RS-HT-SENSOR ELECTRONICS

The liquid to be measured flows through the rotor chambers in axial direction, resulting in an even rotation of the screw spindles.

This is done especially gentle and with very low resistance for the fluid to be measured as well as pulsation-free and almost free of leaks due to the specially designed fluidic profile geometry.

A magnetic pole wheel permanently fixed to the rotors is scanned without contact by a sensor module.

The non-contact pick-up system is specially designed for the high-temperature range. It consists of two AMR bridges (sin/cos), which are located in a sensor unit in cartridge design. It detects every movement of the sensing gear and routes the sin/cos signals to the separated pre-amplifier electronics. The preamplifier electronics digitise and amplify the sensor signals and multiply them by a high-resolution interpolator using adjustable settings. The square wave signals phase-shifted by 90° are bidirectional and can be utilised by any evaluating device as well as computers and PLC controls.

The flow is proportional to the edges/pulse count and the flow rate is proportional to the frequency. The adjustable interpolator can be used to adjust the resolution explicitly to the downstream connected evaluating unit for obtaining highly precise measuring results of the entire system. This applies to the following application cases, for example:

- Measuring, controlling, and regulating high viscosity fluids
- Measuring, controlling, and regulating in lower flow ranges
- Measuring, controlling, and regulating when passing through zero
- Measuring, controlling, and regulating in both flow directions
- Measuring, controlling, metering, and filling of small volumes

The resolution is selectable in steps from factor 1 to 128. The frequency range is from 0 to 100 kHz.

In case of a 1-channel evaluation, a separate directional signal is available.

The preamplifier unit is connected to the high-temperature resistance pick-up system of the flow meter by a teflon cable with a push-pull-connector. This conception enables the operation in a wide temperature range of -40°C / -40°F to +200°C / 392°F (short-term peak of 220°C / 428°F). The standard cable with a length of 1.5m allows to place the preamplifier away from the heating or cooling source. For example the measurement system can be used in climatic chambers or near combustion chambers.

Other cable length up to 3m are available on request.

The separated preamplifier is protected against reverse polarity and incorrect connection.

The fluid volume passed through by one gear division of the sensing wheel within the measuring element is divided by the set interpolation factor. This forms the measurement volume per pulse (V_m) with the defined unit [cm^3/pulse]. The frequency of the output signals can be calculated as follows:

$$f = \frac{Q}{V_m} \times \frac{1000}{60}$$

Formula 1: Calculation of the output frequency with Q in l/min

Table 3, Formula 2, and the subsequent diagrams can be used to determine the corresponding resolution or the corresponding IPF for the respective application.

Adjustable interpolation factors IPF: 1, 2, 5, 10, 25, 32, 50, 64, 100, 128

Table 3: Measurement volumes and K-factors

RS 25 – HT			
Interpolation factor (IPF)	Measurement volume V _m [cm ³ /Imp]	K-Factor [Imp/l]	K-Factor [Imp/gal.]
in preparation			

RS 100 – HT			
Interpolation factor (IPF)	Measurement volume V _m [cm ³ /Imp]	K-Factor [Imp/l]	K-Factor [Imp/gal.]
1	0.5866	1705	6454
2	0.2933	3409	12904
5	0.1173	8524	32267
10	0.0587	17047	64530
25	0.0235	42618	161327
32	0.0183	54552	206502
50	0.0117	85237	322657
64	0.0092	109103	413000
100	0.0059	170474	645314
128	0.0046	218207	826004

RS 800 – HT			
Interpolation factor (IPF)	Measurement volume V _m [cm ³ /Imp]	K-Factor [Imp/l]	K-Factor [Imp/gal.]
1	10.3846	96	363
2	5.1923	193	731
5	2.0769	481	1821
10	1.0385	963	3645
25	0.4154	2407	9111
32	0.3245	3081	11663
50	0.2077	4815	18227
64	0.1623	6163	23329
100	0.1038	9630	36454
128	0.0811	12326	46659

RS 40 – HT			
Interpolation factor (IPF)	Measurement volume V _m [cm ³ /Imp]	K-Factor [Imp/l]	K-Factor [Imp/gal.]
1	0.3219	3107	11761
2	0.161	6213	23519
5	0.0644	15533	58799
10	0.0322	31066	117598
25	0.0129	77664	293990
32	0.0101	99410	376308
50	0.0064	155328	587981
64	0.005	198820	752616
100	0.0032	310655	1175957
128	0.0025	397639	1505228

RS 400 – HT			
Interpolation factor (IPF)	Measurement volume V _m [cm ³ /Imp]	K-Factor [Imp/l]	K-Factor [Imp/gal.]
1	3.2587	307	1162
2	1.6294	614	2324
5	0.6517	1534	5807
10	0.3259	3069	11617
25	0.1303	7672	29042
32	0.1018	9820	37173
50	0.0652	15344	58083
64	0.0509	19640	74346
100	0.0326	30687	116163
128	0.0255	39279	148687

RS 2500 – HT			
Interpolation factor (IPF)	Measurement volume V _m [cm ³ /Imp]	K-Factor [Imp/l]	K-Factor [Imp/gal.]
1	38.4231	26	98
2	19.2116	52	197
5	7.6846	130	492
10	3.8423	260	984
25	1.5369	651	2464
32	1.2007	833	3153
50	0.7685	1301	4925
64	0.6004	1666	6306
100	0.3842	2603	9853
128	0.3002	3331	12609

Formula 2: Calculating the max. IPF

$$IPF \approx \frac{f_{\max} \times V_{mIPF1} \times 60}{Q_{\max} \times 1000}$$

The set IPF may not be larger than the calculated IPF!

- IPF Interpolationsfaktor
 f_{\max} Max. verarbeitbare Eingangsfrequenz
 V_{mIPF1} Messvolumen bei IPF=1
 (Volumen einer Zahnstruktur des Abtastrades)
 Q_{\max} Max. Betriebsdurchfluss in l/min

14. FLOW DIAGRAMS VS. FREQUENCY

RS 25 – HT

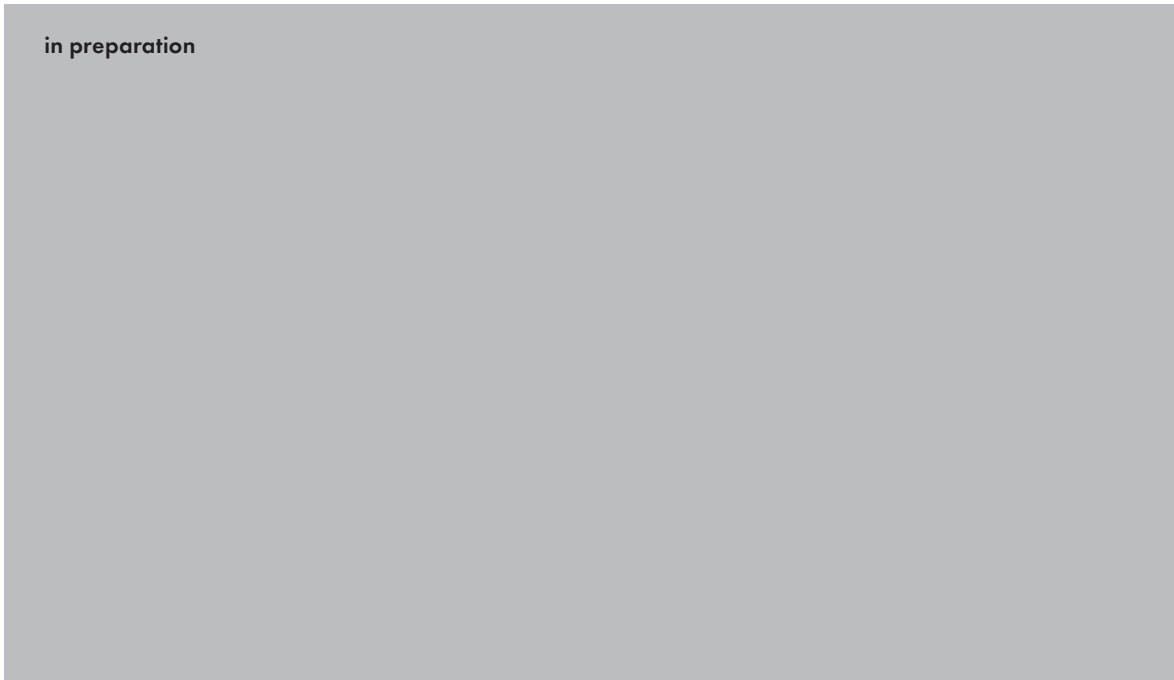

RS 40 – HT

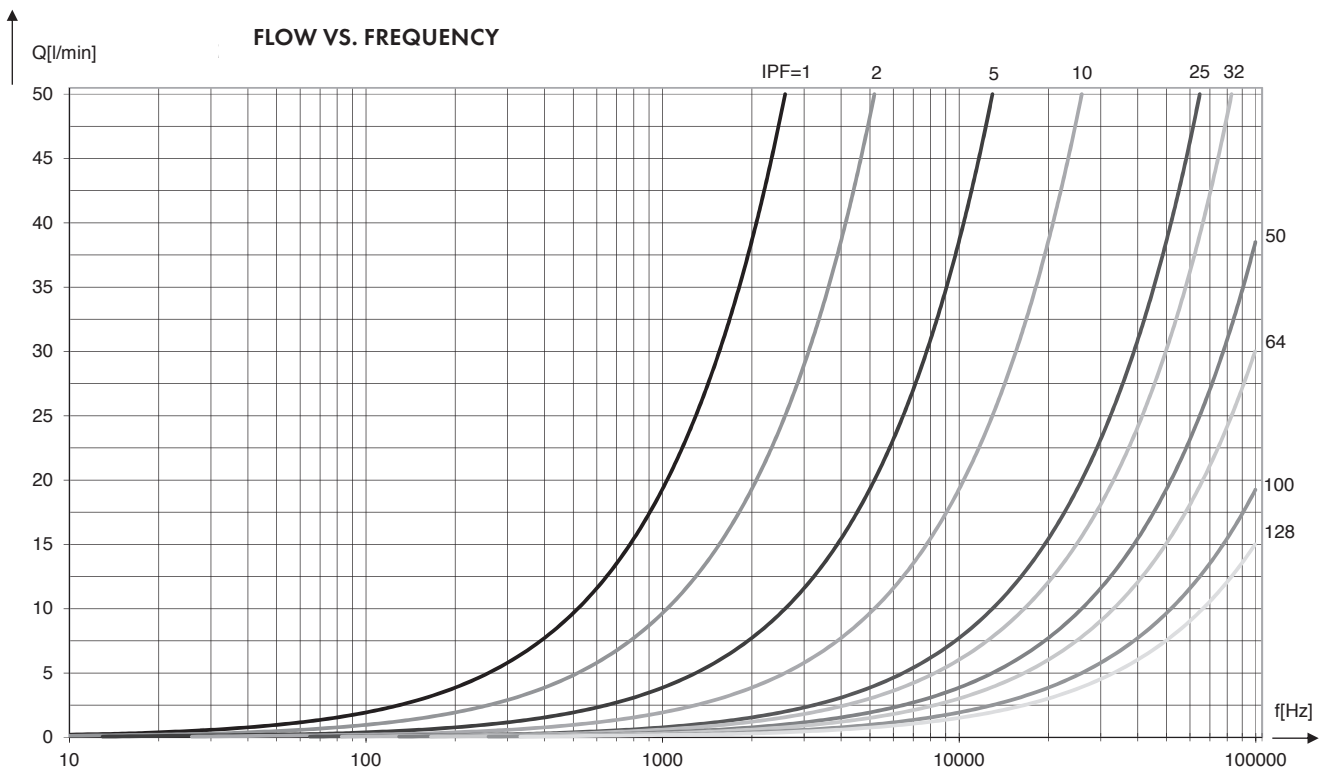

RS 800 - HT

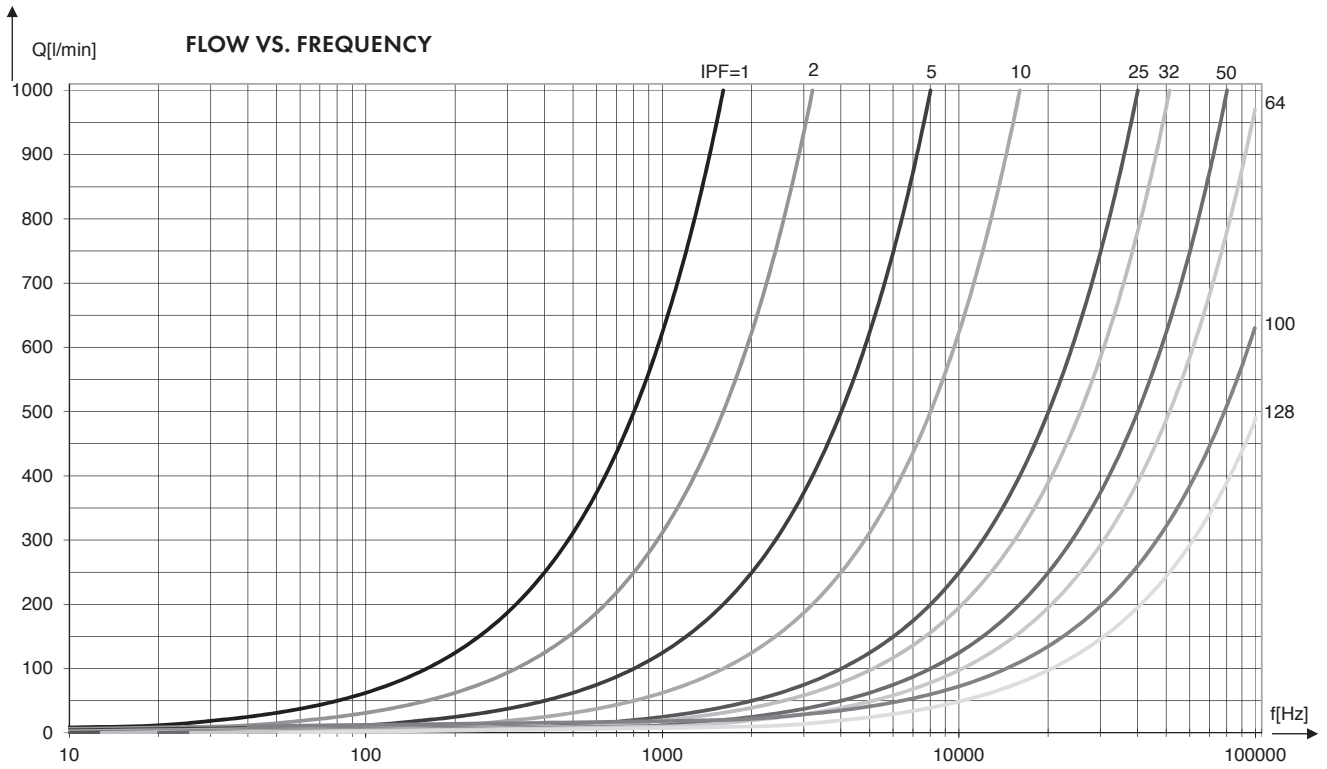

RS 2500 - HT

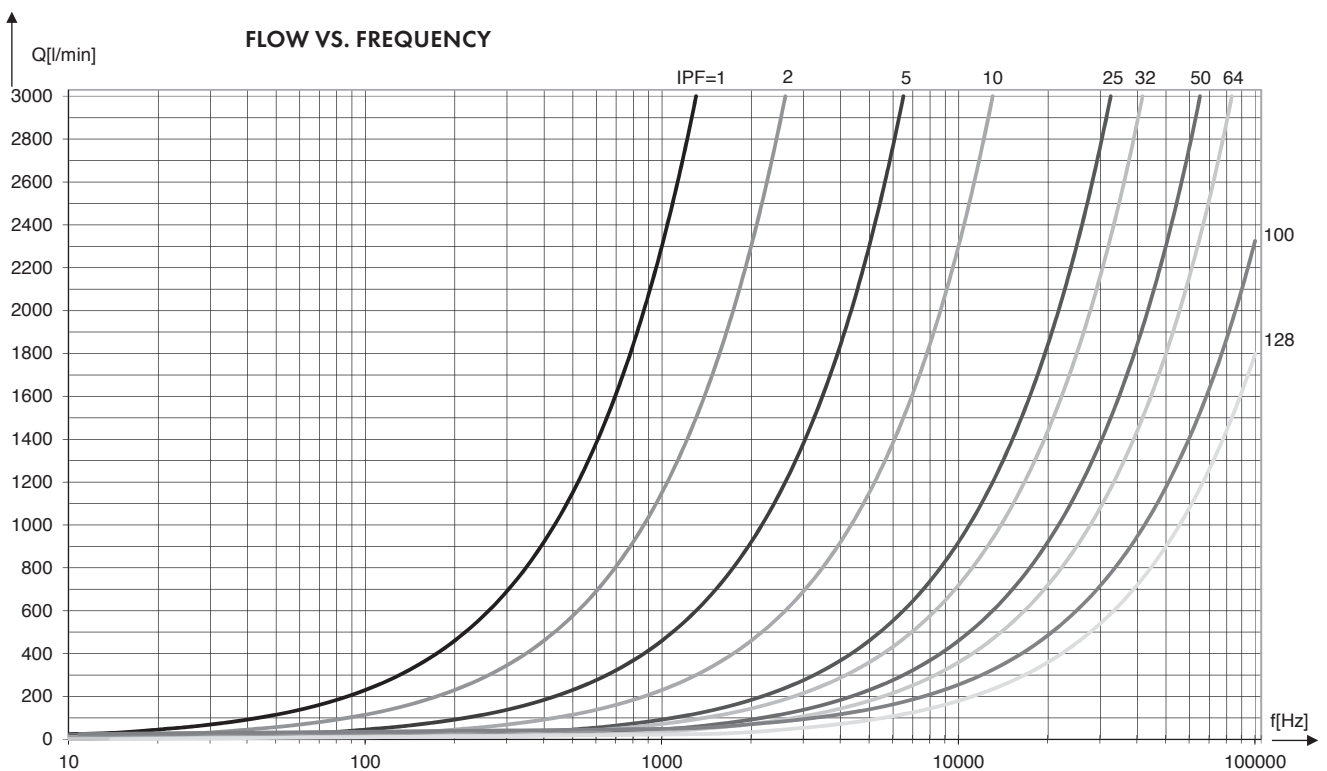

Example

Flow meter: RS 400 - HT

Max. processable input frequency of the downstream evaluating unit: 20 kHz

Max. operating flow: 140 l/min

Path 1: The diagram yields an IPF of 25

$$\text{Path 2: } \text{IPF} \approx \frac{f_{\max} \times V_{\text{mIPF1}} \times 60}{Q_{\max} \times 1000} = \frac{20.000 \frac{1}{\text{s}} \times 3,259}{140} \times \frac{60 \text{ s}}{1000 \text{ ml}} = 27,9 \approx 25$$

15. PULSE FILTERING

Oscillations in fluid systems manifest themselves through constant forward and backward movements of the liquid column, which is also detected by the rotor sensors and converted into proportional electronic pulses or edge sequences. Depending on the application, oscillations or vibrations can occur during the flow rest phases or discontinuous flows. The pulses generated during the oscillation phase can be incorrectly interpreted by the downstream evaluating unit or controller, which can be very distracting for the respective operating process.

The signal filtering function of the internal electronics continuously offsets these generated edges during the rapid forward and backward movements of the rotor measuring unit.

The user can enable or disable the filtering by changing the position of the jumper (B2).

During the filtering process, the pulses are calculated within a half turn of the magnetic pole wheel.

If a half turn is exceeded, the pulses will be available with the corresponding direction at the outputs. This direction will also be stored as the preferred flow direction.

The maximum suppressed volumes of the different flow meter sizes are listed in table 4.

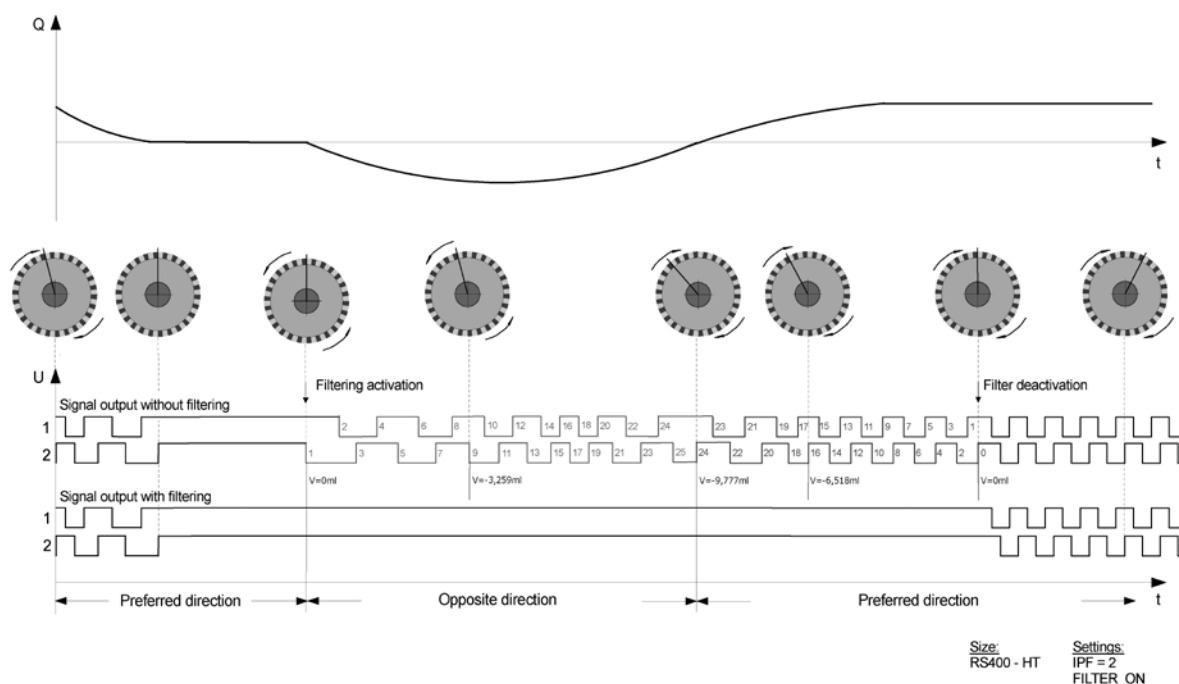

Fig. 3: Pulse filtering principle

Table 4: Maximum suppressed volume with pulse filtering activation [ml]

RS-HT flow meter size	max. suppressed volume
RS 25 - HT	in preparation
RS 40 - HT	4.19
RS 100 - HT	7.63
RS 400 - HT	42.36
RS 800 - HT	135
RS 2500 - HT	499.5

16. PROGRAMMING OF THE PREAMPLIFIER

All functions of the electronics can be set easily and quickly. A rotary coding switch (S4), a push button (S1) and two switches (S2, S3) are

located on the electronics board. The interpolation factor is set by the rotary coding switch.

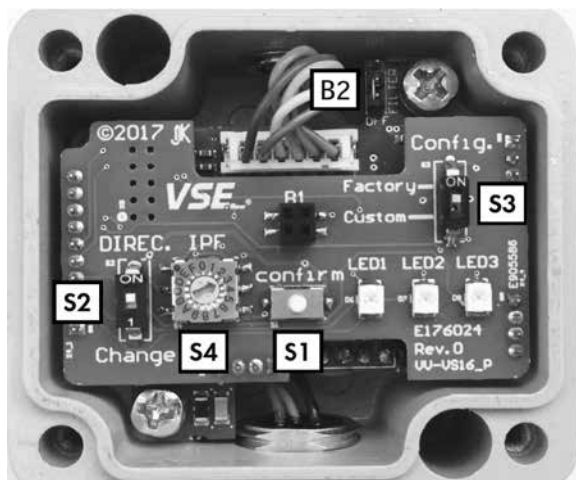

Fig. 4: Preamplifier peripheral board

With an already mounted flow meter it is possible to reserve the direction of the dual channel signals easily by switching (S2). Additionally the polarity of the separate direction signal on pin 5 is changed.

The pulse filtering can be enabled or disabled by changing the position of the jumper (B2).

In order for activating the flow meter you only need to set the desired interpolation factor with the rotary coding switch (S4), according to table 5. For this turn the rotary coding switch with a small screwdriver to the corresponding direction. The chosen factor is switched directly and is available at the output.

The IPF-setting can be modified at any time during operation.

Table 5: Interpolation factors

Switch position S4	Interpolation factor
0	1
1	2
2	5
3	10
4	25
5	32
6	50
7	64
8	100
9	128
A-F	no function

Important:

Take ESD preventive measures to prevent electrostatic discharge while working on the preamplifier electronics.



17. INDICATING LEDs

The LEDs of the electronics give information about the corresponding state. This includes certain operating and error conditions (see table 6 and 7).

The different states of the three LEDs indicate the corresponding condition.

These are either operating, warning or alarm messages. Operating messages signal the current setting (see. table 6). Warning and alarm-messages give exact information about overload, component faults of the system and factors which might negatively influence the measurement (see. table 7).

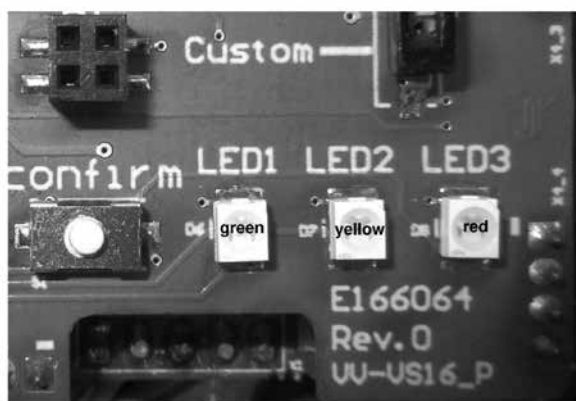

Fig. 5: Indicating LEDs of the peripheral board

Table 6: Operating messages

Mode	LED yellow	LED green	LED red
Normal operation	off	on	off
No IPF selected	off	flash	off

An active pulse output is indicated by a permanent lighting of the green LED (D6).

The electronics of the VSI-flow meters is able to detect three events, which may lead to measurement errors. Error are signaled by the red LED. Lighting up of this LED indicates events with negative effects on the measurement.

Table 7: Warning- and alarm messages

Warning		LED yellow	LED green	LED red	Warning message description
1	Configuration necessary	on	on	on	The preamplifier electronics has been replaced. A configuration has to be made before operating. There is no signal output.
Alarm		LED yellow	LED green	LED red	Alarm message description
2	GMR-pickup fault or interpolator error	on / off	on / off	on	Recognition of pickup breaking off or mechanical damage. The signal output may be incorrect.
3	Flow overload	on / off	on / off	on	The maximum permitted flow range has been exceeded.
4	Electronics error	flash	flash	flash	Defect component in the interpolator circuit. Error uncorrectable. There is no signal output.

18. PREAMPLIFIER TECHNICAL DATA

Pickup sensor	2 x AMR-sensor in a bridge circuit (sine and cosine signals) / pole wheel (26 pole pairs)
Configuration	automatically via peripheral board
Resolution	programmable 1, 2, 5, 10, 25, 32, 50, 64, 100, 128
Frequency	up to 100 kHz
Signal outputs	Channel A, channel B, direction signal „DIREC“ (high positiv; low negativ)
Channel A and B	Two signal outputs for emitting the digital flow meter signals; between channel A and channel B there is a channel offset of 90°
Flow direction	Recognition of flow direction from channel offset of the signals from channel A to channel B or from the separate direction signal on pin 5, direction can be changed by switch of the preamplifier electronics
Outputs	3 current limiting and short-circuit-proof push-pull output stages (channel A, channel B, zero signal Z); driver current approx. 200 mA at 24 V power supply; small saturation voltage up to 30 mA load current; short switching times; reverse voltage protection by integrated free-run diodes against V _b and GND; temperature protection switching with hysteresis; outputs are of high impedance in case of error; ESD protected
Pulse filtering	Selectable by jumper, filtering of pulses during a half turn of the scanned rotor, automatic storage of the preferred direction
Operating voltage	V _b = 10 . . . 28 VDC
Current consumption	I _{no-load} = approx. 40 mA; total current consumption depending on loading of outputs

19. PLUG ASSIGNMENT OF SEPARATED PREAMPLIFIER

Fig. 6 depicts the pin assignment of the separated preamplifier. This plug has five pins. Two pins are for the power supply (pin 1 and 3), two for the signal output of channel 1, 2 (pins 2 and 4) and a separate output for direction detection (pin 5).

As a rule, only the four outer pins are needed to evaluate the flow meter signals; pin assignment is therefore the same as standard RS-preamplifiers. For this reason you can use a normal 4 or 5-wired connection cable for the connection of the flow meter.

However, please note that the cable shield at the plug side is on the metal housing of the plug. The cable shield should always be continuous

to the separated preamplifier housing and not separated by distribution boxes or junction boxes. Route the connection cable as directly as possible from the evaluating device to the separated preamplifier since interruptions are always potential sources of error. In order to prevent interference either the shield should be connected to ground GND or to a protective earth conductor (PE). Alternatively the flow meter must be connected electrically to earth (PE). This is generally ensured with the grounded pipelines.

If potential differences exist between the preamplifier housing and the protective conductor (PE) of the evaluating device, you must provide equalization.

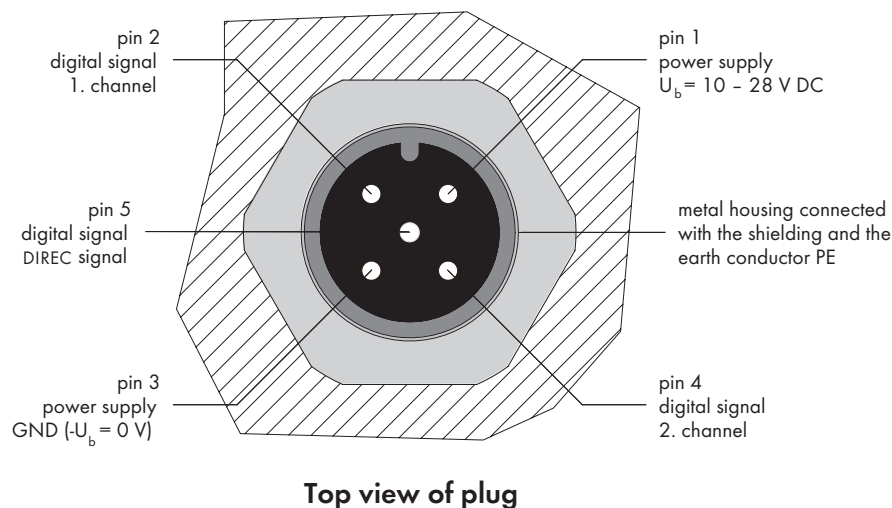

Fig. 6: Flange plug of the separated preamplifier

Important:

Only use well-shielded cables for the connection cable, with a wire cross section of ≥ 4 or $5 \times 0.25 \text{ mm}^2$. Please make sure that the housing of the round plug is metallic and that it has a connection to the shielding.



Important:

Please make sure that no additional inductors such as contactors, relays, valves, etc. are connected to the power supply of the flow meter. These components are potential sources of interference which produce high interference pulses during the switching, and may disrupt the function of the flow meter even though it complies with the EMC directives (especially if the inductors are not provided with adequate protective circuits).



20. MAINTENANCE, SERVICE LIFE AND WARRANTY

Depending on the operating conditions, the service life and therefore the specific properties of the units are limited by wear, corrosion, deposits or ageing. The operator is responsible for regular inspection, maintenance and recalibration. Any observation of a malfunction or damage prohibits further use. On request, we can provide you with a

loan unit for the duration of the overhaul. We recommend an annual check and recalibration. Under normal operating conditions, the service life is 10,000 hours.

The warranty period is 12 months.

Safety note:

Seals are not covered by the warranty, as they are parts that are subject to wear and tear. Over the course of time, the nature of plastics such as elastomer seals can change, in respect of flexibility, strength and toughness. Operating conditions have a decisive effect on the durability and lifespan of seals. Therefore, they should be checked, and if necessary, replaced, at regular intervals.



21. STORAGE, RETURN AND DISPOSAL

Temporary storage

All VSE flow meters are supplied with sealing plugs and in suitable packaging for all destinations and modes of transport to ensure optimum protection. The flow meters should always be stored in their original foam packaging or transport box.

The units must not be exposed to temperatures below -20°C or above +60°C and must be protected from moisture and its effects.

Return

1. The flow meter must be properly cleaned by the customer before being returned to prevent the risk of poisoning/contamination by harmful, explosive and other high-risk pumped media for humans and the environment.
2. If media have been conveyed whose residues with atmospheric humidity lead to corrosion damage or ignite on contact with oxygen, the flow meter must be additionally neutralised and thoroughly cleaned with anhydrous, inert gas to dry.
3. The return of the flow meter must always be accompanied by a fully completed declaration of no objection (see section 29, page 26). All applied safety and decontamination measures must be indicated.
4. When returning the flow meter, it must be packed in accordance with the applicable logistics standards and sealed with sealing plugs.

Disposal

VSE actively promotes environmental awareness and has an operational management system that meets the requirements of ISO 9001:2015. The impact on the environment and people should be minimised during the production, storage, transport, use and disposal of our products and solutions.

- Collect rinsing liquid as well as residual liquid and dispose of it in accordance with the statutory provisions and regulations.
- Wear protective clothing and protective mask/+ goggles if necessary.

Materials must be disposed of properly as follows:

- Metal
- Plastics
- Electronic components
- etc.

When disposing of the materials, ensure that the waste-relevant rules and regulations of the respective country of destination are observed!

22. RS-HT FLOW METER TECHNICAL DATA

Overall size	Measuring range l/min	RV cm ³ /Imp.	VE cm ³ /Imp.	K-Factor Imp./l (min)	K-Factor Imp./l (max)	p max. cm ³ /pulse	Filtrering µm
RS 25 - HT	in preparation						
RS 40 - HT	0.04 - 40 (50)	8.37	0.322	3,107	397,600	see chap. 23	100
RS 100 - HT	0.50 - 100 (120)	15.7	0.587	1,705	218,200	see chap. 23	250
RS 400 - HT	1.00 - 400 (525)	56.5	3.26	307	39,200	see chap. 23	250
RS 800 - HT	4.00 - 800 (1,000)	180.0	10.39	96	12,300	see chap. 23	500
RS 2500 - HT	10.00 - 2,500 (3,000)	666.0	38.42	26	3,330	40 bar	500

Frequency range	0 ... 100 kHz, adjustable	
Measuring accuracy	$\pm 0.5\%$ (1%)* of measured value at viscosity of 21 cSt / 21 mm ² /s	
Repeatability	$\pm 0.05\%$ with same operating conditions	
Materials:		
- Gray cast iron version	EN-GJS-400-15 (EN 1563)/16 Mn Cr 5 or 1.4112	
- Stainless steel version	Stainless steel 1.4305/1.4112, additional available upon request	
Bearing	Anti-friction bearing	
Seals	FPM (standard) upon request PTFE, NBR, EPDM, EPDM-41B8, silicone	
Fluid temperature	- 40°C / - 40°F ... + 200°C / 392°F (short-time +220°C / 428°F)	
Ambient temperature separated preamplifier	- 20°C / -20°F ... + 85°C / 185°F	
Viscosity range	1 ... 1,000,000 mm ² /s	
Installation position	Any using selectable connection units, also customer specific	
Supply voltage	10 ... 28 VDC	
Current consumption	65 mA at 24VDC unloaded	
Pulse output	3 current limiting and short-circuit-proof output stages low signal: 0 = GND; high signal: 1 = U _b -1	
Delay time	$\leq 8\mu\text{s}$	
Channel offset	90° \pm 5° max.	
Pulse-width repetition rate	1/1 \pm 5° max.	
Preamplifier housing	Aluminium	
Cable length to pick-up system	1.5m (standard) upon request up to 3m	
Protection type	IP 65 in mated condition	* RS2500

23. PRESSURE / TEMPERATURE LIMITS AND MAX. RATES OF TEMPERATURE CHANGE

Important:

The following diagram explicitly shows the operating limits regarding pressure and temperature, which must be observed. Please note that the maximum operating pressure of the RS2500 is generally specified as 40 bars and must not be exceeded. The sealing material must be correctly chosen for the particular application. This must be observed especially for application temperatures outside the range of -20°C / -4°F ... 120°C / 248°F. Please always consult VSE for the correct seals.

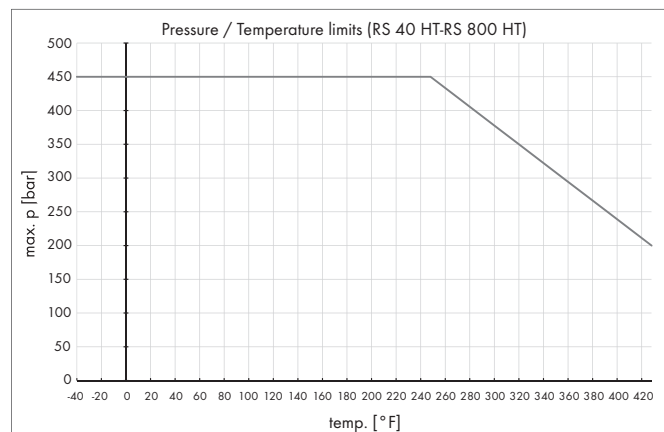
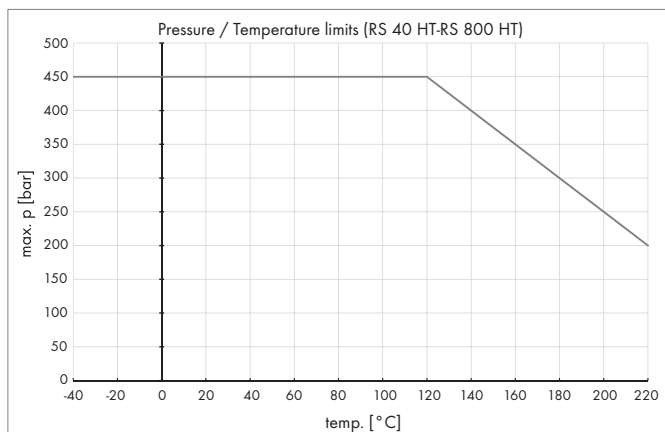

A maximum rate of temperature change must not exceed 6 K/min.

Size 25

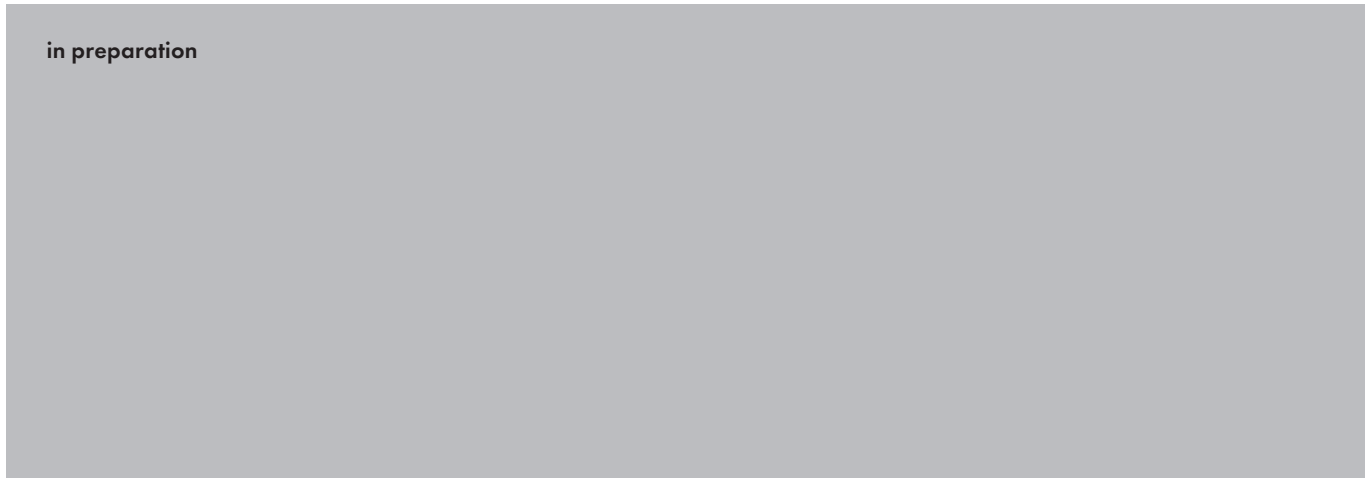

Size 40

Flow range 0 up to 50 l/min

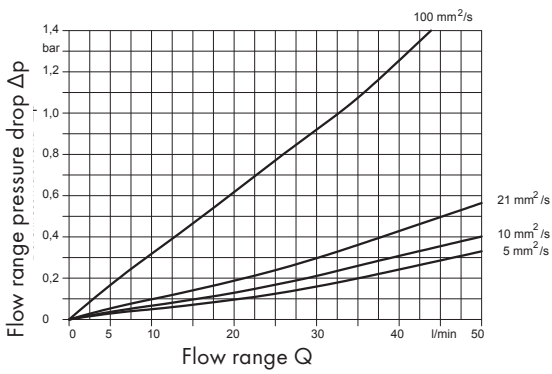

Flow range 0 up to 5 l/min

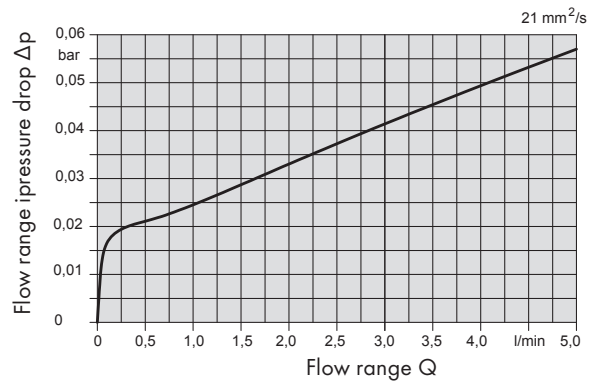

Size 100

Flow range 0 up to 120 l/min

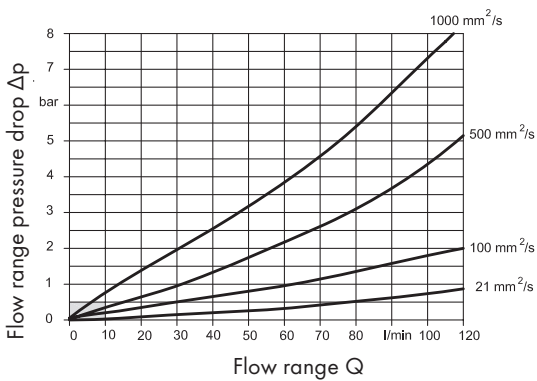

Flow range 0 up to 10 l/min

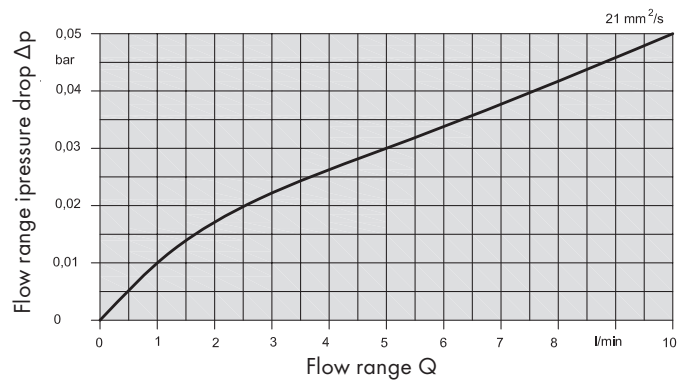

Size 400

Flow range 0 up to 500 l/min

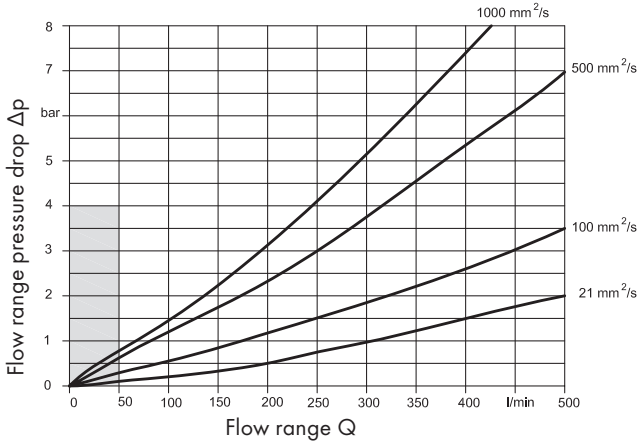

Flow range 0 up to 50 l/min

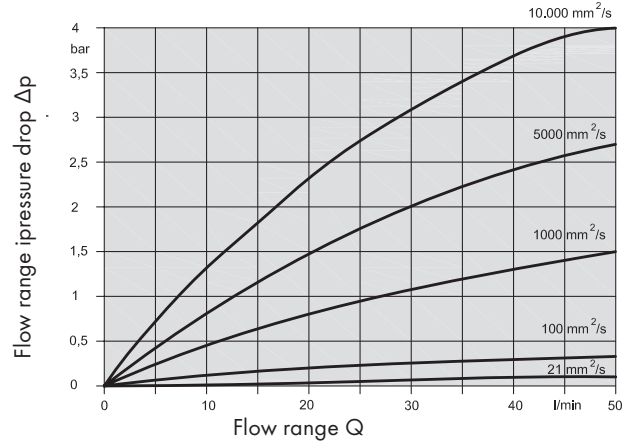

Size 800

Flow range 0 up to 1,000 l/min

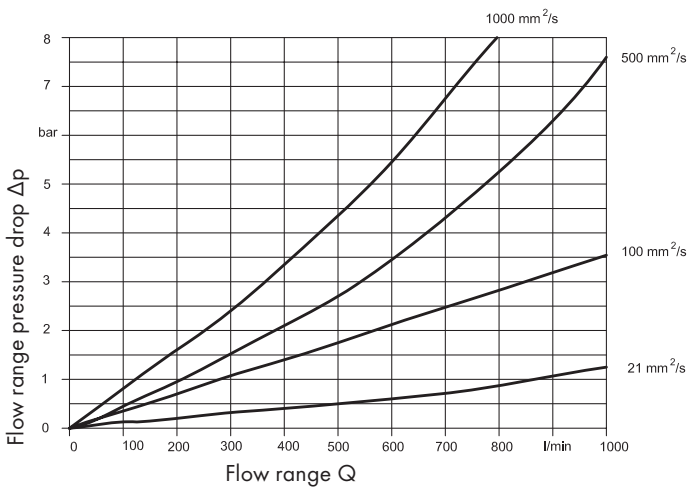

Size 2500

Flow range 0 up to 3,000 l/min

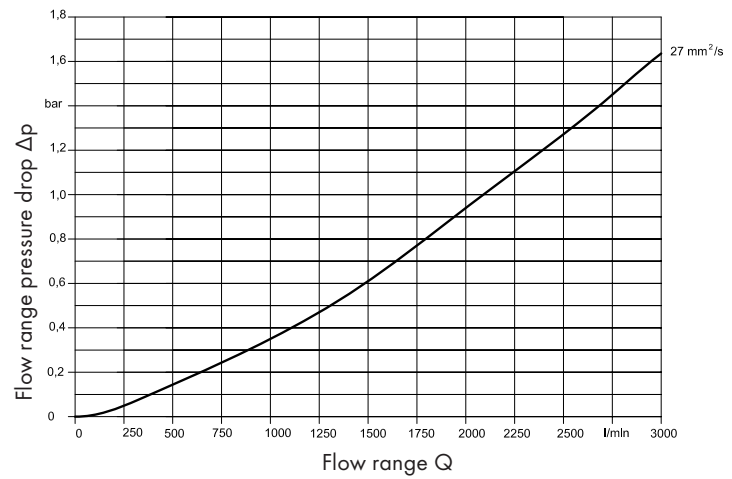

25. RS-HT FLOW METER DIMENSIONS

RS 25 - HT

in preparation

RS 40 - HT

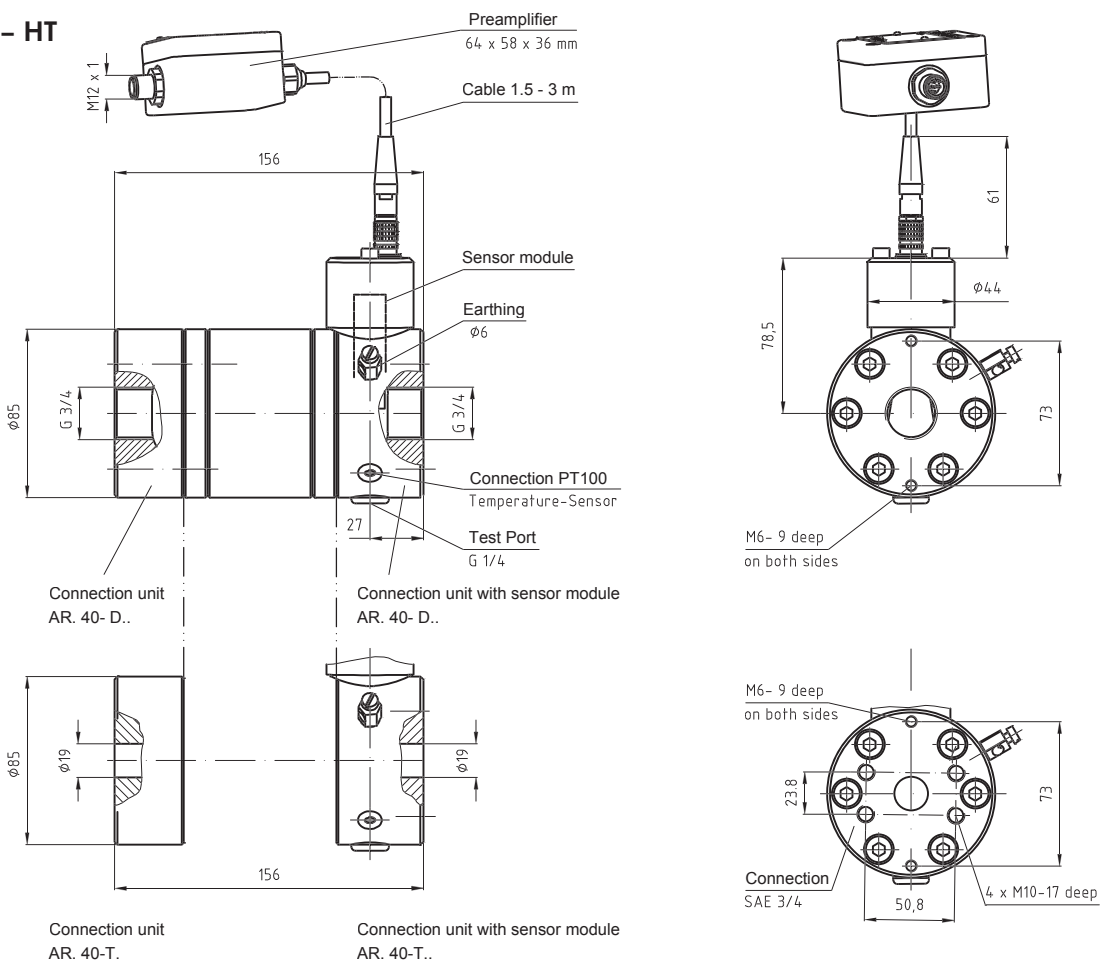

Weight:
 Version "G"
 6.0kg
 Version "E + X"
 6.5kg

RS 100 - HT

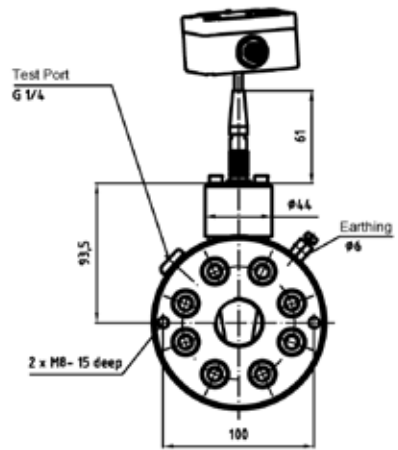
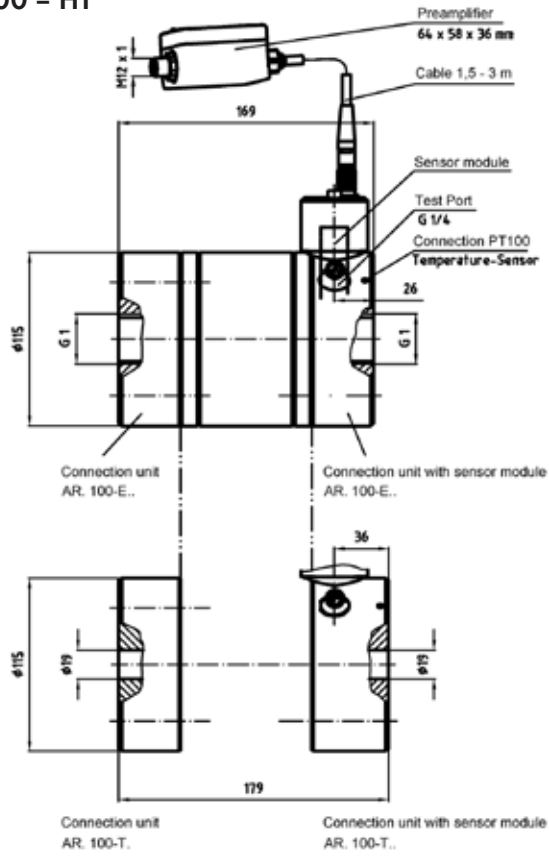

Weight 12kg

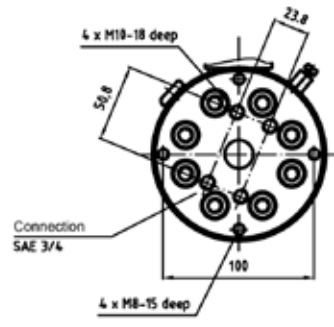

Weight 12.7kg

RS 400 - HT

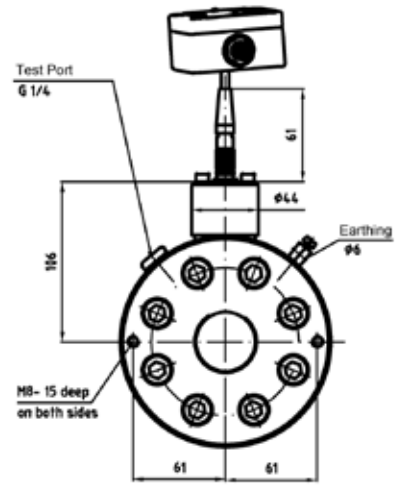
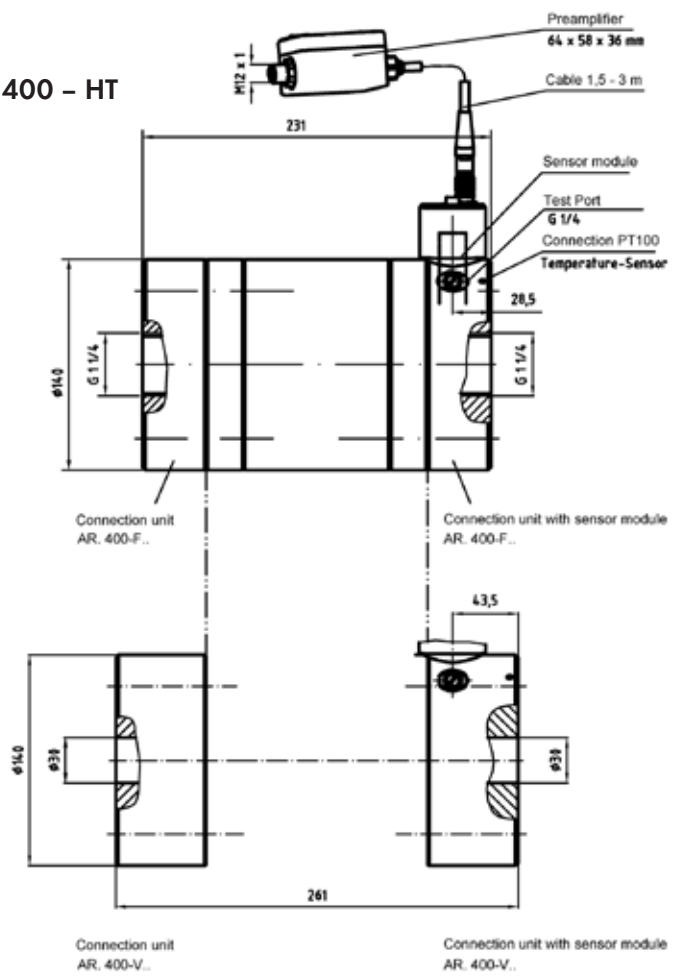

Weight 22kg

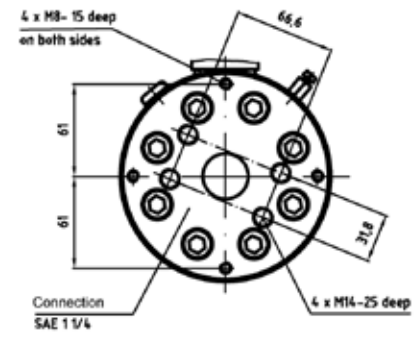

Weight 24.8kg

RS 800 - HT

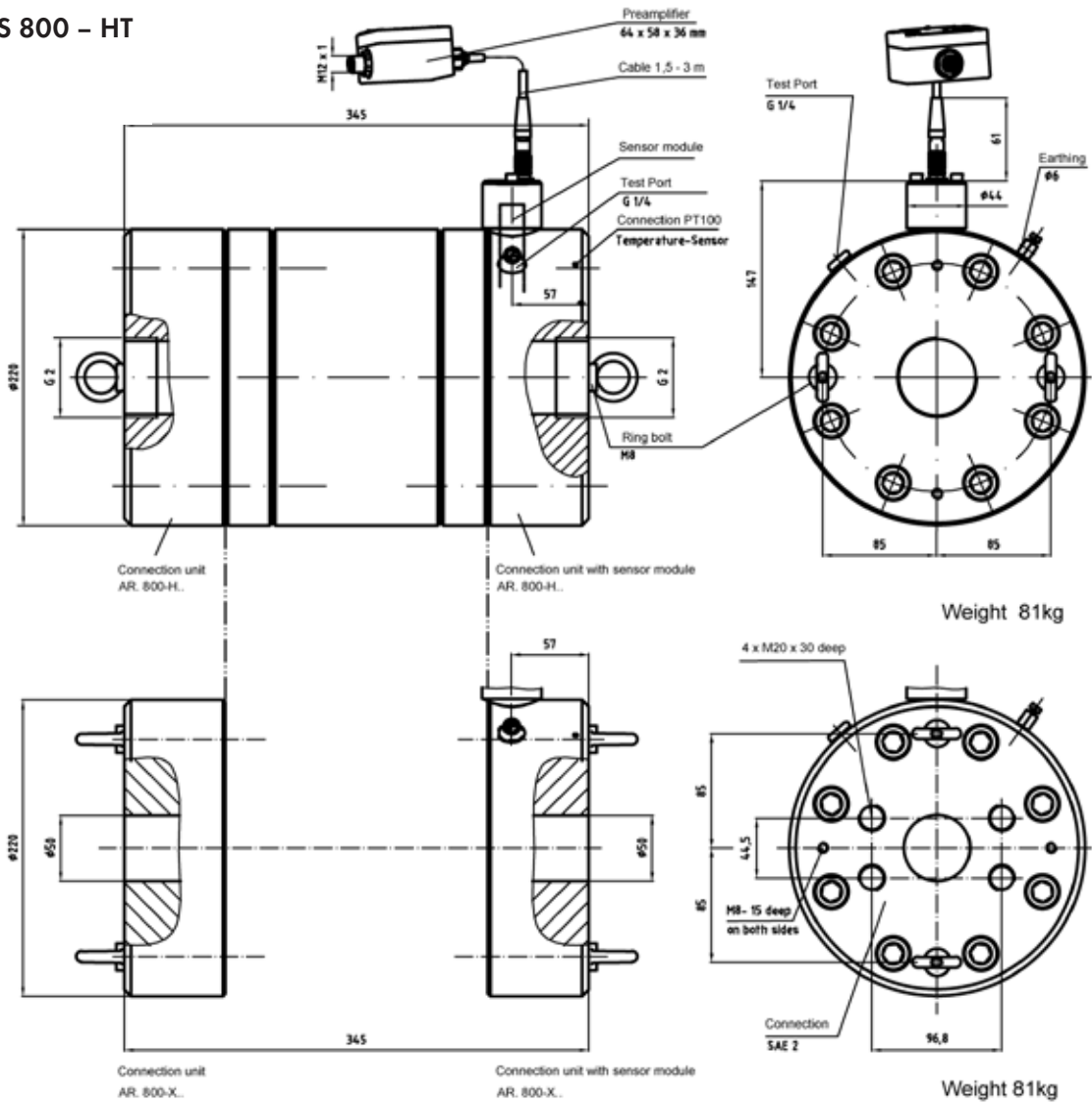

RS 2500 - HT

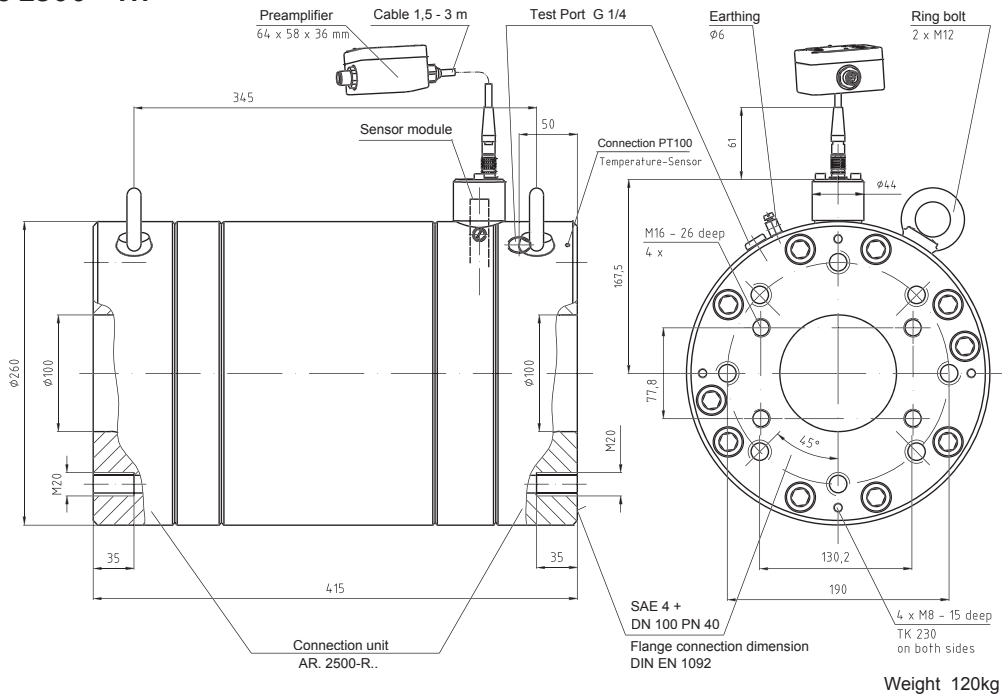

26. TYPE KEY

RS 25	In preparation											
RS 40												
RS 100												
RS 400												
RS 800												
RS 2500												
Size	1 2 5 10 25 32 50 64 100 128	Selectable interpolations factor										
		Interpolation	Material	G EN-GJS-400-15 (DIN EN 1563)								
				F Stainless steel 1.4305 (V2A)								
				X Stainless steel 1.4571 (V4A)								
			Connection type	R Pipeline connection								
				0 Standard								
	Factory-provided		Connection type	1 Ball bearing								
				6 Hard metal sleeve bearing								
				7 Angular contact ball bearing								
	Bearing		Backlash	2 Standard								
				V FPM (Viton) Standard								
				P NBR (Perbunan)								
T PTFE												
E EPDM												
B EPDM - 41B8												
S Silicone												
Sealing type	Version	HT Pick-up system for high temperatures										
		X Modification figure factory-provided										
Construction range	Construction range	X Modification figure factory-provided										
RS 800 /	50	G	R	0	1	2	V	-	HT	/	X	Flow Sensor

Example

AR	G	800	-	G	V	1	1	0	N	/	X	Connection unit		
Connection unit	Material	Size	Material	Interpolation	Material	Connection type	Factory-provided	Bearing	Backlash	Sealing type	Version	Construction range	Modification figure factory-provided	
														0 Without connection for PT 100
														1 With connection for PT 100
														0 Without test port G 1/4
														1 With one test port G 1/4
														2 With two test port G 1/4
														1 Sensor module GSM 01 - no longer valid
														2 Sensor module GSM 02 + Sensor module RS / HT
														V FPM (Viton) Standard
														P NBR (Perbunan)
														T PTFE
														E EPDM
B EPDM - 41B8														
S Silicone														
D G 3/4	H G 2	T SAE 3/4	Z SAE 4											
E G 1	I DN 100 P16	V SAE 1 1/4	Q DN 50 PN40											
F G 1 1/4	R DN 100 PN40	X SAE 2	Q1 DN 80 PN40											
G G 1 1/2		Y DN 20 PN10	Q2 DN 100 PN10											
25	RS 25	In preparation												
40	RS 40													
100	RS 100													
400	RS 400													
800	RS 800													
2500	RS 2500													
G	EN-GJS-400-15 (DIN EN 1563)													
F	Stainless steel 1.4305 (V2A)													
X	Stainless steel 1.4571 (V4A)													

27. PLUG ASSIGNMENT SEPARATED PREAMPLIFIER

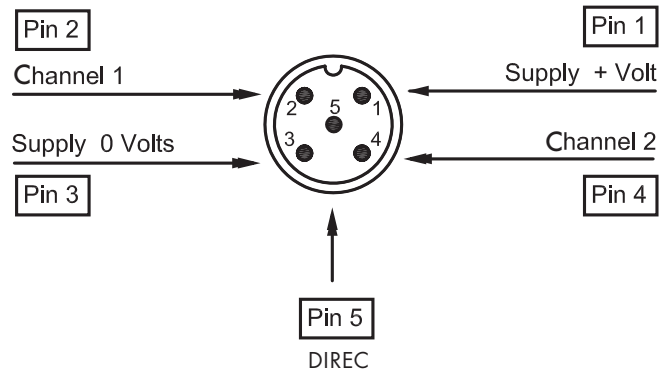
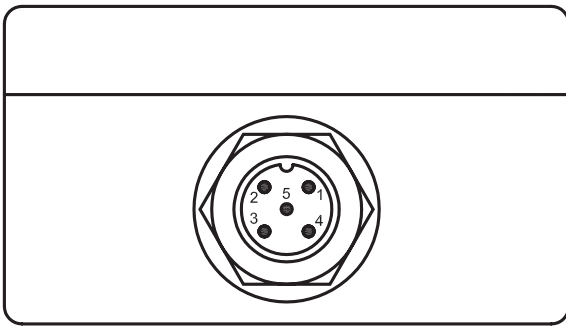

28. CONNECTION DIAGRAM

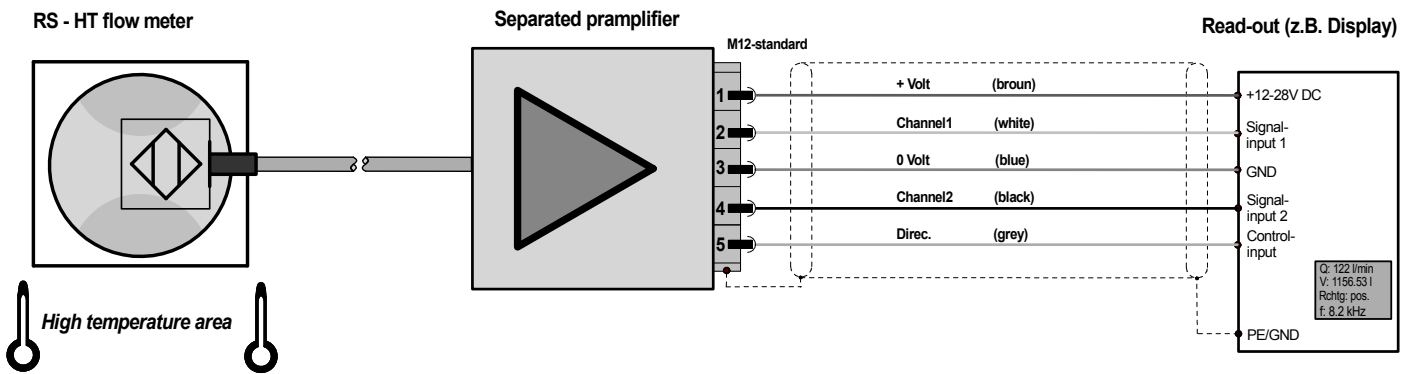

29. CERTIFICATE OF NON-OBJECTION



SAFETY DECLARATION FOR RETURN DELIVERIES (CERTIFICATE OF NON-OBJECTION)

Last revised: 10/2021

Please reply to info@vse-flow.com

Flow meters, for which this certificate of conformity has not been completed and signed, cannot be inspected or repaired for safety reasons and will be returned unchecked at your expense.

Article number	
Quantity	
Reason for return	

The flow meter was used in health/environmentally hazardous media.

 No

 Yes

The flow meter is free from residuals.

 No

 Yes

Special safety measures or treatment is necessary or expected.

 No

 Yes

The flow meter was last used with the following media:

If yes, which

	<input type="radio"/> No	<input type="radio"/> Yes*	
Solvents	<input type="radio"/> No	<input type="radio"/> Yes*	
Toxic liquids	<input type="radio"/> No	<input type="radio"/> Yes*	
Biologically active liquids	<input type="radio"/> No	<input type="radio"/> Yes*	
Radioactive liquids	<input type="radio"/> No	<input type="radio"/> Yes*	
Corrosive liquids	<input type="radio"/> No	<input type="radio"/> Yes*	
Alkali	<input type="radio"/> No	<input type="radio"/> Yes*	
Explosive liquids	<input type="radio"/> No	<input type="radio"/> Yes*	
Other media	<input type="radio"/> No	<input type="radio"/> Yes*	

* Please add the safety data sheet for the medium in the appendix.



SAFETY DECLARATION FOR RETURN DELIVERIES (CERTIFICATE OF NON-OBJECTION)

Please reply to info@vse-flow.com

The undersigned assures that the above information is correct and complete and the shipping is carried out according to legal regulations. The undersigned is liable for all damages which arise as a result of the non-marked decontamination of the returned flow meter.

VSE expressly points out that repairs and verification work is carried out by trusting the correctness of the completion of this safety declaration (certificate of non-objection). Should physical injuries, death or even damage to property occur, claims for damages will be asserted.

Company	
Street / Building no.	
Postcode / Town	
Phone	
Fax	
Email	

Contact
(in capitals)

Date

Signature
(company stamp)

Enclosed

VSE.flow®

VSE Volumentchnik GmbH
Hönnestraße 49
58809 Neuenrade / Germany

Phone +49 (0) 23 94 / 616-30

Fax +49 (0) 23 94 / 616-33

info@vse-flow.com

www.vse-flow.com

e.holding
FLUID TECHNOLOGY GROUP

www.e-holding.de