

Solutions for Fluid Technology



OPERATING INSTRUCTIONS

For Flow Meters of the Product Series "Ex-Type VHM"



TABLE OF CONTENTS

	Page
Important information and legal notices	3
General function description of flow meter for Ex-hazardous areas	4
General description	4
Flow meter selection	4
Declaration of Conformity	4
General conditions for initial start-up	4
Maximum operating pressure	5
Information on EU Directive 2014/68/EU On pressure equipment	5
Flow rate range	6
Assembly of the flow meter	6
Cleaning and flushing the pipes before initial start-up	7
Flow meters for explosion hazardous areas	8
Isolation amplifier MK 13-P-Ex0/24VDC/K15	9
Installation of VSE flow meters in explosion hazardous areas	11
Control Drawings	13
Preamplifier for Ex-Type VHM series	15
General information	15
The single pick-up	15
The dual pick-up	15
Application with directional detection	16
Safety instructions for installation and operation in hazardous areas	18
Maintenance, service life and warranty	19
Storage, return and disposal	19
Technical data for the VHM flow meter	19
Dimensions for VHM flow meter	20
Dimensions of the AHM mounting plate	21
Type Code for VHM/AHM	22
Technical data for VIL*-*S**/Ex, VTL*-*S**/Ex single pick-ups	23
Electronic connection data for VIL*-*S**/Ex, VTL*-*S**/Ex	23
Housing data for VIL*-*S**/Ex, VTL*-*S**/Ex, Type Plate for VIL*-*S**/Ex, VTL*-*S**/Ex	23
Technical data for VEL*-*S**/Ex single pick-ups	24
Electronic connection data for VEL*-*S**/Ex	24
Housing data for VEL*-*S**/Ex, Type Plate for VEL*-*S**/Ex	24
Technical data for VDL*-*S**/Ex dual pick-ups	25
Electronic connection data for VDL*-*S**/Ex	25
Housing data for VDL*-*S**/Ex, Type Plate for VDL*-*S**/Ex	25
Type codes - signal pick-ups	26
Technical data for VHM Titan	27
Dimensions for VHM Titan	27
Type code VHM Titan	28
Technical data for single pick-ups VRL*-*S**/Ex; VWL*-*S**/Ex for VHM Titan	29
Electronic connection data for VRL*-*S**/Ex; VWL*-*S**/Ex for VHM Titan	29
Housing data for VRL*-*S**/Ex; VWL*-*S**/Ex for VHM Titan, Type Plate for VRL*-*S**/Ex; VWL*-*S**/Ex for VHM Titan	30
Type code - signal pick-up for VHM Titan	30
Wiring diagram with isolated switching amplifier	31
Media and ambient temperatures	31
Flow meter labels and certifications	31
Summary of the safety-related technical data	32
Certificates	33
Certificate of Non-Objection	40

The current publication of this operating instruction supersedes all information from previous publications. VSE reserves the right to make changes and substitutions. VSE is not liable for any printing errors. Reproduction, including excerpts, is permitted only after written approval by VSE. VSE reserves the right to modify technical data at any time. Last revised: 02/2022



IMPORTANT INFORMATION AND LEGAL NOTICES

Dear customer, dear user,

This operating instruction for volume sensors of the “**Ex-Type VHM**” series by VSE Volumentchnik GmbH (VSE) contains information required to properly install and commission the flow meter in potentially hazardous areas according to the regulations.

Any installation, commissioning, operation, maintenance and testing may only be carried out by trained and authorized personnel with knowledge of the national regulations relating to explosion protection. The operating instructions must be read and followed carefully to ensure a trouble-free, proper and safe operation of the flow meter. In particular, the safety instructions are essential.

These operating instructions must be kept safe and accessible for the authorized personnel at all times. At no time should contents of the operating instructions be removed. A missing manual or missing pages must be replaced immediately if lost. The operating instructions can be requested at any time from VSE or downloaded from our website www.vse-flow.com. The operating instructions must be passed on to each subsequent user of the flow meter.

This operating instruction is not subject to any modification service by VSE. VSE reserves the right to make technical changes at any time without notice.

VSE makes no warranties, express or implied, with respect to commercial qualities and suitability for a particular purpose.

VSE accepts no liability for damage and malfunctions resulting from operating errors, failure to observe these operating instructions, improper installation, commissioning or maintenance as well as improper use of the flow meter.

The opening of the flow meter is absolutely not permitted. After an unauthorized opening or rebuilding as well as after a single, incorrect connection of the flow circuits of the flow meter, the warranty as well as the product liability by VSE expire.

GENERAL FUNCTION DESCRIPTION OF FLOW METER FOR EX-HAZARDOUS AREAS

Flow meters made by VSE Volumentech GmbH measure the volume flow of liquids according to the toothed wheel principle. A pair of very precisely adjusted toothed wheels in the housing constitutes the meter. A signal pick-up system registers meter rotation free of contact and tooth by tooth. Each tooth is put out as one single, two or four pulses, depending on the type of the pick-up system.

The gaps in the teeth of the meter wheels form meter chambers in the areas, in which they are completely enclosed by the housing walls; the

se chambers digitalise liquid flow depending on their chamber volume. The liquid flow quantity within one meter rotation of a tooth division forms the volume measurement per pulse (V_m) and is defined in cm^3/pulse . It identifies the constructional size of a flow meter.

$$V_m (\text{l/Imp}) = 1/\text{K-factor}$$

The "Ex-type VHM" generates a modulated digital current signal which is digitalized and amplified by an isolation amplifier.

GENERAL DESCRIPTION

Please follow all instructions in this operating manual; only this guarantees a trouble-free operation of the flow meters. VSE is not liable for any damage ensuing from non-following of these instructions.

Opening the devices during the term of guarantee is only authorised after consultation and approval of VSE.

FLOW METER SELECTION

The correct selection (version) of type and constructional size is crucial for a trouble-free and safe operation of the flow meters. Owing to the great number of various applications and flow meter versions, the technical specifications in the VSE catalogue material are of a general

nature. Performance of the flow meter depends on type, size and meter range and on the liquid that is to be measured. Please consult VSE for an exact description.

DECLARATION OF CONFORMITY

Flow meters of the "VHM" product line are tested for their electromagnetic compatibility and interference transmission in terms of the law on electro-magnetic compatibility and correspond to the legal prescriptions enforced by EMC directives. They may not be operated independently and are to be connected via cable to a power source and supply digital electric signals for electronic evaluation.

All flow meters are tested according to the valid, legally prescribed electromagnetic compatibility directives.

Since the electromagnetic compatibility of the total measuring system depends as well on cable layout, correct connection of protective shielding and each single connected device, you must ensure that all components correspond to the electromagnetic compatibility directives and that the electromagnetic compatibility of the total system, machine or plant is guaranteed.

"Ex-Type"-flow meters from VSE are authorized for use in explosion hazardous areas and comply with the safety requirements of the ATEX directive 2014/34/EU and the relevant European standards. These flow meters are certified by an accredited body. The certificate can be found in this operation manual. A copy of the declaration of conformity is to be supplied with each "Ex-Type" product that is delivered.

GENERAL CONDITIONS FOR INITIAL START-UP

Before assembly and before initial start-up, you have to note the following properties and aspects of the corresponding characteristics of your system, so that a trouble-free and safe operation is possible.

1. The process fluid

- Is the flow meter **suitable for the fluid**?
- Is the fluid **viscous or abrasive**?
- Is the fluid **contaminated** or is there **solid matter** in the fluid?
- Which **granular size** does the solid matter possess and can it **block the meter**?
- Does the fluid have **fillers** or other **additional material**?
- Is it necessary to install a pre-switched **hydraulic filter**?
- Are the **pipe lines clean** and free of assembly residues such as swarf, weld chips?
- Is the **tank clean** and is it ensured that **no extraneous materials** can get into the pipe line system from the tank?
- Is the fluid often changed and is **sufficient flushing performed in this case**?
- Are the pipe lines and the entire system completely **deaerated**?
- What **cleaning agent** is being used?
- Are the fluid and the cleaning agent compatible with the **seals**?
- Are the **seals suitable** for the fluid undergoing measurement (**seal compatibility**)?

2. The hydraulic properties of the system

- Is the **max. operating pressure of the system** lower than the max. permitted operating pressure of the flow meter?
- Is the **max. fall of pressure Δp** (on flow meter) below the max. permitted fall of pressure?
- Does an excessively **great fall in pressure Δp** occur on the flow meter at max. flow (e.g. with higher viscosity)?
- Does the flow range of the flow meter (depending on viscosity) correspond to the **provided flow**?
- Note that flow range decreases the **greater the viscosity!**
- Does the temperature range of the flow meter correspond to the **provided max. temperature** of the medium?
- Is the **cross section** of the pipe line large enough and are the falls in pressure in the system not excessive?
- Is the **hydraulic connection** (supply and reverse flow) correctly connected and leak-proof?
- Has the **pump** sufficient power to operate the system?
- A blocking flow meter can stop the whole flow. Is a **pressure control valve / bypass** provided in the system?

3. Electronic evaluation and electrical safety

- Have you selected the optimal flow meter and is this equipped with the **appropriate preamplifier**?
- Does the **power supply voltage** of the flow meter correspond to the provided voltage?
- Is the power supply voltage supplied by the mains or evaluation device sufficiently **steady**?
- Does the **output** of the power supply voltage correspond to the required power output?
- Has the electric connection been installed based on the enclosed **connection plan**?
- Is the cable **protected** by a shielding?
- Is there a **connection** of the cable protective shielding via the 4-pin round plug to the housing of the flow meter?
- Is there a **potential difference** between the earth conductor connection PE on the flow meter and the earth conductor PE on the evaluation device?
- Does a compensating cable have to be laid to eliminate the **potential difference** between the flow meter and the evaluation device?
- Is the flow meter connected firmly to the **earth conductor PE** (e.g. via the pipe lines)?
- Is the flow meter mounted to be **insulated** to the earth conductor PE (e.g. connection via hoses)? If this is the case, the earth conductor PE has to be connected to the flow meter!
- Is the cable laid fault-free and the installation secured from input of **interference pulses**?
- Is the **round plug** of the connection cable firmly screwed together with the plug of the flow meter?
- Are the wires on the **evaluation device** correctly and properly connected?
- Are the wires on the **isolation amplifier** correctly and properly connected?
- Does the entire system correspond to the directives of the electromagnetic compatibility laws (**EMC**)?
- Have all local valid regulations, **applicable directives**, guidelines and background conditions of the **explosion protection and electromagnetic compatibility laws** been maintained and observed?
- Systems that can lead to personal injury through malfunction or failure are to be equipped with the **appropriate safety devices**. The functioning of these safety devices is to be checked at **regular intervals**.

MAXIMUM OPERATING PRESSURE

Before assembling the flow meter, you have to test that the max. operating pressure of the system does not exceed the max. permitted operating pressure of the flow meter. Meanwhile, observe the top pressures that can occur, when operating the system.

The following operating pressures are permitted depending on flow meter version:

- Flow meter "VHM" $p_{\max} = 250 \text{ bar} / 3600 \text{ psi}$
- Flow meter "VHM Titan" $p_{\max} = 10 \text{ bar} / 145 \text{ psi}$

INFORMATION ON EU DIRECTIVE 2014/68/EU ON PRESSURE EQUIPMENT

In terms of Article 2, No. 5 of the directive named above, VSE volume sensors are so-called "pressuremaintaining components" and this directive thereby relates to them.

VSE volume sensors must thereby comply with the technical requirements named in Section 4 of the directive in accordance with Article 4, Paragraph (1d), Piping according to Paragraph (1c).

Typically, the fluids measured fall into Group 2 in accordance with Article 13, Paragraph (1b). The volume sensors sold by VSE do not comply with the limit values defined under Article 4, Paragraph (1a).

The technical requirements on volume sensors from VSE are therefore limited to the criteria defined in Article 4, Paragraph (3). That means that the devices must be designed and manufactured in accordance with the good engineering practices prevailing in the member state. We hereby confirm this. The paragraph also states that these units may not bear the CE label named in Article 18.

A CE declaration of conformity is therefore not issued in accordance with 2014/68/EU.

The CE label of our volume sensors refers to Directive 2014/30/EU.

FLOW METER RANGE

The flow meter range specified in the flow meter data sheet ($Q_{\min} - Q_{\max}$) refers to the testing fluid "hydraulic oil" with a viscosity of $21 \text{ mm}^2/\text{s}$ at a temperature of 20°C . For this flow meter range, VSE specifies measurement accuracy of up to 0.5% of the measurement value and a repetition accuracy of 0.5%.

For fluids of lower viscosity of $1 - 10 \text{ mm}^2/\text{s}$ measurement accuracy deteriorates up to 1%, while for fluids of higher viscosity ($> 21 \text{ mm}^2/\text{s}$) it can improve.

Important:

Make sure that the specified maximum permitted operating pressure of the flow meter cannot be exceeded, whatever the operating mode of the system. Note the flow meter range that is dependent on the viscosity of the fluid to be measured.



ASSEMBLY OF THE FLOW METER

The flow meter should be mounted on an easily accessible location, so that dismantling for cleaning the meter presents no problem. Since flow meters can work in any installation position and flow direction, you can mount it on any location of your system that you wish. Take care when installing the flow meter that always liquid remains in the flow meter even at system standstill and that it can never run empty. The outflow of the flow meter should therefore always show a certain back pressure. In critical cases or when the pipe line is at standstill or standby and can run empty, we recommend installing an extra non-return valve in the outflow line.

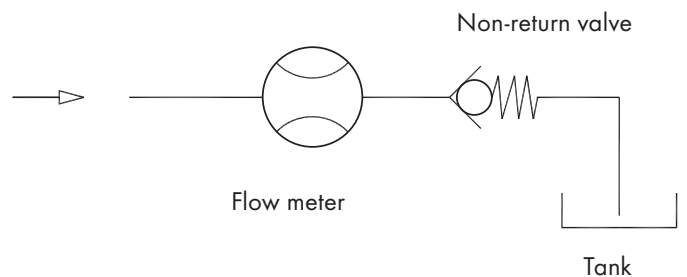

Fig. 1: Flow meter installation with non-return valve

Important:

Make sure that the flow meter is always completely filled both in inflow and outflow and that the outflow has a little back pressure. This prevents the meter being damaged by a sudden and steep increase of flow and at the same time improves measurement accuracy.



Flow meters of the "VHM" product line can be mounted directly onto a subplate installed in the pipe line. Always select large cross sections for the hydraulic supply and return flow respectively for the entire pipe line system (if possible). This lowers the fall in pressure and the flow rate in the total system.

VSE supplies subplates for all flow meters of the "VHM" product line; they have various pipe threads and side or rearside connection. Depending on the provided conditions, the installed pipe line, the pipe cross section or pipe thread, the operator can choose the suitable subplate and incorporate this into the system or machine without additional reductions.

The flow meter is screwed onto the subplate with cheese head screws.

Tighten the screws by hand. In special cases, the flow meter can also be mounted directly in the pipe.

Important:

When mounting the flow meter, you must take great care that the seals are not damaged and correctly placed in the hydraulic connections of the flow meter. Wrongly installed or damaged seals lead to leakage and to an leaky system, which may have dire consequences.

Please make sure that flow meters with EPDM seals do not come into contact with oil and greases on a mineral oil basis. These fluids can decompose the seals.

The yellow plastic plugs in the hydraulic connections of the flow meter protect the meter against dirt and contamination during storage and shipping. Before mounting the flow meter you have to remove these plugs so that in- and outflow is free and open.



CLEANING AND FLUSHING OF PIPE LINES BEFORE INITIAL START-UP

Before initial start-up of the flow meter, you must flush and clean the whole system. Contaminated fluids can affect the correct function of the flow meter or seriously damage the meter.

After preparing and connecting up the system pipes, you must first carefully flush and clean the whole pipe line system and the tank. To do this, you have to mount a diversion plate onto the block or subplate instead of the flow meter, so that the fluid can flow through the diversion plate and all extraneous material (e.g. swarf, metal chips, etc.) can be flushed out without obstruction. Use a fluid as cleansing agent, which is compatible with the fluid being used later and which does not cause undesirable reactions. You can consult the suppliers and manufacturers of the fluid or contact VSE for the corresponding information. VSE supplies bypass-plates the corresponding for all VHM flow meter sizes.

Flow meters are measurement pick-up systems made with high-level precision. They have a mechanical meter consisting of two toothed wheels and which is adapted to the housing with narrow slots. Even the tiniest damage to the toothed wheels and bearings can cause a measurement error. So always make sure that no extraneous material gets into the meter and that the fluid flowing through is always free from dirt and contamination.

After the system has been carefully flushed out and no extraneous material is in the pipe line, you can mount the flow meter and commence the initial start-up.

Important:

Please flush out the pipe lines and the tank thoroughly, to prevent contamination with the flow meter. A blocking flow meter can stop the whole flow. You have to provide a control valve / bypass for the system.



FLOW METER FOR EXPLOSION HAZARDOUS AREAS

The operation of flow meters in areas with a hazard of explosion is subject to very specific legal regulations. For this reason, only flow meters with a registered certification are permitted to be used in explosion hazardous areas.

To protect people from harm and equipment from damage, national and international regulations must be followed when using electrical components and systems in explosion hazardous areas.

Danger of explosion can arise when handling flammable substances. A hazardous situation occurs when these gaseous substances mix with oxygen have reached a dangerous level.

In this case a potential source of ignition like sparks or higher temperatures can lead to an explosion, which can injure people and damage plants or buildings.

All electrical devices which are used in explosion hazardous areas must be approved and marked for the relevant Ex-zone.

The Ex-zone classification depends on the frequency and duration of the explosive atmosphere and must be specified by the operator of the plant.

Ex-Type flow meters from VSE are suitable for intrinsically-safe "ia/IS" circuits and are certified for Zone 0/Division 1 (gas). They must always be operated with an isolation preamplifier. The special isolation preamplifier, which is supplied from VSE, provide the intrinsically safe "ia/IS"-circuits and are certified as associated electrical apparatus.

Intrinsically safe and non-intrinsically safe circuits must always be wired separately.

You can find relevant connection diagrams under "Installation of VSE flow meter in hazardous areas".

The Ex-Type VHM is approved for EEX ia IIC T6 ... T4 (ATEX) and for IS CL1 Div.1 GRPS A, B, C, D T4 ... T6.

The permitted ambient and media (fluid) temperatures for the Ex-Type VHM flow meter are classified for the corresponding temperature classes (T4, T5 or T6) and must be observed!

Please see "Maximum ambient and media temperatures".

The system Ex-Type flow meter and isolation amplifier is based on intrinsically safe circuits. The devices are approved by authorised bodies for use in those countries to which the approval applies.

For correct usage in explosion hazardous areas please observe and follow the national regulations and directives strictly. Following please find some guidelines referring to the actual frame-work directive of the European Union (ATEX), of the US (NEC) or of the corresponding country.

The special "TURCK"-isolation preamplifier, which is delivered by VSE, is classified as associated apparatus which is equipped with an intrinsically safe and a non-intrinsically safe circuit. It may only be installed in the non-explosion hazardous area in dry clean and well monitored locations. The Ex-type flow meter is wired to the blue intrinsically safe terminals of the preamplifiers as intrinsically safe equipment. Please note: Once that intrinsically safe circuit has been connected to the non-intrinsically safe circuit, it is not permitted to use the device subsequently as intrinsically safe equipment. The Ex-Type VHM must be operated by isolation preamplifier.

The VSE-Cable for the intrinsically safe circuit is also marked with blue color. It must be separated from the non-intrinsically safe circuit.

Please observe the specified clearances between the intrinsically safe connections and the grounded components and connections of other devices.

If the flow meter or an isolation preamplifier is opened by a person other than the manufacturer the approval becomes void.

Important:

The installation and connection of the Ex-Type flow meter and the isolation amplifier are only to be performed by trained and qualified personnel with knowledge of the relevant national regulations to explosion protection.

The most important data of the Ex-Type flow meter can be found under the corresponding "Safety data" of this manual.



ISOLATION AMPLIFIER MK 13-P-EX0/24VDC/K15

The isolation amplifier MK13-P-Ex0/24VDC/K15 from "TURCK" allows electrically isolated transmission of digital impulses. The intrinsically circuit is electrically isolated from the output circuit and the supply voltage.

The PNP-output stages of the isolation amplifiers provide the digital impulses for further evaluation.

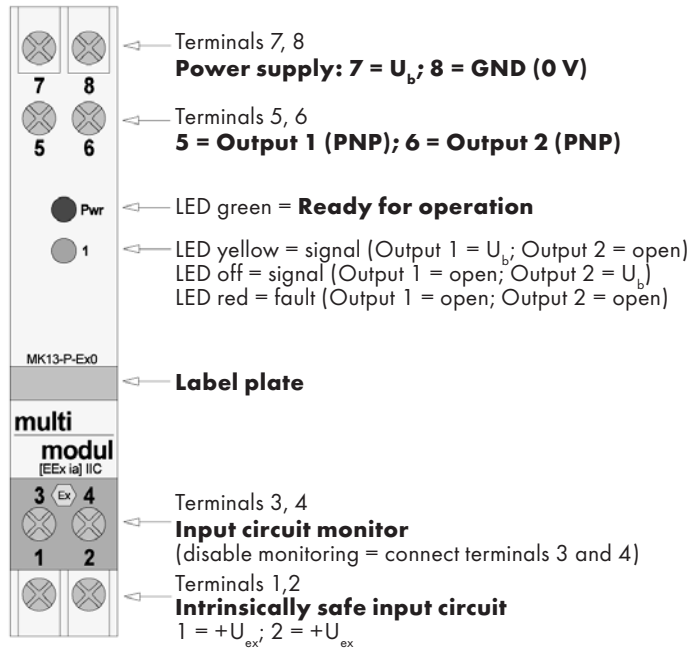

Figure 2: View of the isolation amplifier MK 13-P-Ex0/24 V DC/K15

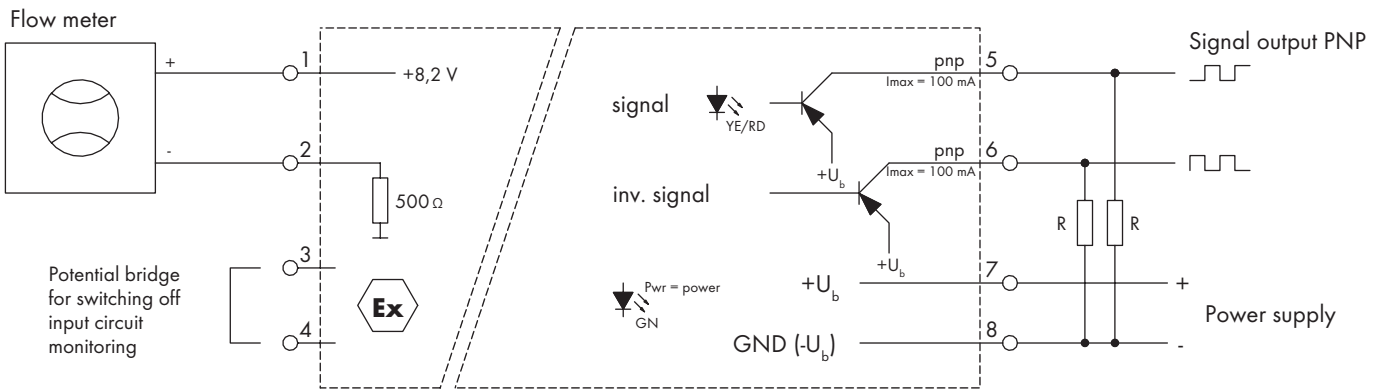

Figure 3: Circuit diagram of the isolation amplifier MK 13-P-Ex0/24 V DC/K15

The Ex-Type VS flowmeter outputs digital current modulated signals ($I_{low} < 2.7 \text{ mA}$; $I_{high} > 3.7 \text{ mA}$), which are processed in the isolation amplifier.

The digital current modulated signals are transmitted only by two wires for each channel. From these signals the isolation amplifiers create positively switching output signals (PNP-signals).

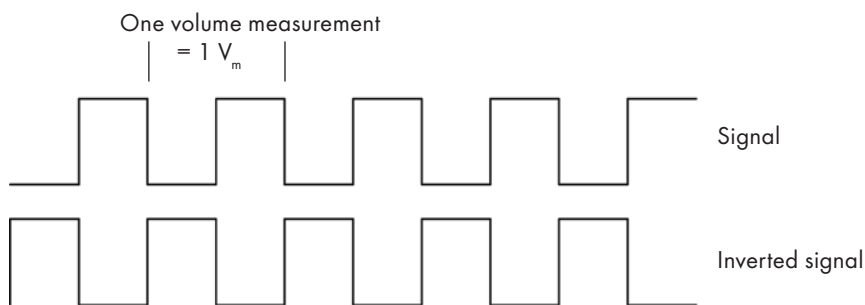

Figure 4: Signal output of the isolation amplifier

Note:

Note that the signal output of the isolation amplifier is a PNP-signal (low signal = open output; high signal = U_b). Problems may arise, when the signal processor has high impedance inputs, especially in the higher range of flow rates. The signal edges become rounded, and the signal processor cannot detect the digital signal any more. In this case, insert a pull-down resistor with a resistance of approx. 2.2 – 4.7 k Ω parallel to the input of the signal processor (see figure 3; Resistor R).



Information:

The Technical data for the isolation amplifier MK 13-P-Ex0/24 V DC/K15 from "TURCK" you find in the enclosed leaflet.

INSTALLATION OF VSE FLOW METERS IN EXPLOSION HAZARDOUS AREAS

The following figures show the connection diagrams for Ex-Type VHM flow meters for use in areas subject to an explosion hazard. Please connect each piece of equipment as shown in the diagram. Isolation amplifiers also contain non-intrinsically-safe circuits and may not be installed in hazardous areas.

You must always make sure that the grounded conductor "PE" is correctly connected with the flow meter and that no voltage differences can arise between the grounded conductor PE connections (flow meter » isolated switching amplifier » electronic signal processor). To accomplish this, always install an extra wire connection (about Ø 4 ... Ø 6 mm²) between each of the pieces of equipment (see the PE arrows in the following figures) or connect every single PE connection point in a star configuration to a specific location on the grounded conductor PE. There is a terminal for this on the flow meter. A conductor with a minimum diameter of 4 mm² can be connected here.

VSE supplies connection cables for EMC-safe operation in which the shield is seated on the union nut of the four-pin circular connector. It is not necessary to connect the shield to a ground connection at the other end of the connection cable, but it is recommended.

Important:
Mounting and installation must always be performed according to the locally applicable regulations and the operator of the plant is responsible for ensuring that these regulations are complied with.
You must make sure that no voltage differences can arise between the pieces of equipment and must install potential equalization!
Please particularly observe the safety instructions in this manual.



The connection diagram in figure 5 shows the processed signal from the flow meter. With this measuring system you can measure the flow rate and the volume in one direction.

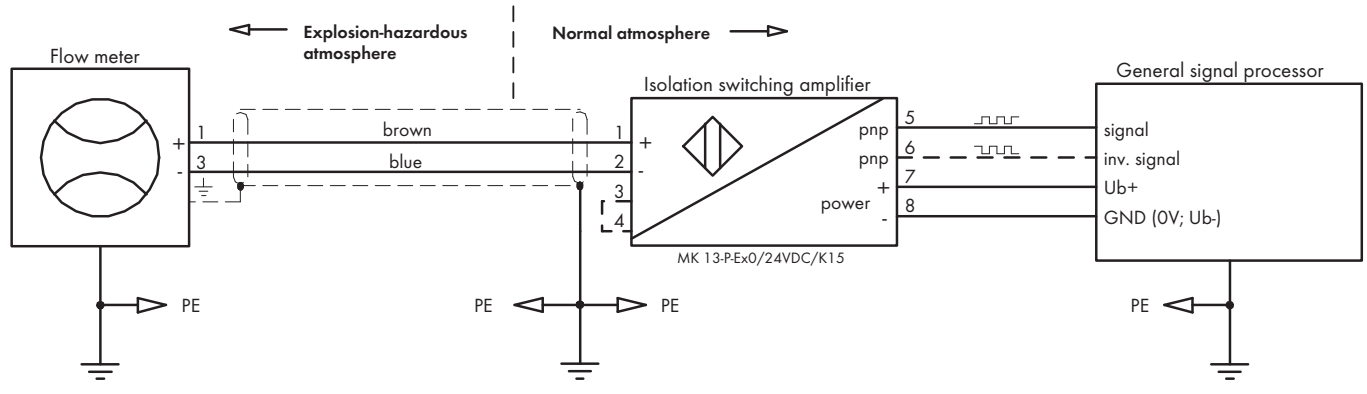

Figure 5: Connection diagram for the Ex-Type VHM measuring system

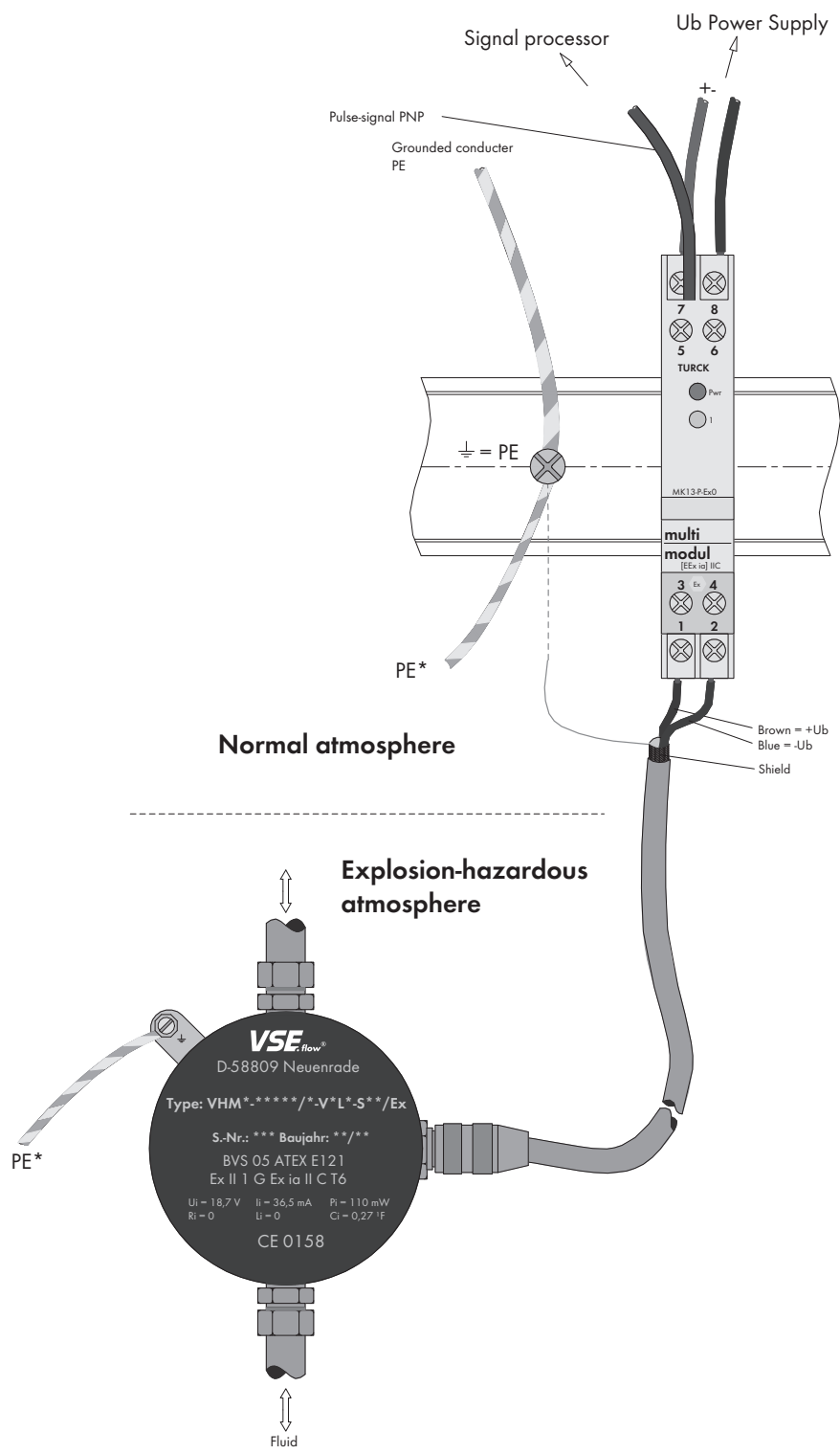

Figure 6: Connecting of the flow meter and isolation amplifier

Important:
Persons assigned or contracted to install, commission and operate the devices must have relevant qualifications for the job. In particular, they must have knowledge of explosion protection.



Hazardous (Classified) Location

Class I, Division 1, Groups A, B, C & D T4...T6

Note: T4...T6 temperature code based on 50 °C (122 °F)

Flow Meter System Series
VHM *-***/*-V*L*S**/Ex**

Unclassified Location

ASSOCIATED APPARATUS
Isolator barrier MK13-P-Ex0/24VDC/K15
(TURCK)

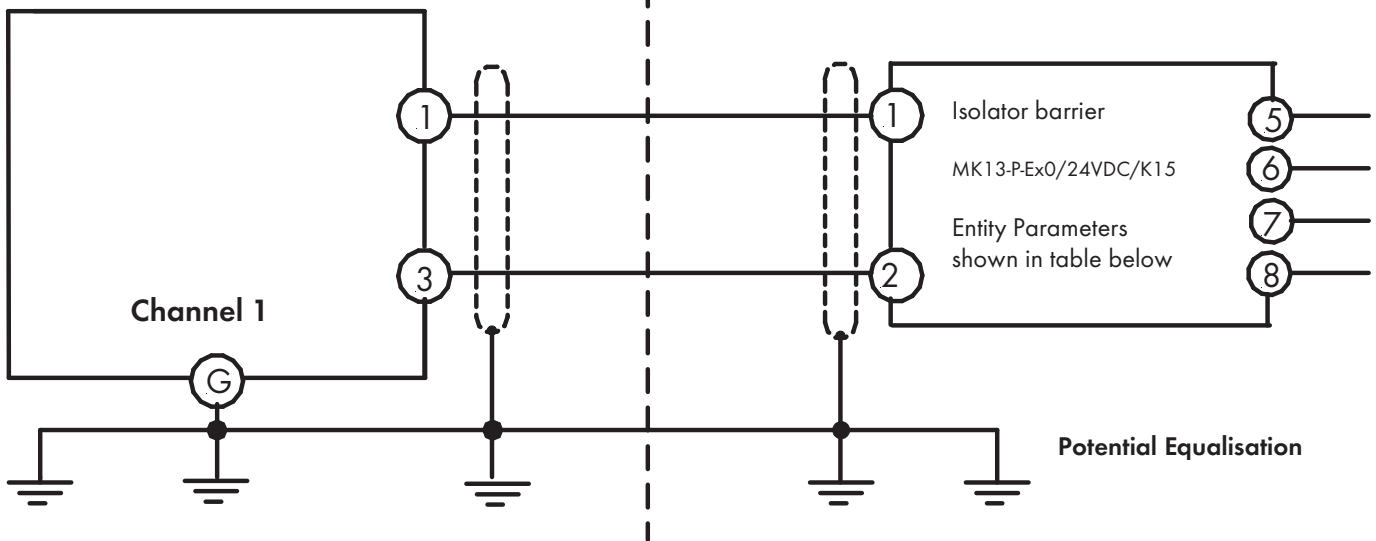

Terminals	Group	C _{cable} (µF)	L _{cable} (mH)
1-2	A/B/IIC	3.3	82
1-2	C/IIB	25.7	296
1-2	D/IIA	209.7	700

Power supply: 24VDC

The Isolator barrier shall be installed in a tool secured enclosure in compliance with the mounting, spacing and segregation requirements of the ultimate application.

1. The installation must be in accordance with the National Electrical Code, NFPA 70, Articles 504 and 505, and ANSI/ISA-RP12.06.01.

2. In order to suppress inductive interference, a connecting cable with the shield bearing on the coupling nut of the four-pole circular plug-in connector must be used during the installation of the flow meter. In explosion prone areas the flow meter is connected to the ground potential. The greatest care must be taken to ensure that between each end of the electrical circuit (i.e. between the explosive area and the non-explosive area) potential equalisation exists.

Drawing No. V 06 6 14 4c

Hazardous (Classified) Location

Class I, Division 1, Groups A, B, C & D T4...T6

Note: T4...T6 temperature code based on 50°C (122°F)

Flow Meter System Series

VHM*-.*****/*.V-L*S**/Ex

Unclassified Location

ASSOCIATED APPARATUS WITH ENTITY PARAMETERS

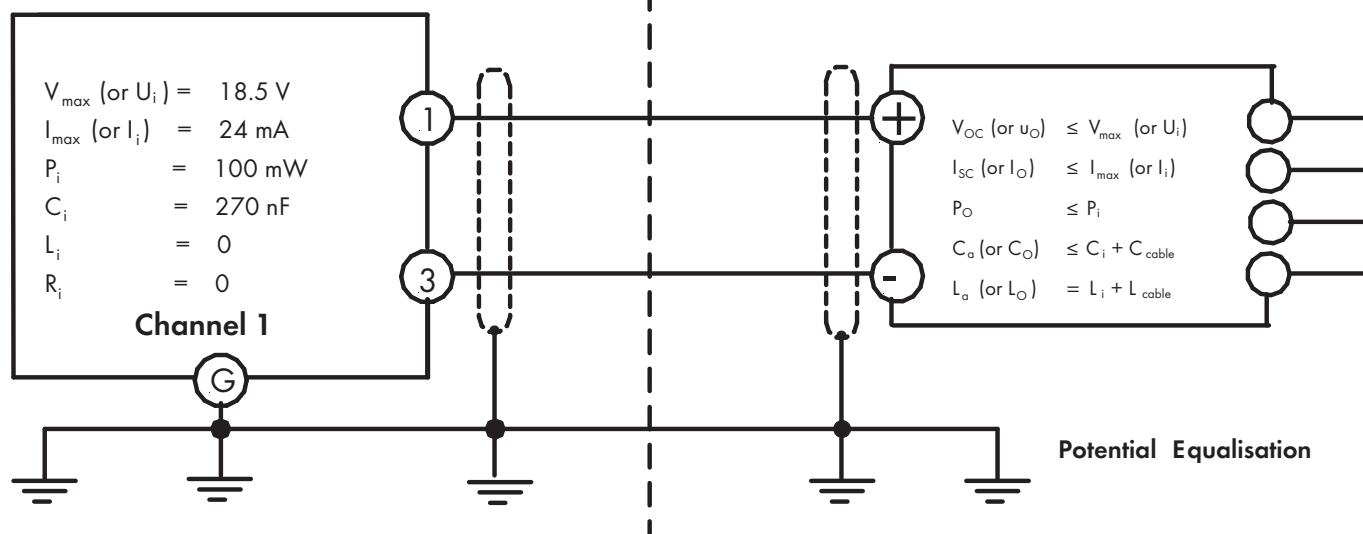

1. The installation must be in accordance with the National Electrical Code, NFPA 70, articles 504 and 505, and ANSI/ISA-RP12.06.01.

2. The flow meter systems Serie VHM*-.*****/*.V-L*S**/Ex is suitable for use in Class I, Division 1 and Zone 0 (AEx ia) applications. If connected to Associated Apparatus the flow meter system VHM*-.*****/*.V-L*S**/Ex may be used in areas classified as zones. If connected to AEx[ib] Associated Apparatus, the flow meter system may only be used in zone 1 or 2 Hazardous (Classified) Locations.

3. In order to suppress inductive interference, a connecting cable with the shield bearing on the coupling nut of the four-pole circular plug-in connect or must be used during the installation of the flow meter. In explosion prone areas the flow meter is connected to the ground potential. The greatest care must be taken to ensure that between each end of the electrical circuit (i.e. between the explosive area and the non-explosive area) potential equalization exists.

Drawing No. V 06 6 08 4b

PREAMPLIFIERS FOR EX-TYPE VHM SERIES

General information

The preamplifiers are supplied in different versions depending on the application. There are single and dual pick-ups available. The basic method used to sense and measure is the same for both versions and is based on the carrier frequency principle.

When a dual pickup is used, you simply double or quadruple the number of pulses depending on the setting. All versions must be operated with the isolation amplifier.

The single pick-up

The single pick-up operates with a carrier frequency oscillator that is modulated whenever a tooth passes by. This modulation is evaluated by the subsequent preamplifier electronics and generates a modulated digital current signal that is amplified and digitized by the isolation

amplifier. The number of pulses is proportional to the volume delivered. The flow rate can then be evaluated from the frequency of this pulse signal.

The dual pick-up

The dual pick-up operates with two independent carrier frequency oscillators that are modulated whenever a tooth passes by. The electronics generates a pulse signal for each modulation. The pulses from both pick-up systems are combined in the subsequent preamplifier electronics and output as a double pulse for each tooth. If necessary, you can select pulse quadrupling by changing a internal jumper, please

note that the flow rate range is reduced with this setting. The output signal from the preamplifier is also a current-modulated pulse signal that is amplified and digitized by the isolation amplifier. The volume of fluid and the flow rate can be evaluated from the number of pulses and the frequency.

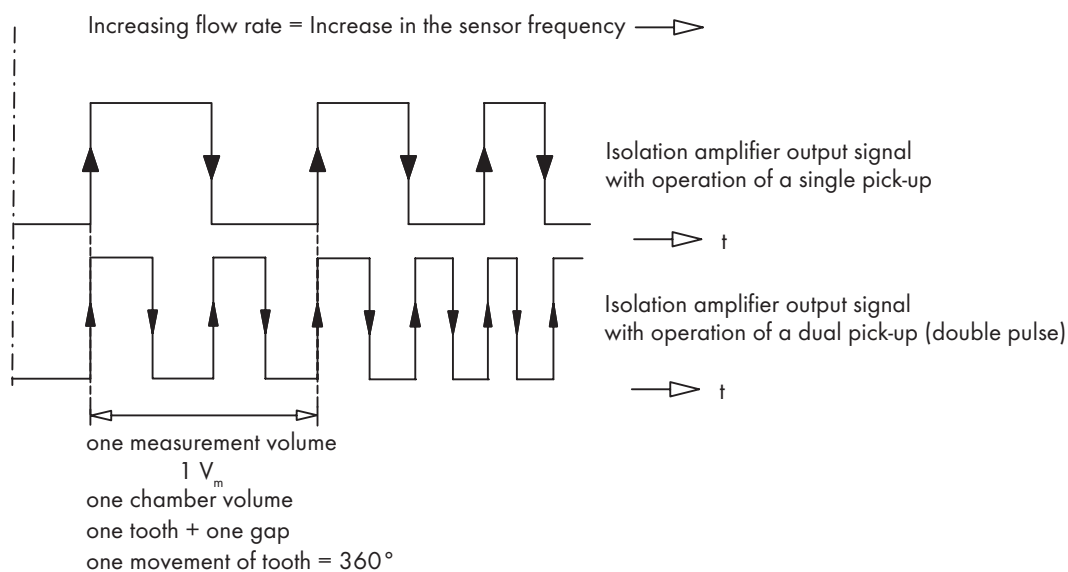
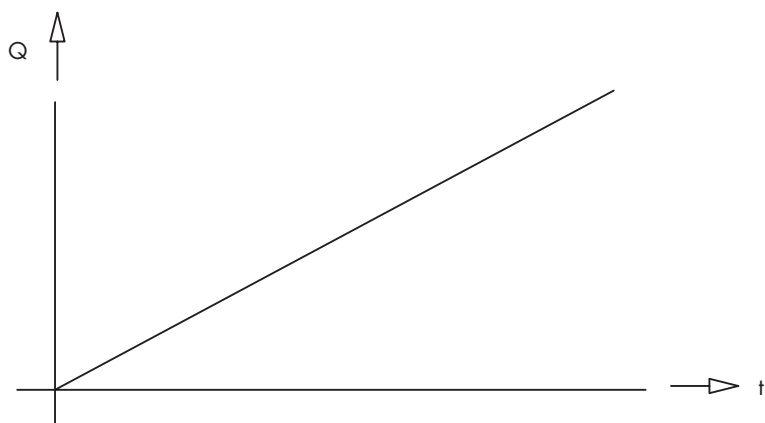

Figure 7: Signal output

APPLICATION WITH DIRECTION DETECTION

If it is necessary to detect the direction of flow, the VHM-flow meter must be operated with two single pick-ups with different carrier frequencies of type VIL*-S**/EX and VTL*-S**/EX. The pick-ups generate two pulse signals with a phase offset of 90°.

Each of the pick-ups is operated with an isolation amplifier. Also it is possible to increase the resolution, when you process the rising and falling edges from both channels (1/4 nm).

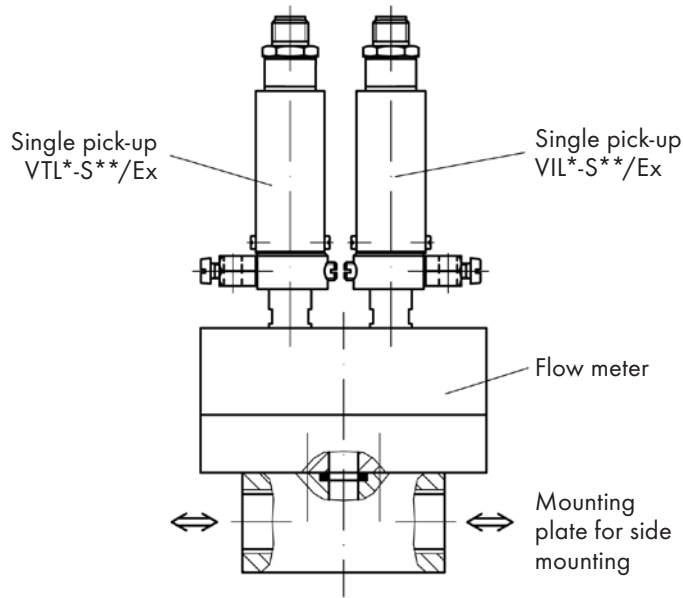

Figure 8: VHM-flow meter with direction detection

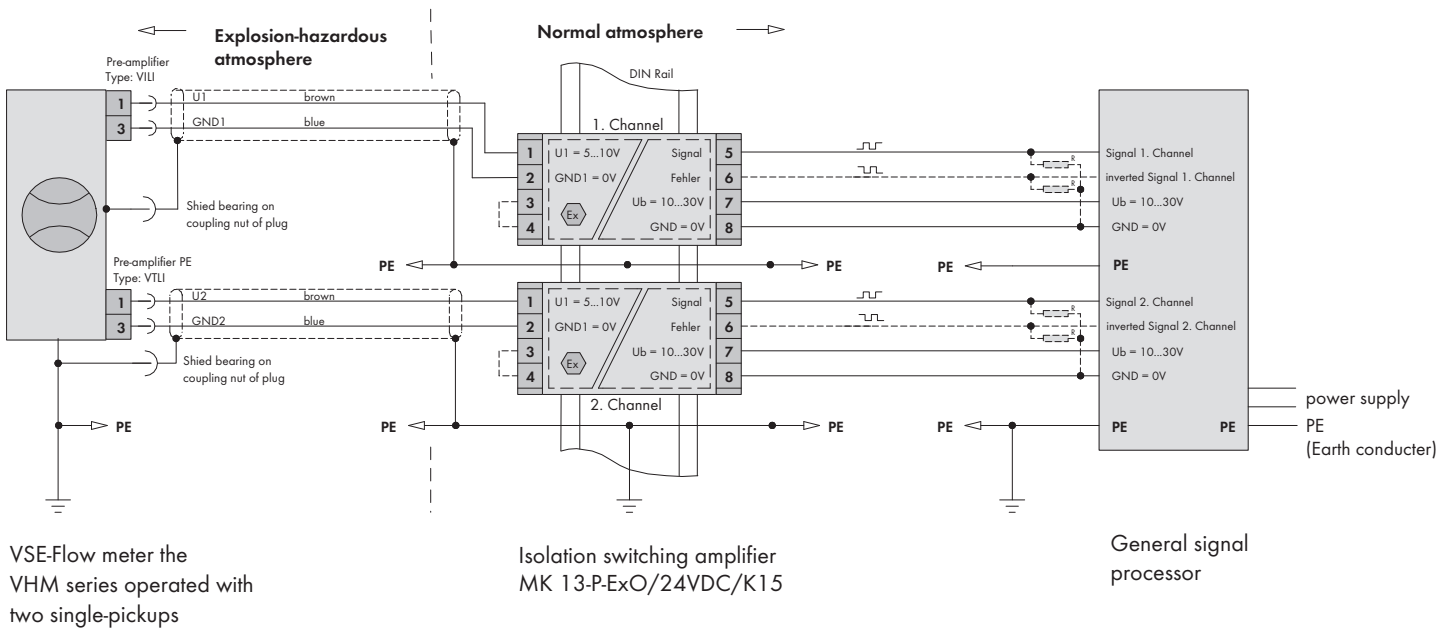

Figure 9: Application with direction detection

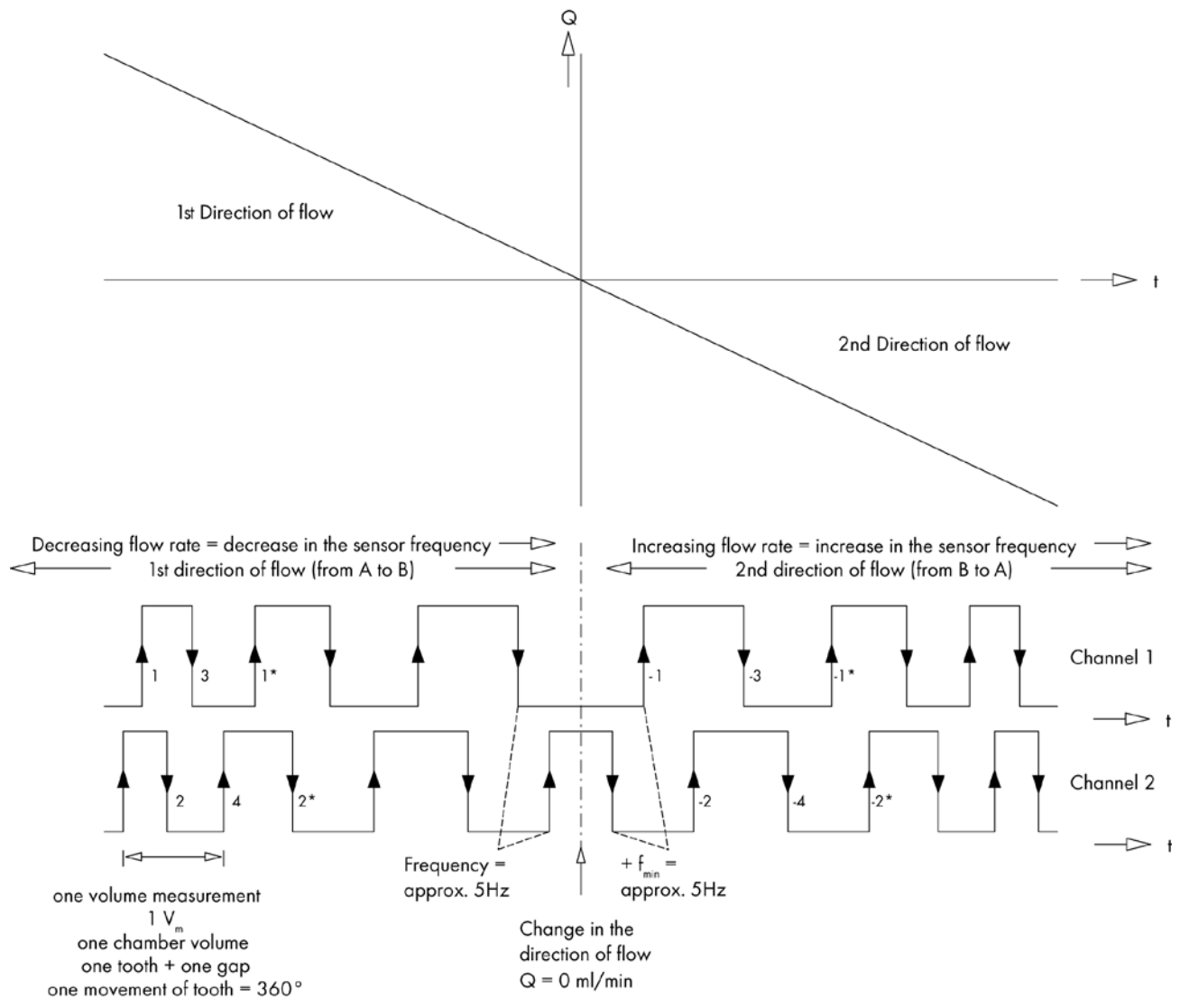

Figure 10: Signal output with two single pick-ups (Ex-type)

SAFETY INSTRUCTIONS FOR INSTALLATION AND OPERATION IN HAZARDOUS AREAS

1. Only qualified personnel, meaning authorized persons with special explosion protection training, are permitted to install explosion-protected equipment and systems!
2. The qualified personnel must have read and understood the installation regulations and the corresponding type Examination Certificates and Declarations of Conformity!
3. Work may only be done on the devices in a de-energized state!
4. Before you operate the flow meter, you must carefully clean and rinse the entire system so that no foreign particles from the installation can get into the measuring unit of the flow meter.
5. The pipes and the flow meter must always be filled in operation so that no gas bubbles can form!
6. Extremely dirty media or foreign particles in the medium can block, damage or even destroy the measuring unit. In these cases you should always install a sufficiently rated filter ahead of the flow meter so that no foreign particles or substances can get into the measuring unit and damage the flow meter.
7. The permissible ambient and media temperatures in the corresponding temperature class may not be exceeded at any time, when operating the flow meter.
8. You may not change or extend the devices in any way, if the modifications were not expressly permitted by the manufacturer. If the preamplifier or isolation amplifier housing is opened, then the explosion protection certification becomes invalid!
9. The VSE flow meters are not authorized for use in areas subject to a dust explosion hazard!
10. To suppress inductive interference, you must use a connection cable in which the shield is seated on the union nut of the four-pin circular connector. In Ex-hazardous areas, the flow meter is connected to a ground potential. You must be extremely certain that there is an equalization of potential between each end of the circuit. The potential equalization of the ground conductor PE must be present throughout the entire area.
11. The operator of the plant must maintain the system in proper operating condition, operate the system properly, monitor it constantly, perform the necessary maintenance and any related work immediately, and follow the relevant safety regulations, when doing so. This procedure, known as continuous monitoring, will eventually be adopted as a new law of the corresponding country.
12. VSE supplies special flow meters from the VHM series, when the flow meter is to be operated in a Ex-hazardous area. These flow meters are authorized for use in Ex-hazardous areas and must always be operated in conjunction with isolated switching amplifiers that guarantee intrinsic safety and are Ex-certified. The intrinsically safe circuits are marked in blue and offer the safety level required for explosion protection!
13. The isolation amplifier must guarantee the "ia/IS" level of intrinsic safety of the signal circuit, and their limit values may not exceed the highest permitted input value of the flow meter.
14. When equipment is connected electrically, a "Verification of Intrinsic Safety" must be performed according to the actual regulations and standards. Even if an intrinsically safe circuit is connected just once to a non-intrinsically safe circuit, then the piece of equipment is not authorized for use anymore as a device with intrinsically safe circuits. This applies to the isolation amplifiers as well as the flow meters. The relevant, applicable regulations apply to the installation of intrinsically safe circuits, the mounting of external connectors, the properties and routing of lines and cables. Cables and terminals with intrinsically safe circuits must be labeled accordingly and must be isolated from non-intrinsically safe circuits or be equipped with appropriate isolation according to the actual standards.
15. The sum of the maximum effective capacitance C_i and inductivity L_i of the flow meter and the four-pin connection cable may not exceed the maximum values $C_0 (C_a)$ and $L_0 (L_a)$ of the corresponding isolation amplifier. Pay attention to the manufacturer's specifications for the connection cable and to the lengths of the cables used.
16. It must be especially observed that the radial thickness of the insulation of a conductor have a minimum thickness of 0.2 mm. The diameter of a finely stranded conductor must not be smaller than 0.1 mm. The ends of the conductor have to be protected against fanning out, e.g. by ferrules.
In addition to this the sheath insulation must be tested in respect of electrostatic charge to ensure a safe use in the intrinsically safe area. The VSE-Ex-cable corresponds to these requirements.
17. It must be especially observed that for the use of devices with two channels there exist two intrinsically safe power circuits in a cable. Here please observe the corresponding regulations and standards (e.g. EN60079-14; part 12.2.2.7/8). An installation firm and protected against damages is always necessary for this kind of operation.
18. When operating or performing maintenance or repairs on the flow meter, the surface of the flow meter housing must be safely protected from impact or sharp edges, tools or other items!
19. The flow meter parts contain shares of aluminum, magnesium, titan and /or zirconium. The generation of impacts and friction, especially between different metals, must be prevented so that the production of sparks is ruled out!
20. When using the flow meters (Ex-Type VHM) in Ex-hazardous areas requiring category 1 equipment, the flow meter is to be installed so that sparks from impact or friction can be ruled out!
21. The marking on the typeplate must stay readable.



MAINTENANCE, SERVICE LIFE AND WARRANTY

Depending on the operating conditions, the service life and therefore the specific properties of the units are limited by wear, corrosion, deposits or ageing. The operator is responsible for regular inspection, maintenance and recalibration. Any observation of a malfunction or damage prohibits

further use. On request, we can provide you with a loan unit for the duration of the overhaul. We recommend an annual check and recalibration. Under normal operating conditions, the service life is 10,000 hours. The warranty period is 12 months.

STORAGE, RETURN AND DISPOSAL

Temporary storage

All VSE flow meters are supplied with sealing plugs and in suitable packaging for all destinations and modes of transport to ensure optimum protection. The flow meters should always be stored in their original foam packaging or transport box. The units must not be exposed to temperatures below -20°C or above $+60^{\circ}\text{C}$ and must be protected from moisture and its effects.

Return

1. The flow meter must be properly cleaned by the customer before being returned to prevent the risk of poisoning/contamination by harmful, explosive and other high-risk pumped media for humans and the environment.
2. If media have been conveyed whose residues with atmospheric humidity lead to corrosion damage or ignite on contact with oxygen, the flow meter must be additionally neutralised and thoroughly cleaned with anhydrous, inert gas to dry.
3. The return of the flow meter must always be accompanied by a fully completed declaration of no objection (see page 40). All applied safety and decontamination measures must be indicated.
4. When returning the flow meter, it must be packed in accordance with the applicable logistics standards and sealed with sealing plugs.

Disposal

VSE actively promotes environmental awareness and has an operational management system that meets the requirements of ISO 9001:2015. The impact on the environment and people should be minimised during the production, storage, transport, use and disposal of our products and solutions.

- Collect rinsing liquid as well as residual liquid and dispose of it in accordance with the statutory provisions and regulations.
- Wear protective clothing and protective mask/+ goggles if necessary.

Materials must be disposed of properly as follows:

- Metal
- Plastics
- Electronic components
- etc.

When disposing of the materials, ensure that the waste-relevant rules and regulations of the respective country of destination are observed!

TECHNICAL DATA FOR THE VHM FLOW METER

Size	Measurement Range l/min	Measured Volume V_m ml/imp.	Frequency Hz	K-factor imp./liter
VHM 01-2	0.01 ... 1	ca. 0.045	ca. 3.7 ... 370.0	ca. 22,200
VHM 02-1	0.05 ... 2	ca. 0.120	ca. 6.9 ... 278.0	ca. 8,800
VHM 02-2	0.10 ... 4	ca. 0.225	ca. 7.4 ... 296.0	ca. 4,400
VHM 02-3	0.40 ... 8	ca. 0.450	ca. 14.8 ... 296.0	ca. 2,200
VHM 03-2	0.50 ... 20	ca. 1.010	ca. 8.25 ... 330.0	ca. 1,000

The exact data can be found in the calibration report.

Measurement accuracy	$\pm 0.5\%$ of the measured value (at viscosities $> 10\text{ mm}^2/\text{s}$) $\pm 1\%$ of the measured value (at viscosities $1 - 10\text{ mm}^2/\text{s}$)
Repeating accuracy	$\pm 0.5\%$ under the same operating conditions
Materials	Gear housing: stainless steel 1.4404 Gears: stainless steel 1.4462 Gear bearings: tungsten carbide Pre-amplifier housing: stainless steel 1.4305 or aluminum
Gear bearings	Sleeve bushing, ball bearings (optional)
Seals	FEP with FPM core (standard) or PTFE
Max. operating pressure	250 bar / 3600 psi
Medium temperature (Ex-type)	$-20^{\circ}\text{C} \dots +80^{\circ}\text{C}$ ($-4^{\circ}\text{F} \dots 176^{\circ}\text{F}$)
Ambient temperature	$-20^{\circ}\text{C} \dots +50^{\circ}\text{C}$ ($-4^{\circ}\text{F} \dots 122^{\circ}\text{F}$)
Viscosity range	1 ... 20,000 mm^2/s
Installation position	Any
Direction of flow	See the direction of the arrow on the flow meter
Mounting	On the mounting plate with piping connections or as a piping system (custom version).

DIMENSIONS FOR VHM FLOW METERS

VHM 01/02

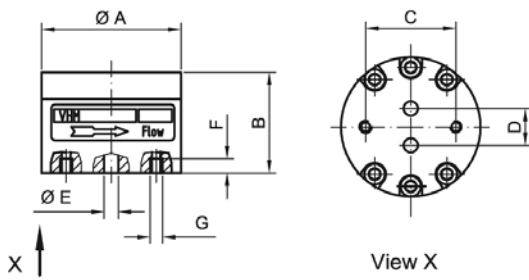

VHM 03

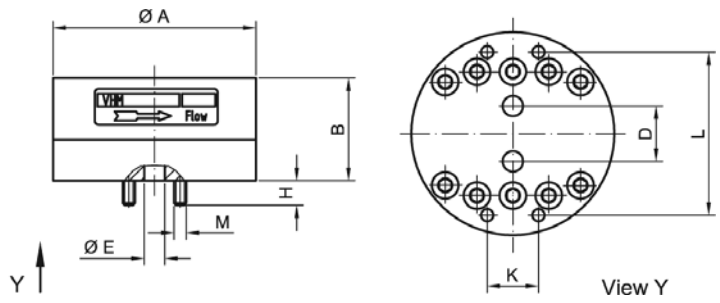

Type	$\varnothing A$	B	C	D	$\varnothing E$	F	G	K	L	M	H	Weight kg
VHM 01-2	68	29	44	12	4	6	M6					0.750
VHM 02-1	68	29	44	18	6	6	M6					0.740
VHM 02-2	68	34	44	18	6	6	M6					0.860
VHM 02-3	68	43	44	18	6	6	M6					1.075
VHM 03-2	99	50		27	10			25	81	M6	12	2.700

Dimensions in mm

DIMENSIONS OF THE AHM MOUNTING PLATE

AHM 01/02 for side mounting

AHM 03 for side-mounting

Position of the cable connections

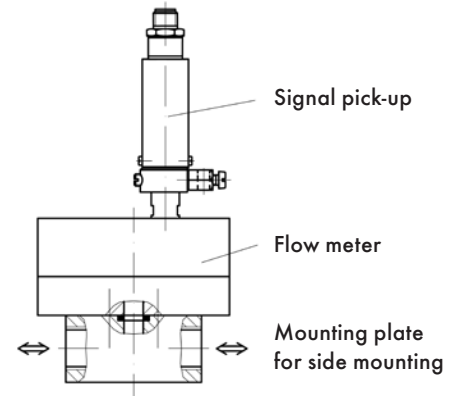
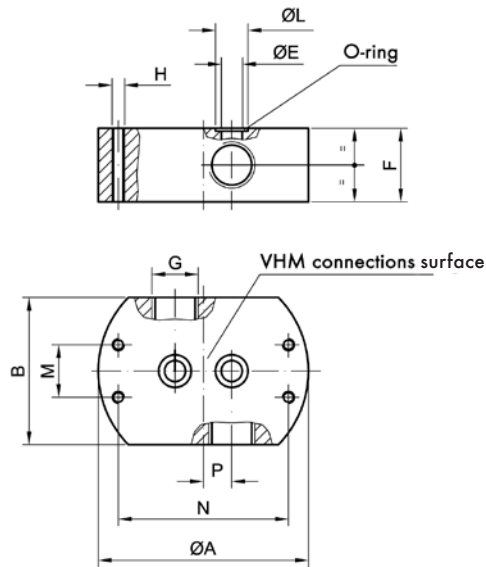
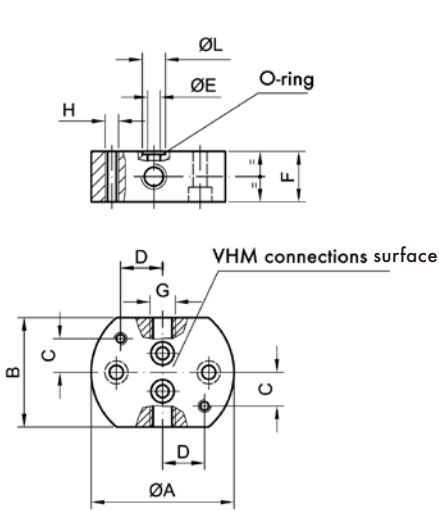

Permissible Size VHM	G	$\varnothing A$	B	C	D	$\varnothing E$	F	H	$\varnothing L$	M	N	P	O-ring
01-1	G 1/8"	68	52	16	20	4	24	M6	9,4				6.07 x 1.78
	G 1/4"												
02 - 1, 2, 3	G 1/8"	68	52	16	20	6	24	M6	11				7.65 x 1.78
	G 1/4"												
	1/8" NPT												
	1/4" NPT												
03	G 3/8"	100	70			10	35	M6	15.5	25	81	13,5	12.42 x 1.78
	G 1/2"												
	3/8" NPT												
	1/2" NPT												

Dimensions in mm

TYPE CODE FOR VHM, AHM

VHM flow meter

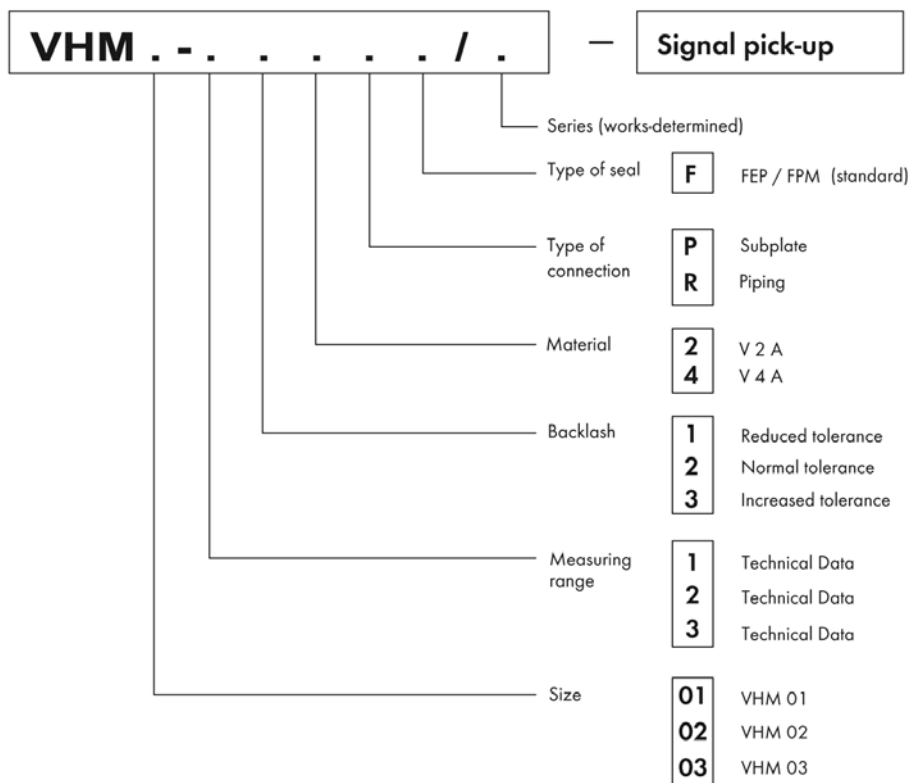

AHM mounting plate

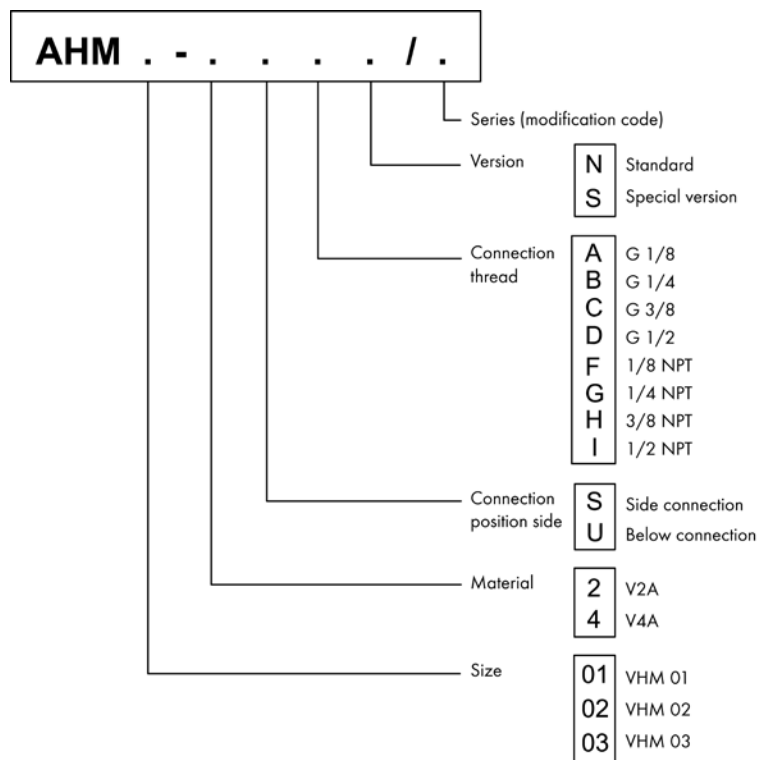

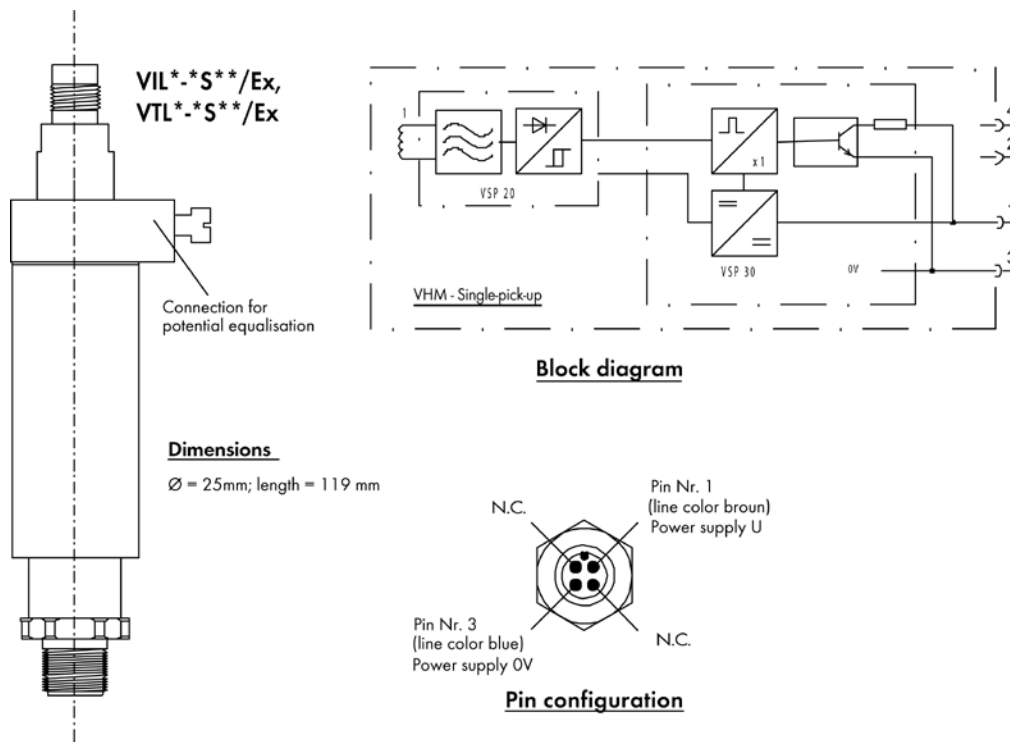

Electronic Connection data for VIL^{*}-S^{}/Ex, VTL^{*}-S^{**}/Ex**

EC-Type Examination Certificate	BVS 05 ATEX E 121
Type Code	VIL [*] -S ^{**} /Ex; VTL [*] -S ^{**} /Ex
Certification	Ex II 1G Ex ia IIC T4...T6 IS CL1; Div 1; GRPS A,B,C,D; T4...T6
Nominal voltage	8 ... 10V
Switching currents	$I_{Low} < 2.7\text{ mA}$; $I_{High} > 3.7\text{ mA}$
Signal frequency	5 Hz – ca. 1000 Hz (*)
Max. input voltage	$U_i \leq 24.3\text{ V}$
Max. input current	$I_i \leq 36.5\text{ mA}$
Max. power consumption	$P_i \leq 110\text{ mW}$
Internal resistance	$R_i \leq 0$
Internal capacitance	$C_i \leq 120\text{ nF}$
Additional equipment	isolated switching amplifier MK13-P-Ex0/24VDC/K15

(*) Depends on the size of the flow meter

Type Plates

VIL^{*}-S^{}/Ex, VTL^{*}-S^{**}/Ex**

Type: VILx - x S1 x / Ex
 Serial-No.: XXX Baujahr: XX/XX
BVS 05 ATEX E 121 X
 Ex II 1G Ex ia IIC T6...T4
 T6...T4: -20°C...80°C $U_i = 24,3\text{V}$
 Tamb: -20°C...50°C $I_i = 36,5\text{mA}$
 $P_i = 110\text{mW}$
 $C_i = 120\text{nF}$
CE 0158
VSE GmbH D-58809 Neuenrade

Type: VILI - 1S10 / Ex
 Serial-No.: *** Mfg. date: ***
IS CL1 Div1 GRPS A, B, C, D, T4,..T6
 ENTITY Parameters :
 $U_i = 24,3\text{V}$ $I_i = 36,5\text{mA}$ $P_i = 110\text{mW}$ $C_i = 120\text{nF}$
 T4 .. T6 @ Ta =
 -20°C (-4°F) to 50°C (122°F)
 CTL. DWD. V06 6 08 4b
F.M. APPROVED
VSE GmbH 58809 Neuenrade Germany

Housing data for VIL^{*}-S^{}/Ex, VTL^{*}-S^{**}/Ex**

Dimensions	$\varnothing = 25\text{ mm}$; l = 119 mm
Protection class	IP 54
Material	Stainless steel 1.4305
Weight	115 g
Max. surface temperature	T4 ... T6 = 80°C (176°F)
Ambient temperature	-20°C ... 50°C (-4°F ... 122°F)
Seals	FPM
Coil encapsulating	2K-Epoxy
Connector	VSE Standard Connector M12

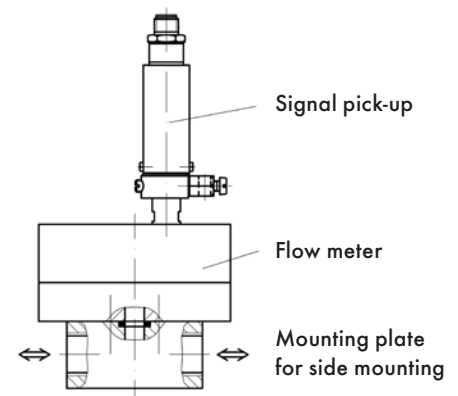

TECHNICAL DATA FOR SINGLE PICK-UPS VEL^{*}-*S^{**}/EX

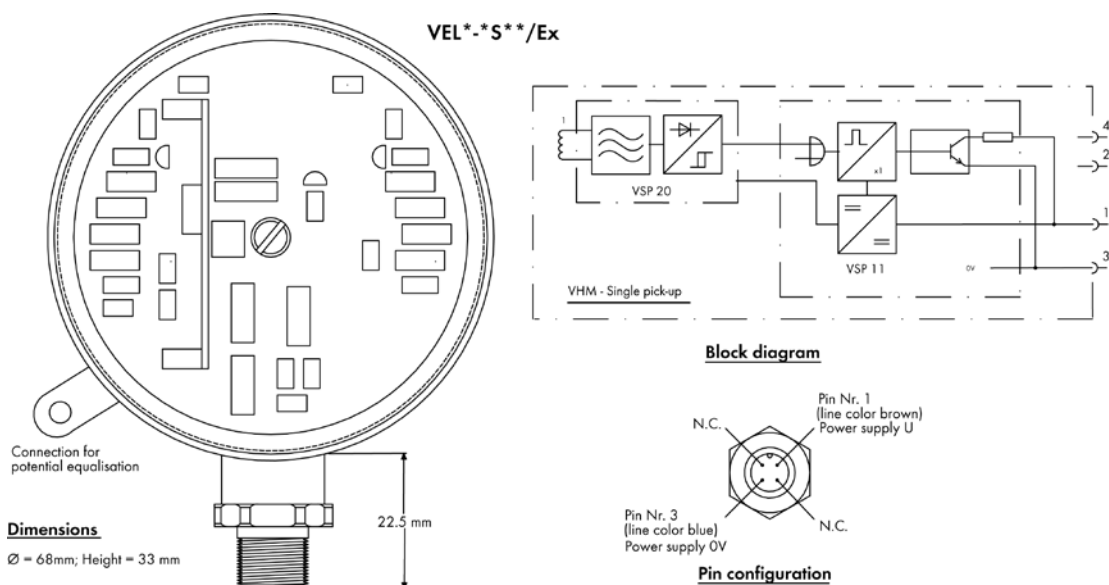

Electronic connection data for VEL^{*}-*S^{**}/Ex

EC-Type Examination Certificate	BVS 05 ATEX E 121
Type Code	VEL [*] -*S ^{**} /Ex
Certification	II 1G Ex ia IIC T4...T6 IS CL1; Div 1; GRPS A,B,C,D; T4...T6
Nominal voltage	8 ... 10 V
Switching currents	$I_{Low} < 2.7 \text{ mA}$; $I_{High} > 3.7 \text{ mA}$
Signal frequency	5 Hz - 500 Hz
Max. input voltage	$U_i \leq 18.7 \text{ V}$
Max. input current	$I_i \leq 36.5 \text{ mA}$
Max. power consumption	$P_i \leq 110 \text{ mW}$
Internal resistance	$R_i \leq 0$
Internal inductance	$L_i \leq 0$
Internal capacitance	$C_i \leq 270 \text{ nF}$
Additional equipment	isolated switching amplifier MK13-P-Ex0/24VDC/K15

Type Plates VEL^{*}-*S^{**}/Ex



Housing Data VEL^{*}-*S^{**}/Ex

Dimensions	Ø = 68 mm; h = 33 mm
Protection class	IP 54
Material	Anodized blue aluminum Stainless steel 1.4305 (coil)
Weight	165 g
Max. surface temperature	T4 ... T6 = 80°C (176°F)
Ambient temperature	-20°C ... 50°C (-4°F ... 122°F)
Seals	FPM
Coil encapsulating	2K-Epoxy
Connector	VSE Standard Connector M12

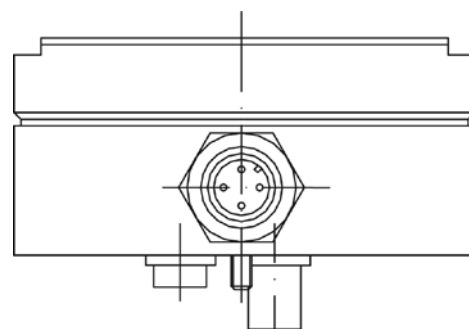

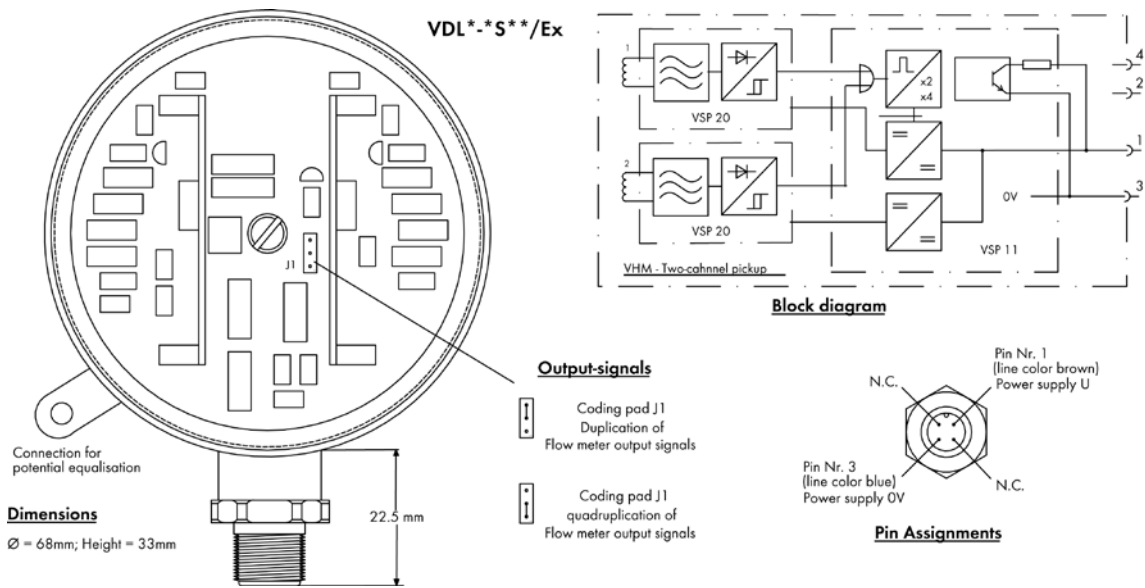

Electronic connection data for VDL*-S**/Ex

EC-Type Examination Certificate	BVS 05 ATEX E 121
Type Code	VDL*-S**/Ex
Certification	Ex II 1G Ex ia IIC T4...T6 IS CL1; Div 1; GRPS A,B,C,D; T4...T6
Nominal voltage	8 ... 10 V
Switching currents	$I_{Low} < 2.7 \text{ mA}$; $I_{High} > 3.7 \text{ mA}$
Signal frequency	5 Hz - 500 Hz (Pulse doubling) 10 Hz - 500 Hz (Pulse quadrupling) (*)
Max. input voltage	$U_i \leq 18.7 \text{ V}$
Max. input current	$I_i \leq 36.5 \text{ mA}$
Max. power consumption	$P_i \leq 110 \text{ mW}$
Internal resistance	$R_i \leq 0$
Internal inductance	$L_i \leq 0$
Internal capacitance	$C_i \leq 270 \text{ nF}$
Additional equipment	isolated switching amplifier MK13-P-Ex0/24VDC/K15

(*) Note that the restricted flow rate measurement range due to the quadrupling of the pulse

Type Plates VDL*-S**/Ex



Housing data VDL*-S**/Ex

Dimensions	Ø = 68 mm; h = 33 mm
Protection class	IP 54
Material	Anodized blue aluminum Stainless steel 1.4305 (coil)
Weight	165 g
Max. surface temperature	T4 ... T6 = 80°C (176°F)
Ambient temperature	-20°C ... 50°C (-4°F ... 122°F)
Seals	FPM
Coil encapsulating	2K-Epoxy
Connector	VSE Standard Connector M12

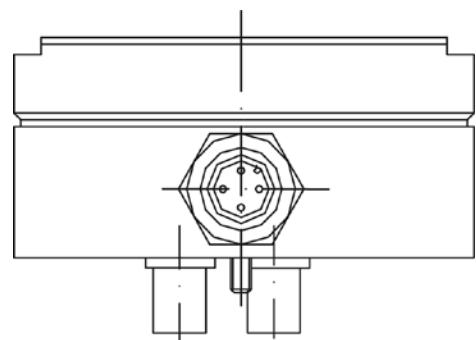

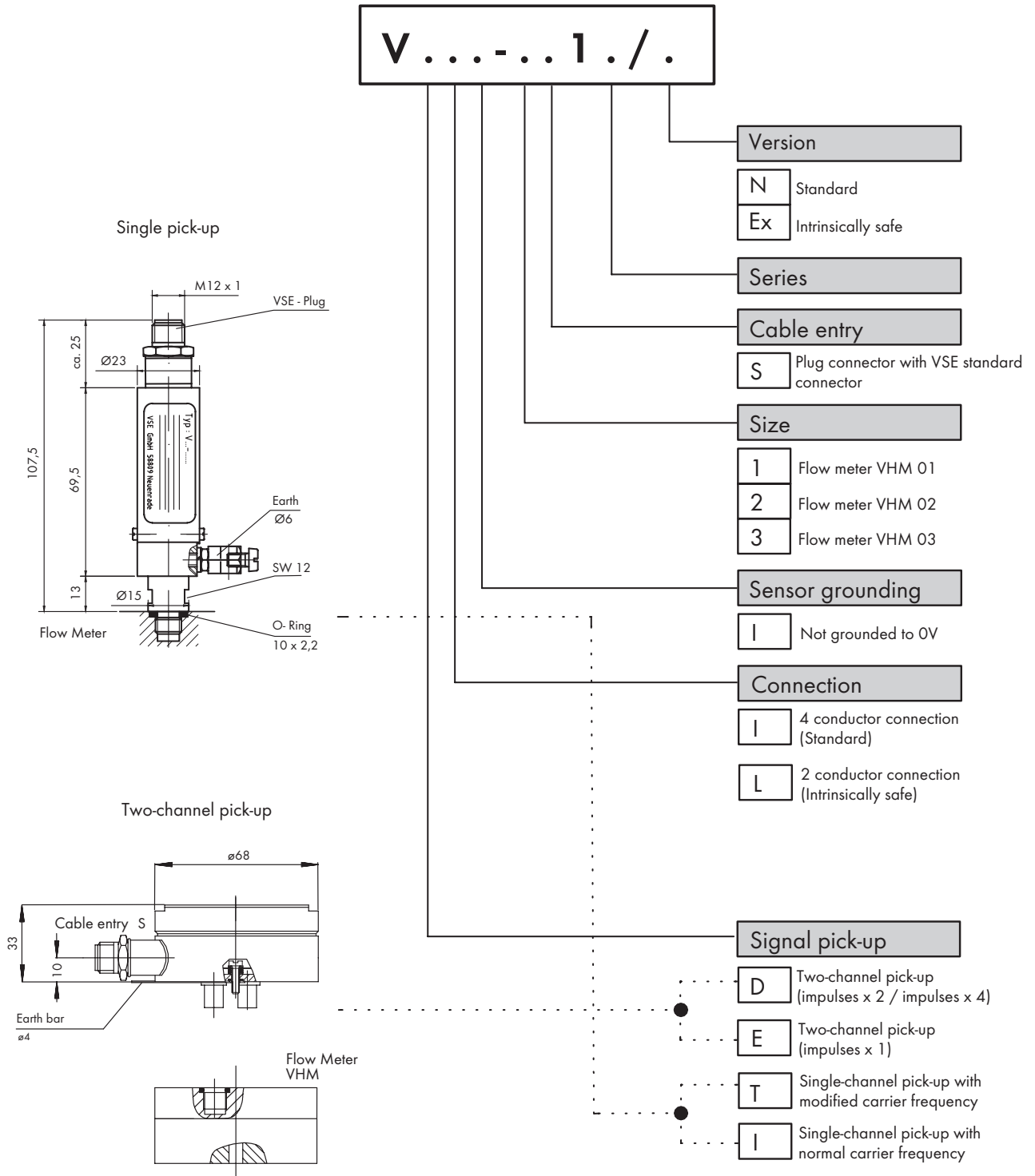

* With the VDB series... (fiber-optic output), the signal can only be doubled (pulse x 2)

TECHNICAL DATA FOR THE VHM TITAN

Size	Measurement range l/min	Measured Volume V_m ml/imp.	Frequency Hz	K-factor imp./liter
VHM 01-1_T1	0.01 ... 1	approx. 0.04	approx. 5 ... 417	approx. 24,000
VHM 02-2_T1	0.05 ... 2	approx. 0.11	approx. 7.6 ... 303	approx. 8,800

The exact data can be found in the calibration report.

Measurement accuracy	± 0.5 % of the measured value (at viscosities > 10mm ² /s) ± 1 % of the measured value (at viscosities 1 - 10mm ² /s)
Repeating accuracy	± 0.5 % under the same operating conditions
Materials	Gear housing: Titanium Gears: Stainless steel 1.4462 Gear bearings: tungsten carbide Preamplifier housing: Aluminum (Al Mg Si 1) EN AW-6082
Gear bearings	Sleeve bushing
Max. operating pressure	10 bar / 145 psi
Medium temperature (Ex-type)	-20 ... + 80 °C (-4 °F ... 176 °F)
Ambient temperature	-20 ... + 50 °C (-4 °F ... 122 °F)
Viscosity range	1 ... 20,000 mm ² /s
Installation position	Any
Direction of flow	See the direction of the arrow on the flow meter
Installation	Block mounting
Protection class	IP 54

DIMENSIONS FOR VHM TITAN

Flow meter with preamplifier

VHM 01-22TS1/1. + V.L. - 01S00/.

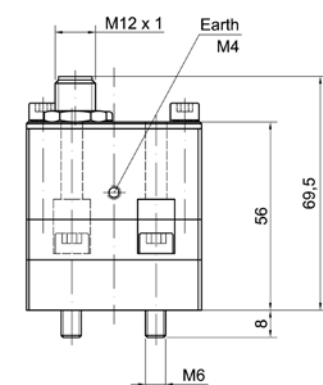

Preamplifier

VR11 - 01S00 / N Standard

VR11 - 01S00 / Ex intrinsically safe

VW11 - 01S00 / N Standard

VW11 - 01S00 / Ex intrinsically safe

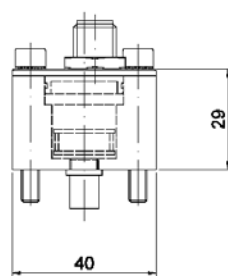

Flow meter

VHM - 01-22TS1/1

N Standard

S Special shaft

D D-Shaft

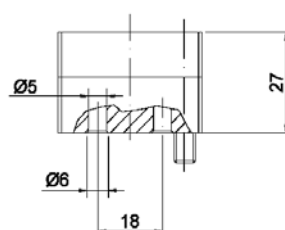

Flow meter with preamplifier
VHM 02-12TS13/1. + V.L. - 02S00/.

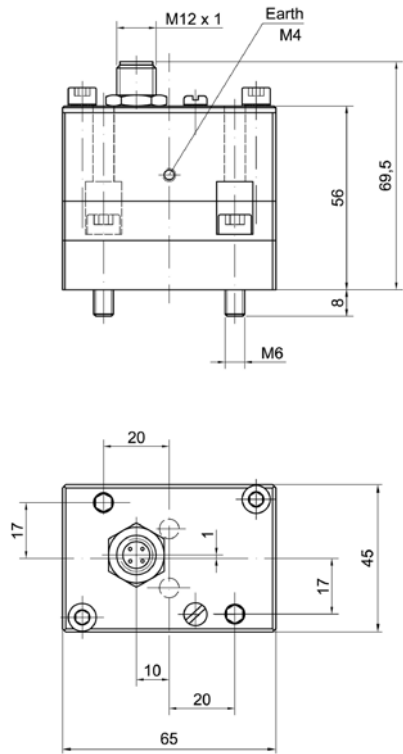

Preamplifier

- VRII - 02S00 / N** Standard
- VRLI - 02S00 / Ex** intrinsically safe
- VWII - 02S00 / N** Standard
- VWLI - 02S00 / Ex** intrinsically safe

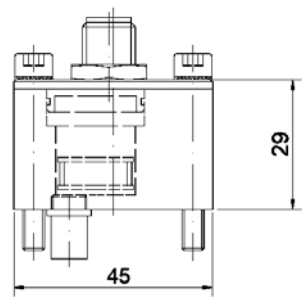

Flow meter

- VHM - 02-12TS13/1 N** Standard
- S** Special shaft
- D** D-Shaft

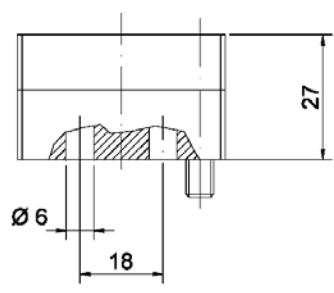

TYPE CODE VHM TITAN
Flow Meter VHM Titan

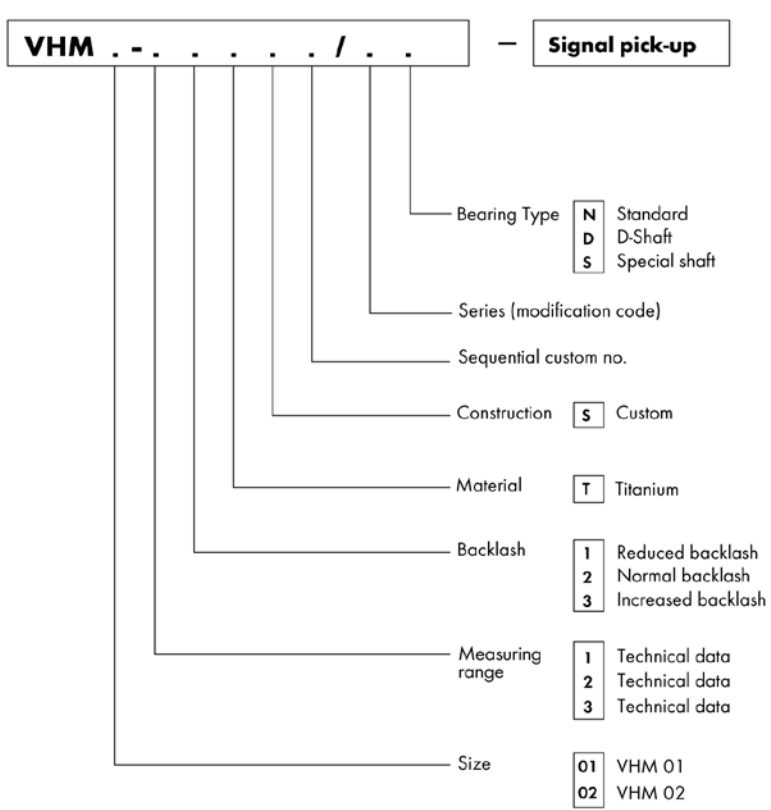

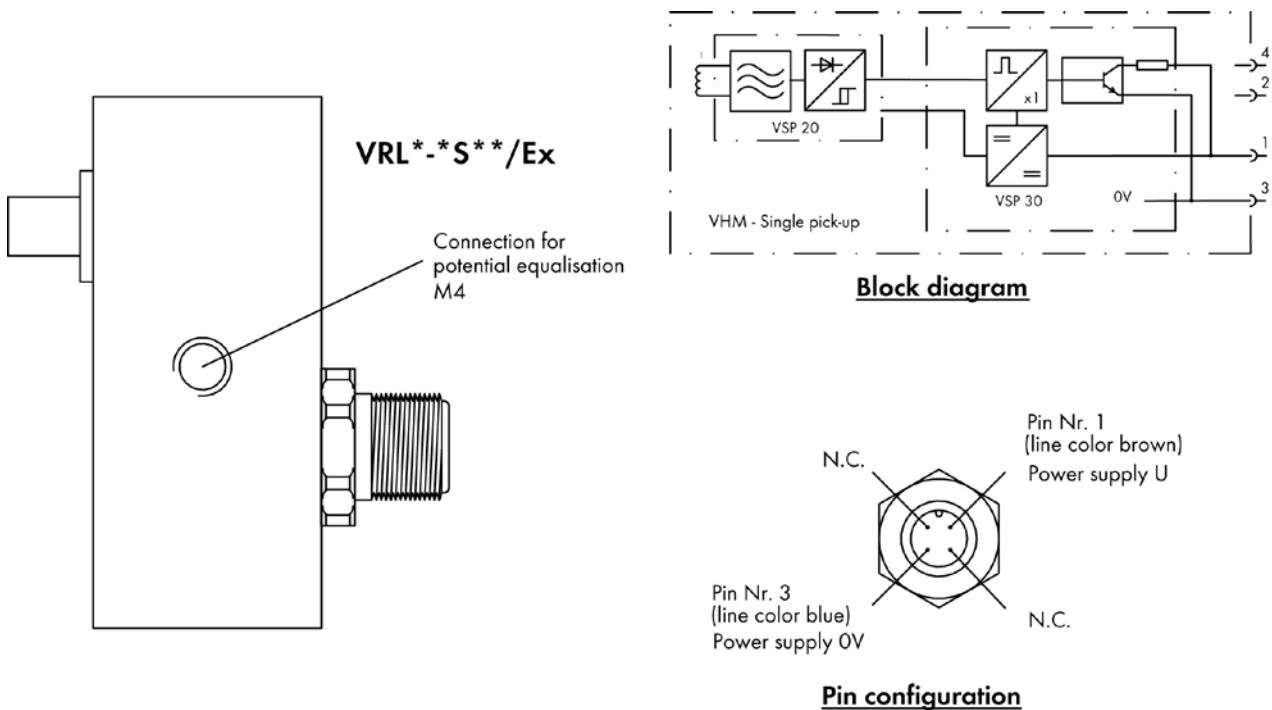

Electronic connection data for VRL^{*}-*S^{**}/EX; VWL^{*}-*S^{**}/EX for VHM Titan

EC-Type Examination Certificate	BVS 05 ATEX E 121
Type Code	VRL [*] -*S ^{**} /EX; VTL [*] -*S ^{**}
Certification	II 1G EEx ia IIC T4...T6 IS CL1; Div 1; GRPS A,B,C,D; T4...T6
Nominal voltage	8 ... 10V
Switching currents	$I_{Low} < 2.7 \text{ mA}$; $I_{High} > 3.7 \text{ mA}$
Signal frequency	6 Hz - 500 Hz
Max. input voltage	$U_i \leq 24.3 \text{ V}$
Max. input current	$I_i \leq 36.5 \text{ mA}$
Max. power consumption	$P_i \leq 110 \text{ mW}$
Internal resistance	$R_i \leq 0$
Internal inductance	$L_i \leq 0$
Internal capacitance	$C \leq 270 \text{ nF}$
Additional equipment	isolated switching amplifier MK13-P-Ex0/24VDC/K15

Housing data for VRL*-S/Ex; VWL*-S**/Ex for VHM Titan**

Dimensions	See the section "Dimensions for VHM Titan"
Protection class	IP 54
Material	(Al Mg Si 1) EN AW-6082
Weight	125 g
Max. surface temperature	T4 ... T6 = 80°C (176°F)
Ambient temperature	-20°C ... 50°C (-4°F ... 122°F)
Seals	FPM
Coil encapsulating	2K-Epoxy
Connector	VSE Standard Connector M12

Type plates for VRL*-S/Ex; VWL*-S**/Ex for VHM Titan**

 <p>D - 58809 Neuenrade Type: VRL*-S1*/Ex Serial-Nr.: *** Baujahr : **/**</p>	<p>BVS 05 ATEX E 121X</p> <p>II 1 G Ex ia II C T6 ... T4</p> <p>Ui = 24,3V li = 36,5mA Pi = 110mW Ri = 0 Li = 0 Ci = 120nF CE 0158</p> <p>T6...T4: -20°C...+80°C Tamb: -20°C...+50°C</p>	 <p>58809 Neuenrade Germany Type: VRL*-S1*/Ex FM Serial-No.: *** Mfg. Date : **/**</p>	<p>IS CL1 Div1 GRPS A, B, C, D, T4...T6</p> <p>ENTITY Parameters: Ui = 24,3V li = 36,5mA Pi = 110mW Ri = 0 Li = 0 Ci = 120nF</p> <p>T6...T4 @ Ta = -20°C (-4°F)...+80°C (122°F)</p> <p>CTL. DWD. V06 6 08 4b</p> 
--	---	--	---

TYPE CODE – SIGNAL PICK-UP FOR VHM TITAN

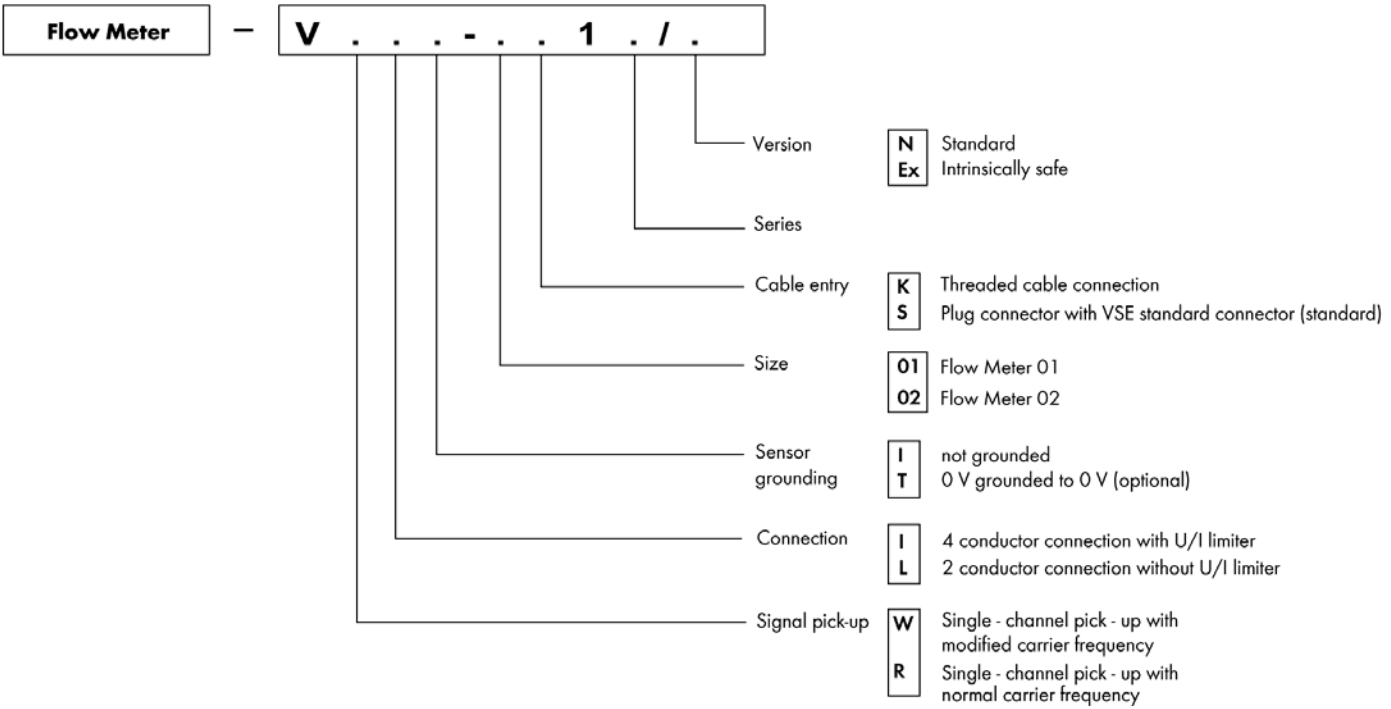

WIRING DIAGRAM WITH ISOLATED SWITCHING AMPLIFIER

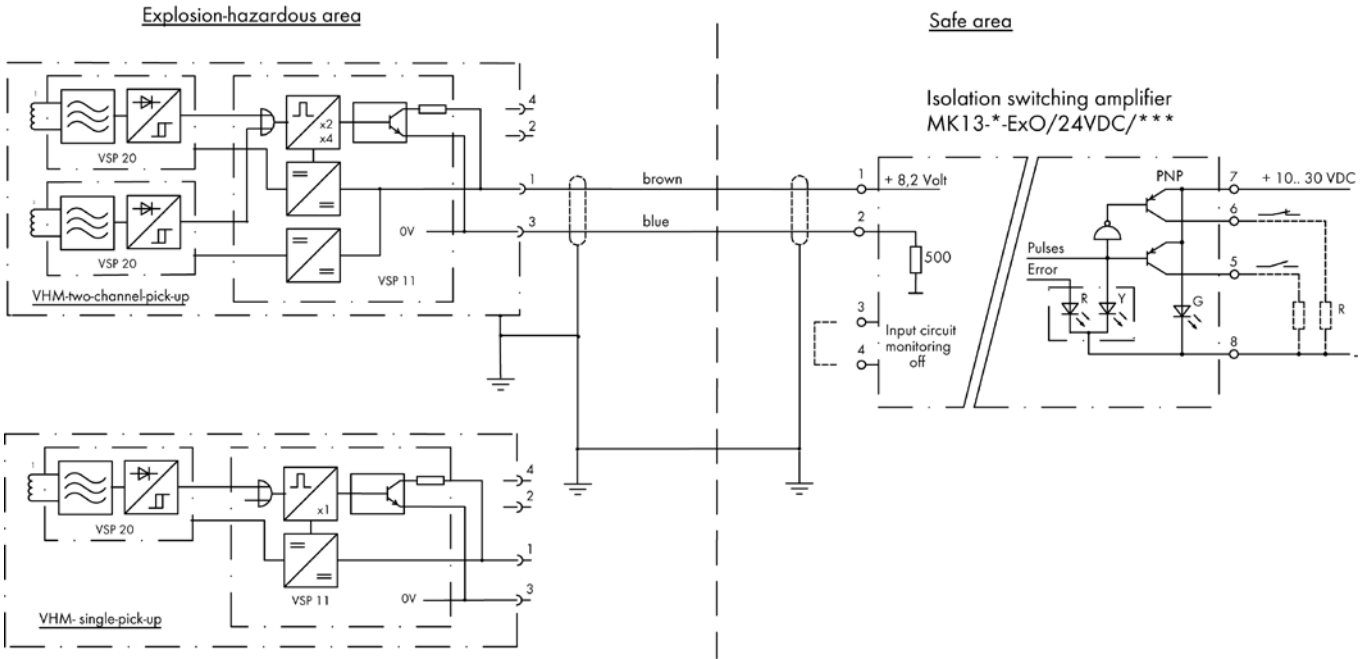

MEDIA AND AMBIENT TEMPERATURES

Temperature class: T4 ... T6
 Media temperature: -20°C (-4°F) ... max. permissible 80°C (176°F)
 Ambient temperature: -20°C (-4°F) ... max. permissible 50°C (122°F)

FLOW METER LABELS AND CERTIFICATIONS

Name and address of the manufacturer: **VSE Volumentchnik GmbH
 Hönnestraße 49
 58809 Neuenrade / Germany**









CE marking: **CE 0158**

Type designation: **V *L*-*S**/Ex**

Marking according to ATEX: **Ex II 1G Ex ia IIC T4...T6**

Marking according to NEC: **F M APPROVED IS CL1 Div 1 GRPS A, B, C, D T4 ... T6**

SUMMARY OF THE SAFETY-RELATED TECHNICAL DATA

SINGLE PICK-UP Type: VIL [*] -S ^{**} /Ex, VTL [*] -S ^{**} /Ex	SINGLE PICK-UP Type: VEL [*] -S ^{**} /Ex	DUAL PICK-UP Type: VDL [*] -S ^{**} /Ex	SINGLE PICK-UP FOR VHM TITAN Typ: VRL [*] -S ^{**} /Ex
BVS 05 ATEX E 121	BVS 05 ATEX E 121	BVS 05 ATEX E 121	BVS 05 ATEX E 121
 II 1G Ex ia IIC T4...T6  IS CL1; Div 1; GRPS A,B,C,D; T4...T6	 II 1G Ex ia IIC T4...T6  IS CL1; Div 1; GRPS A,B,C,D; T4...T6	 II 1G Ex ia IIC T4...T6  IS CL1; Div 1; GRPS A,B,C,D; T4...T6	 II 1G Ex ia IIC T4...T6  IS CL1; Div 1; GRPS A,B,C,D; T4...T6
$U_i = 24.3 \text{ V}$	$U_i = 18.7 \text{ V}$	$U_i = 18.7 \text{ V}$	$U_i = 24.3 \text{ V}$
$I_i = 36.5 \text{ mA}$	$I_i = 36.5 \text{ mA}$	$I_i = 36.5 \text{ mA}$	$I_i = 36.5 \text{ mA}$
$P_i = 110 \text{ mW}$	$P_i = 110 \text{ mW}$	$P_i = 110 \text{ mW}$	$P_i = 110 \text{ mW}$
$R_i = 0$	$R_i = 0$	$R_i = 0$	$R_i = 0$
$L_i = 0$	$L_i = 0$	$L_i = 0$	$L_i = 0$
$C_i = 0.12 \text{ }\mu\text{F}$	$C_i = 0.27 \text{ }\mu\text{F}$	$C_i = 0.27 \text{ }\mu\text{F}$	$C_i = 0.12 \text{ }\mu\text{F}$
Temperature class	T4 ... T6		
Max. media temperature	$-20^\circ\text{C} (-4^\circ\text{F}) \geq T_{\text{Med}} \geq 80^\circ\text{C} (176^\circ\text{F})$		
Max. ambient temperature	$-20^\circ\text{C} (-4^\circ\text{F}) \geq T_{\text{amb}} \geq 50^\circ\text{C} (122^\circ\text{F})$		

VSE Connection Cable, blue RAL 5015

PUR, shielded 2 x 0.34 mm²

$R = 0.053 \text{ }\Omega/\text{m}$

$L = 0.76 \text{ }\mu\text{H}/\text{m} \text{ (x)}$ (x)

CA-A = 60 pF/m (x) (x)

CA-S = 120 pF/m (x) (x)

[(x) = Measured at 1000 Hz]

Isolated Switching Amplifier

Typ: MK13-P-Ex0/24VDC/K15

Please refer to the separately enclosed datasheet



Translation

EC-Type Examination Certificate

(2) **- Directive 94/9/EC -
Equipment and protective systems intended for use
in potentially explosive atmospheres**

(3) **BVS 05 ATEX E 121**

(4) **Equipment: Flow sensor type VHM*-*****/*-V*L*-*S**/Ex**

(5) **Manufacturer: VSE Volumentechnik GmbH**

(6) **Address: 58809 Neuenrade, Germany**

(7) The design and construction of this equipment and any acceptable variation thereto are specified in the schedule to this type examination certificate.

(8) The certification body of EXAM BBG Prüf- und Zertifizier GmbH, notified body no. 0158 in accordance with Article 9 of the Directive 94/9/EC of the European Parliament and the Council of 23 March 1994, certifies that this equipment has been found to comply with the Essential Health and Safety Requirements relating to the design and construction of equipment and protective systems intended for use in potentially explosive atmospheres, given in Annex II to the Directive.
The examination and test results are recorded in the test and assessment report BVS PP 05.2088 EG.

(9) The Essential Health and Safety Requirements are assured by compliance with:
EN 50014:1997+A1-A2 General requirements
EN 50020:2002 Intrinsic safety 'i'
EN 50284:1999 Equipment Group II Category 1G

(10) If the sign "X" is placed after the certificate number, it indicates that the equipment is subject to special conditions for safe use specified in the schedule to this certificate.

(11) This EC-Type Examination Certificate relates only to the design, examination and tests of the specified equipment in accordance to Directive 94/9/EC.
Further requirements of the Directive apply to the manufacturing process and supply of this equipment. These are not covered by this certificate

(12) The marking of the equipment shall include the following:

II 1G EEx ia IIC T6

EXAM BBG Prüf- und Zertifizier GmbH

Bochum, dated 22. August 2005

Signed: Dr. Eickhoff

Signed: Dr. Arnold

Certification body

Special services unit



(13) Appendix to

(14) EC-Type Examination Certificate

BVS 05 ATEX E 121

(15) 15.1 Subject and type

Flow sensor type VHM*-*****/*-V*L*-*S**/Ex

Instead of the *** in the complete denomination letters and numerals will be inserted which characterize variations.

15.2 Description

The flow sensor is used for measurement of flow resp. mass flow and volume resp. mass in liquids.

The electrical components of the sensor are mounted inside an titan enclosure (VHM*-*****/*-VRL*-*S**/Ex) or a stainless steel enclosure (type VHM*-*****/*-VEL*-*S**/Ex, VHM*-*****/*-VDL*-*S**/Ex, VHM*-*****/*-VIL*-*S**/Ex and VHM*-*****/*-VTL*-*S**/Ex).

The electrical connection is done by a connector.

15.3 Parameters

15.3.1 Type VHM*-*****/*-VEL*-*S**/Ex and Typ VHM*-*****/*-VDL*-*S**/Ex

Voltage	Ui	DC	18,7	V
Current	Ii		36,5	mA
Power	Pi		110	mW
Effective internal capacitance	Ci		0,27	µF
Effective internal inductance	Li			negligible

4.2 Typ VHM*-*****/*-VIL*-*S**/Ex, Typ VHM*-*****/*-VTL*-*S**/Ex und Typ VHM*-*****/*-VRL*-*S**/Ex

Voltage	Ui	DC	24,3	V
Current	Ii		36,5	mA
Power	Pi		110	mW
Effective internal capacitance	Ci		0,12	µF
Effective internal inductance	Li			negligible

4.3 Ambient temperature range Ta -20 °C up to +50 °C

4.4 Medium temperature 0 up to +85 °C

(16) Test and assessment report
BVS PP 05.2088 EG as of 22.08.2005

(17) Special conditions for safe use
None



We confirm the correctness of the translation from the German original.
In the case of arbitration only the German wording shall be valid and binding.

44809 Bochum, 22.08.2005
BVS-Schu/Mi A 20050297

EXAM BBG Prüf- und Zertifizier GmbH

Certification body

Special services unit



1st Supplement

(Supplement in accordance with Directive 94/9/EC Annex III number 6)

to the EC-Type Examination Certificate BVS 05 ATEX E 121 X

Equipment: Flow sensor type VHM*-*****/*-V*L*-*S**/Ex
Manufacturer: VSE Volumentechnik GmbH
Address: 58809 Neuenrade, Germany

Description

The flow sensor has been tested in acc. with EN 60079.

The Essential Health and Safety Requirements of the modified equipment are assured by compliance with:

EN 60079-0:2006 General requirements
 EN 60079-11:2007 Intrinsic safety 'i'
 EN 60079-26:2004 Equipment Group II Category 1G

The marking of the equipment shall include the following:

II 1G Ex ia IIC T6

Special conditions for safe use

The volume sensor has to be mounted in such a way that sparks caused by operational friction or impact are not possible.

Test and assessment report

BVS PP 05.2088 EG as of 22.07.2009

DEKRA EXAM GmbH

Bochum, dated 22. July 2009

Signed: Simanski

Certification body

Signed: Dr. Wittler

Special services unit

Page 1 of 2 to BVS 05 ATEX E 121 X / NI

This certificate may only be reproduced in its entirety and without change.

DEKRA EXAM GmbH Dinnendahlstrasse 9 44809 Bochum Germany Phone +49 234/3696-105 Fax +49 234/3696-110 E-mail zs-exam@dekra.com
 (until 31.03.2007 EXAM BBG Prüf- und Zertifizier GmbH)



We confirm the correctness of the translation from the German original.
In the case of arbitration only the German wording shall be valid and binding.

44809 Bochum, 22. July 2009
BVS-Schu / Her A 20090572

DEKRA EXAM GmbH

A handwritten signature in black ink, appearing to be 'L. Schu', written over a horizontal line.

Certification body

A handwritten signature in black ink, appearing to be 'D. H.', written over a horizontal line.

Special services unit



Member of the FM Global Group

FM Approvals
 1151 Boston Providence Turnpike
 P.O. Box 9102 Norwood, MA 02062 USA
 T: 781 762 4300 F: 781-762-9375 www.fmapprovals.com

CERTIFICATE OF COMPLIANCE

HAZARDOUS (CLASSIFIED) LOCATION ELECTRICAL EQUIPMENT

This certificate is issued for the following equipment:

Type VHM *-***/-VaL-*S**/Ex. Flow Sensors**

IS//I/ABCD/T6..T4 @ $-20\text{ }^{\circ}\text{C} \leq T_a \leq 50\text{ }^{\circ}\text{C}$ ($-4\text{ }^{\circ}\text{F} \leq T_a \leq 122\text{ }^{\circ}\text{F}$); Entity @ $T_{med} = -20\text{ }^{\circ}\text{C}$ to $+80\text{ }^{\circ}\text{C}$ ($-4\text{ }^{\circ}\text{F}$ to $+176\text{ }^{\circ}\text{F}$)

Entity Parameters:

$U_i = 18.7\text{ V}$, $I_i = 36.5\text{ mA}$, $P_i = 110\text{ mW}$, $C_i = 0.27\text{ }\mu\text{F}$, $L_i = 0\text{ mH}$.

a = Housing:

D: Volume Sensor = 303 Stainless Steel (1.4305), preamplifier housing = aluminum;

E: Volume Sensor = 303 Stainless Steel (1.4305), preamplifier housing = aluminum;

Coil housing: Stainless Steel

* = Options not affecting safety, any single digit letter or number referring to non-electrical properties as product associates, language, delivery packing, documentation, etc.

Type VHM *-***/-VaL-*S**/Ex. Flow Sensors**

IS//I/ABCD/T6..T4 @ $T_a = -20\text{ }^{\circ}\text{C} \leq T_a \leq 50\text{ }^{\circ}\text{C}$ ($-4\text{ }^{\circ}\text{F} \leq T_a \leq 122\text{ }^{\circ}\text{F}$); Entity @ $T_{med} = -20\text{ }^{\circ}\text{C}$ to $+80\text{ }^{\circ}\text{C}$ ($-4\text{ }^{\circ}\text{F}$ to $+176\text{ }^{\circ}\text{F}$)

Entity Parameters:

$U_i = 24.3\text{ V}$, $I_i = 36.5\text{ mA}$, $P_i = 110\text{ mW}$, $C_i = 0.12\text{ }\mu\text{F}$, $L_i = 0\text{ mH}$.

a = Housing:

I: Volume Sensor = 303 Stainless Steel (1.4305), preamplifier housing = Stainless Steel;

T: Volume Sensor = 303 Stainless Steel (1.4305), preamplifier housing = Stainless Steel

R: Volume Sensor = Titanium, preamplifier housing = Aluminum; Coil housing: Stainless Steel

* = Options not affecting safety, any single digit letter or number referring to non-electrical properties as product associates, language, delivery packing, documentation, etc.



Equipment Ratings:

Intrinsically Safe with Entity Parameters for Class I, Division 1, Groups A, B, C & D hazardous (classified) locations

FM Approved for:

VSE Volumentech GmbH
Neuenrade, Germany

This certifies that the equipment described has been found to comply with the following Approval Standards and other documents:

Class 3600	1998
Class 3610	2010
Class 3810	2005

Original Project ID: 3026923

Approval Granted: September 18, 2003

Subsequent Revision Reports / Date Approval Amended

Report Number	Date	Report Number	Date
090930	January 21, 2011		
3043197	September 26, 2011		

FM Approvals LLC

J. E. Marquedant
Group Manager, Electrical

26 September 2011

Date



SAFETY DECLARATION FOR RETURN DELIVERIES (CERTIFICATE OF NON-OBJECTION)

Last revised: 10/2021

Please reply to info@vse-flow.com

Flow meters, for which this certificate of conformity has not been completed and signed, cannot be inspected or repaired for safety reasons and will be returned unchecked at your expense.

Article number	
Quantity	
Reason for return	

The flow meter was used in health/environmentally hazardous media.

 No

 Yes

The flow meter is free from residuals.

 No

 Yes

Special safety measures or treatment is necessary or expected.

 No

 Yes

The flow meter was last used with the following media:

If yes, which

	<input type="radio"/> No	<input type="radio"/> Yes*	
Solvents	<input type="radio"/> No	<input type="radio"/> Yes*	
Toxic liquids	<input type="radio"/> No	<input type="radio"/> Yes*	
Biologically active liquids	<input type="radio"/> No	<input type="radio"/> Yes*	
Radioactive liquids	<input type="radio"/> No	<input type="radio"/> Yes*	
Corrosive liquids	<input type="radio"/> No	<input type="radio"/> Yes*	
Alkali	<input type="radio"/> No	<input type="radio"/> Yes*	
Explosive liquids	<input type="radio"/> No	<input type="radio"/> Yes*	
Other media	<input type="radio"/> No	<input type="radio"/> Yes*	

* Please add the safety data sheet for the medium in the appendix.



SAFETY DECLARATION FOR RETURN DELIVERIES (CERTIFICATE OF NON-OBJECTION)

Please reply to info@vse-flow.com

The undersigned assures that the above information is correct and complete and the shipping is carried out according to legal regulations. The undersigned is liable for all damages which arise as a result of the non-marked decontamination of the returned flow meter.

VSE expressly points out that repairs and verification work is carried out by trusting the correctness of the completion of this safety declaration (certificate of non-objection). Should physical injuries, death or even damage to property occur, claims for damages will be asserted.

Company	
Street / Building no.	
Postcode / Town	
Phone	
Fax	
Email	

Contact
(in capitals)

Date

Signature
(company stamp)

Enclosed

VSE.flow®

VSE Volumentchnik GmbH
Hönnestraße 49
58809 Neuenrade / Germany

Phone +49 (0) 23 94 / 6 16-30

Fax +49 (0) 23 94 / 6 16-33

info@vse-flow.com

www.vse-flow.com

e.holding
FLUID TECHNOLOGY GROUP

www.e-holding.de