

Solutions for Fluid Technology



OPERATING INSTRUCTIONS

For Flow Meters of the Product Series "VS in Standard Version"

TABLE OF CONTENTS

	Page
Important information and legal notices	3
General function description of flow meter	4
General description	4
Flow meter selection	4
Declaration of Conformity	4
General conditions for initial start-up	4
Maximum operating pressure	5
Information on EU Directive 2014/68/EU on pressure equipment	5
Flow meter range	6
Assembly of the flow meter	6
Cleaning and flushing of pipe lines before initial start-up	7
Filtering of liquid	7
Preamplifier	7
Maintenance, service life and warranty	9
Storage, return and disposal	9
Technical specifications VS 0.02 – VS 4	10
Flow response curves VS 0.02 – VS 4	11
Dimensions VS 0.02 – VS 4	12
Dimensions, subplates AP.0.2 – 4	13
Technical specifications VS 10	14
Flow response curves VS 10	14
Dimensions VS 10	15
Dimensions, subplate APG 10	15
Type key	16
Preamplifier–block wiring diagram	18
Output signals on preamplifier	18
Plug assignment	19
Connection diagram	19
Pick-up system for high temperatures HT	19
Certificate of Non-Objection	22

The current publication of this operating instruction supersedes all information from previous publications. VSE reserves the right to make changes and substitutions. VSE is not liable for any printing errors. Reproduction, including excerpts, is permitted only after written approval by VSE. VSE reserves the right to modify technical data at any time. Last revised: 02/2022



IMPORTANT INFORMATION AND LEGAL NOTICES

Dear customer, dear user,

This operating instruction for volume sensors of the **“VS in Standard Version”** series by VSE Volutentechnik GmbH (VSE) contains information required to properly install and commission the flow meter for the intended purpose.

Any installation, commissioning, operation, maintenance and testing may only be carried out by trained and authorized personnel. The operating instructions must be read and followed carefully to ensure a trouble-free, proper and safe operation of the flow meter. In particular, the safety instructions are essential.

These operating instructions must be kept safe and accessible for the authorized personnel at all times. At no time should contents of the operating instructions be removed. A missing manual or missing pages must be replaced immediately if lost. The operating instructions can be requested at any time from VSE or downloaded from our website www.vse-flow.com. The operating instructions must be passed on to each subsequent user of the flow meter.

This operating instruction is not subject to any modification service by VSE. VSE reserves the right to make technical changes at any time without notice.

VSE makes no warranties, express or implied, with respect to commercial qualities and suitability for a particular purpose.

VSE accepts no liability for damage and malfunctions resulting from operating errors, failure to observe these operating instructions, improper installation, commissioning or maintenance as well as improper use of the flow meter.

The opening of the flow meter is absolutely not permitted. After an unauthorized opening or rebuilding as well as after a single, incorrect connection of the flow circuits of the flow meter, the warranty as well as the product liability by VSE expire.

GENERAL FUNCTION DESCRIPTION OF FLOW METER

Flow meters made by VSE Volumentechnik GmbH measure the volume flow of liquids according to the toothed wheel principle. A pair of very precisely adjusted toothed wheels in the housing constitutes the meter. A signal pick-up system registers meter rotation free of contact and tooth by tooth. Each tooth is put out as digital pulse.

The gaps in the teeth of the meter wheels form meter chambers in the areas, in which they are completely enclosed by the housing walls; these chambers digitalise liquid flow depending on their chamber volume. The liquid flow quantity within one meter rotation of a tooth division forms the volume measurement per pulse (V_m) and is defined in cm^3/pulse . It identifies the constructional size of a flow meter.

GENERAL DESCRIPTION

Please follow all instructions in this operating manual; only this guarantees a trouble-free operation of the flow meters. VSE is not liable for any damage ensuing from non-following of these instructions.

Opening the devices during the term of guarantee is only authorised after consultation and approval of VSE.

FLOW METER SELECTION

The correct selection (version) of type and constructional size is crucial for a trouble-free and safe operation of the flow meters. Owing to the great number of various applications and flow meter versions, the technical specifications in the VSE catalogue material are of a general

nature. Performance of the flow meter depends on type, size and meter range and on the liquid that is to be measured. Please consult VSE for an exact description.

DECLARATION OF CONFORMITY

Flow meters of the "VS" product line are tested for their electromagnetic compatibility and interference transmission in terms of the law on electro-magnetic compatibility and correspond to the legal prescriptions enforced by EMC directives. They may not be operated independently and are to be connected via cable to a power source and supply digital electric signals for electronic evaluation. A declaration of conformity is submitted for all flow meters, which you can request if you require. Since the electromagnetic compatibility of the total measuring system depends as well on cable layout, correct connection of protective shield-

ing and each single connected device, you must ensure that all components correspond to the electromagnetic compatibility directives and that the electromagnetic compatibility of the total system, machine or plant is guaranteed.

All flow meters are tested according to the valid, legally prescribed electromagnetic compatibility directives and possess the CE-certification. The EC-declaration of conformity is the CE-label attached to all flow meters.

GENERAL CONDITIONS FOR INITIAL START-UP

Before assembly and before initial start-up, you have to note the following properties and aspects of the corresponding characteristics of your system, so that a trouble-free and safe operation is possible.

1. The process fluid

- Is the flow meter **suitable for the fluid**?
- Is the fluid **viscous or abrasive**?
- Is the fluid **contaminated** or is there **solid matter in the fluid**?
- Which **granular size** does the solid matter possess and can it **block the meter**?
- Does the fluid have **fillers** or other **additional material**?
- Is it necessary to install a pre-switched **hydraulic filter**?
- Are the **pipe lines clean** and free of assembly residues such as swarf, weld chips?
- Is the **tank clean** and is it ensured that **no extraneous materials** can get into the pipe line system from the tank?
- Is the fluid often changed and is **sufficient flushing performed in this case**?
- Are the pipe lines and the entire system completely **deaerated**?
- What **cleaning agent** is being used?
- Are the fluid and the cleaning agent compatible with the **seals**?
- Are the **seals suitable** for the fluid undergoing measurement (**seal compatibility**)?

2. The hydraulic properties of the system

- Is the **max. operating pressure of the system** lower than the max. permitted operating pressure of the flow meter?
- Is the **max. fall of pressure Δp** (on flow meter) below the max. permitted fall of pressure?
- Does an excessively **great fall in pressure Δp** occur on the flow meter at max. flow (e.g. with higher viscosity)?
- Does the flow range of the flow meter (depending on viscosity) correspond to the **provided flow**?
- Note that flow range decreases the **greater the viscosity!**
- Does the temperature range of the flow meter correspond to the **provided max. temperature** of the medium?
- Is the **cross section** of the pipe line large enough and are the falls in pressure in the system not excessive?
- Is the **hydraulic connection** (supply and reverse flow) correctly connected and leak-proof?
- Has the **pump** sufficient power to operate the system?
- A blocking flow meter can stop the whole flow. Is a **pressure control valve / bypass** provided in the system?

3. Electronic evaluation and electrical safety

- Have you selected the optimal flow meter and is this equipped with the **appropriate preamplifier**?
- Does the **power supply voltage** of the flow meter correspond to the provided voltage?
- Is the power supply voltage supplied by the mains or evaluation device sufficiently **steady**?
- Does the **output** of the power supply voltage correspond to the required power output?
- Has the electric connection been installed based on the enclosed **connection plan**?
- Is the cable **protected** by a shielding?
- Is there a **connection** of the cable protective shielding via the 4-pin round plug to the housing of the flow meter?
- Is there a **potential difference** between the earth conductor connection PE on the flow meter and the earth conductor PE on the evaluation device?
- Does a correcting lead have to be laid to eliminate the **potential difference** between the flow meter and the evaluation device?
- Is the flow meter connected firmly to the **earth conductor PE** (e.g. via the pipe lines)?
- Is the flow meter mounted to be **insulated** to the earth conductor PE (e.g. connection via hoses)? If this is the case, the earth conductor PE has to be connected to the flow meter!
- Is the cable laid fault-free and the installation secured from input of **interference pulses**?
- Is the **round plug** of the connection cable firmly screwed together with the plug of the flow meter?
- Are the wires on the **evaluation device** correctly and properly connected?
- Does the entire system correspond to the directives of the electromagnetic compatibility laws (**EMC**)?
- Have all local valid regulations, **applicable directives**, guidelines and background conditions of the **electromagnetic compatibility laws** been maintained and observed?
- Systems that can lead to personal injury through malfunction or failure are to be equipped with the **appropriate safety devices**. The functioning of these safety devices is to be checked at regular intervals.

MAXIMUM OPERATING PRESSURE

Before assembling the flow meter, you have to test that the max. operating pressure of the system does not exceed the max. permitted operating pressure of the flow meter. Meanwhile, observe the top pressures that can occur, when operating the system.

The following operating pressures are permitted depending on flow meter version:

- Flow meter in grey cast iron version $p_{max} = 315 \text{ bar} / 4500 \text{ psi}$
- Flow meter in stainless steel version $p_{max} = 450 \text{ bar} / 6500 \text{ psi}$
- Flow meter in special version $p_{max} = \text{up to } 700 \text{ bar} / 10100 \text{ psi}$

Important:

Please consult VSE for all operating pressures > 450 bar / 6500 psi and for special versions.



INFORMATION ON EU DIRECTIVE 2014/68/EU ON PRESSURE EQUIPMENT

In terms of Article 2, No. 5 of the directive named above, VSE volume sensors are so-called "pressure-maintaining components" and this directive thereby relates to them.

VSE volume sensors must thereby comply with the technical requirements named in Section 4 of the directive in accordance with Article 4, Paragraph (1d), Piping according to Paragraph (1c).

Typically, the fluids measured fall into Group 2 in accordance with Article 13, Paragraph (1b). The volume sensors sold by VSE do not comply with the limit values defined under Article 4, Paragraph (1a).

The technical requirements on volume sensors from VSE are therefore limited to the criteria defined in Article 4, Paragraph (3). That means that the devices must be designed and manufactured in accordance with the good engineering practices prevailing in the member state. We hereby confirm this. The paragraph also states that these units may not bear the CE label named in Article 18.

A CE declaration of conformity is therefore not issued in accordance with 2014/68/EU.

The CE label of our volume sensors refers to Directive 2014/30/EU.

FLOW METER RANGE

The flow meter range specified in the flow meter data sheet (Q_{\min} - Q_{\max}) refers to the testing fluid "hydraulic oil" with a viscosity of 21 mm²/s at a temperature of 20°C. For this flow meter range, VSE specifies measurement accuracy of up to 0.3% of the measurement value and a repetition accuracy of 0.05%.

For fluids of lower viscosity (< 21 mm²/s) measurement accuracy deteriorates, while for fluids of higher viscosity (> 21 mm²/s) it can improve. Also note, however, that the flow meter range is restricted in case of higher viscosity (see "Technical specifications").

Important:

Make sure that the specified maximum permitted operating pressure of the flow meter cannot be exceeded, whatever the operating mode of the system. Note the flow meter range that is dependent on the viscosity of the fluid to be measured.



ASSEMBLY OF THE FLOW METER

The flow meter should be mounted on an easily accessible location, so that dismantling for cleaning the meter presents no problem. Since flow meters can work in any installation position and flow direction, you can mount it on any location of your system that you wish. Take care when installing the flow meter that always liquid remains in the flow meter even at system standstill and that it can never run empty. The outflow of the flow meter should therefore always show a certain back pressure. In critical cases or when the pipe line is at standstill or standby and can run empty, we recommend installing an extra non-return valve in the outflow line.

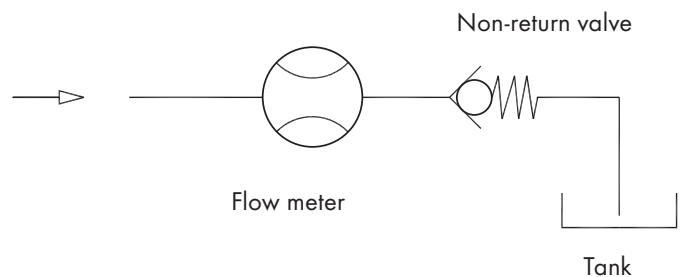

Fig. 1: Flow meter installation with non-return valve

Important:

Make sure that the flow meter is always completely filled both in inflow and outflow and that the outflow has a little back pressure. This prevents the meter being damaged by a sudden and steep increase of flow and at the same time improves measurement accuracy.



Flow meters of the "VS" product line can be mounted directly onto a block or into the pipe line using four screws. Always select large cross sections for the hydraulic supply and return flow respectively for the entire pipe line system (if possible). This lowers the fall in pressure and the flow rate in the total system.

VSE supplies subplates for all flow meters of the "VS" product line; they have various pipe threads and side or rearside connection. Depending on the provided conditions, the installed pipe line, the pipe cross section or pipe thread, the operator can choose the suitable subplate and incorporate this into the system or machine without additional reductions.

The flow meter is screwed onto the block or subplate with four DIN 912 cheese head screws. The screws are to be evenly pre-tensed crosswise with the following torques.

When changing the fastening screws you must take great care that the screws are of property class 10.9 and 12.9.

Table 1: Torque of fastening screws

Flow meter, size (cast iron and 1.4305)	Torque
VS 0.02; VS 0.04; VS 0.1; VS 0.2	15 Nm
VS 0.4; VS 1; VS 2	35 Nm
VS 4	120 Nm
VS 10	250 Nm

Please note the special instructions for mounting sizes VS 4 and VS 10 (see appendix)

Important:

When mounting the flow meter, you must take great care that the seals are not damaged and correctly placed in the hydraulic connections of the flow meter. Wrongly installed or damaged seals lead to leakage and to an leaky system, which may have dire consequences.

Please make sure that flow meters with EPDM seals do not come into contact with oil and greases on a mineral oil basis. These fluids can decompose the seals.

The yellow plastic plugs in the hydraulic connections of the flow meter protect the meter against dirt and contamination during storage and shipping. Before mounting the flow meter you have to remove these plugs so that in- and outflow is free and open.



CLEANING AND FLUSHING OF PIPE LINES BEFORE INITIAL START-UP

Before initial start-up of the flow meter, you must flush and clean the whole system. Contaminated fluids can affect the correct function of the flow meter or seriously damage the meter.

After preparing and connecting up the system pipes, you must first carefully flush and clean the whole pipe line system and the tank. To do this, you have to mount a diversion plate onto the block or subplate instead of the flow meter, so that the fluid can flow through the diversion plate and all extraneous material (e.g. swarf, metal chips, etc.) can be flushed out without obstruction. Use a fluid as cleansing agent, which is compatible with the fluid being used later and which does not cause undesirable reactions. You can consult the suppliers and manufacturers of the fluid or contact VSE for the corresponding information. VSE supplies bypass-plates the corresponding for all VS flow meter sizes.

Flow meters are measurement pick-up systems made with high-level precision. They have a mechanical meter consisting of two toothed wheels and which is adapted to the housing with narrow slots. Even the tiniest damage to the toothed wheels and bearings can cause a measurement error. So always make sure that no extraneous material gets into the meter and that the fluid flowing through is always free from dirt and contamination.

After the system has been carefully flushed out and no extraneous material is in the pipe line, you can mount the flow meter and commence the initial start-up.

Important:

Please flush out the pipe lines and the tank thoroughly, to prevent contamination with the flow meter.



FILTERING OF LIQUID

Strongly contaminated fluid or extraneous material in the fluid can block, damage or even destroy the flow meter. Always install a sufficiently large filter for these cases in front of the flow meter to prevent damage. The necessary filtering depends on size, bearing system and version of flow meter.

Table 2: Pre-switched filters

Flow meter size	Filter size for ball bearings
VS 0.02 / 0.04 / 0.1	10 µm
VS 0.2 / 0.4	20 µm
VS 1 / 2 / 4 / 10	50 µm

For information on filter size for flow meters with plain bearings, in special version, or with specially adjusted meter tolerances, please consult VSE Volumentchnik GmbH.

Important:

A blocking flow meter can stop the whole flow. You have to provide a control valve / bypass for the system.



PREAMPLIFIER

The preamplifier for the standard version is short-circuit-proof, reverse-polarity-proof and processes the signals of the scan sensors. A high level of interference protection is achieved through the push-pull output stages of the preamplifier. You can easily connect evaluation devices

with both PNP and NPN inputs to the outputs. The two-channel output of digital signals enables a higher measurement resolution and also a direction recognition of the flow.

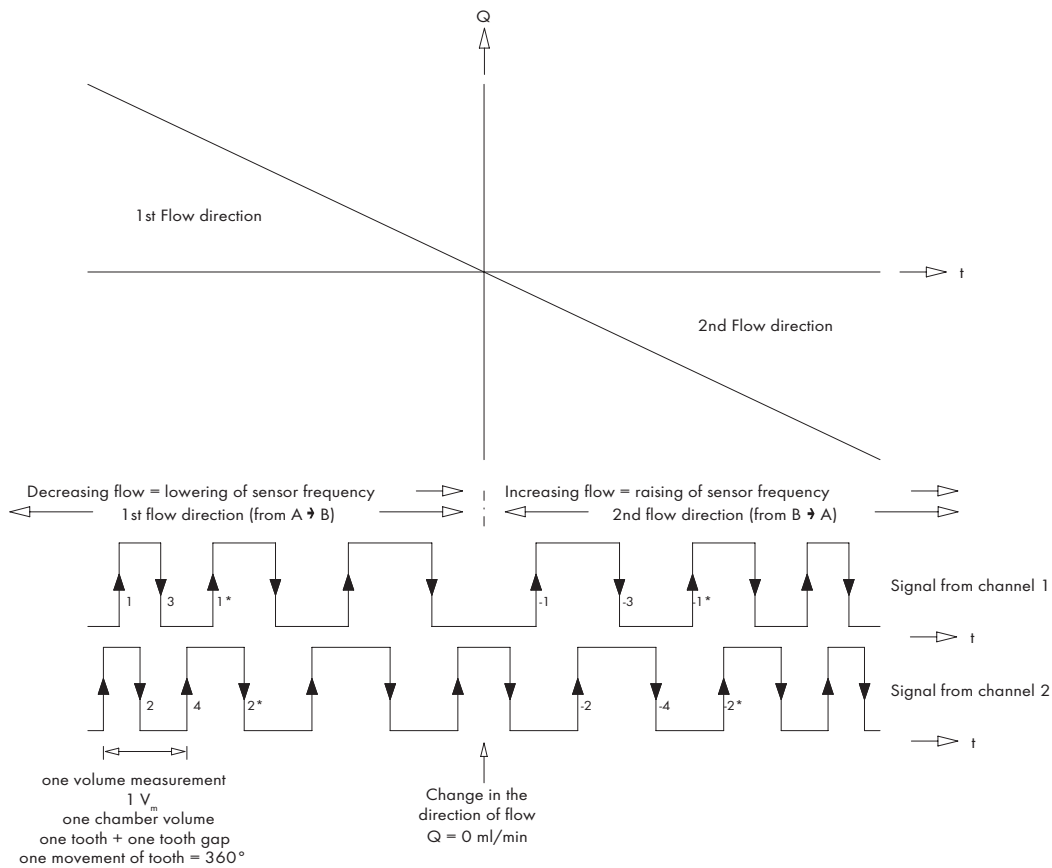

Fig. 2: Signal output of preamplifier

The power supply voltage range is $U_b = 10 \dots 28$ V DC. You can operate the preamplifier with any voltage in this voltage range U_b but make sure that the signal voltage is always adjusted to the power supply

voltage. Permitted for the power supply is a steady direct voltage with a maximum residual ripple of $\pm 15\%$.

Important:

Please make sure that no extra inductive elements are connected in the power supply of the flow meter, such as contactors, relays, valves etc. These components are potential sources of interference, which generate high interference pulses when switched and can interfere with the functioning of the flow meter, although this complies with the electromagnetic compatibility directives (especially if the inductive elements are not provided with an adequate protective circuit).



The no-load current reception of the preamplifier depends on each power supply voltage.

Power supply voltage $U_b = 12$ V DC $I_{0max12} = 25$ mA
 Power supply voltage $U_b = 24$ V DC $I_{0max24} = 40$ mA
 Max. current per channel $I_{Kmax} = 20$ mA

(the current I_K is dependent on the input impedance of the evaluation electronics)

Total current reception (at 12 V DC) $I_{0tot.} = 65$ mA
 $I_{0tot.} = I_{0max12} + (2 \times I_{Kmax})$ $P_{max} = 0.78$ W

Total current reception (at 24 V DC) $I_{0tot.} = 80$ mA
 $I_{0tot.} = I_{0max24} + (2 \times I_{Kmax})$ $P_{max} = 1.92$ W

The electric connection of the flow meter is performed via the 4-pin round plug located on the preamplifier housing. The connection cable plug is plugged into the plug connection of the flow meter and screwed together.

Important:

Only use well-shielded cables for the connection cable, with a wire cross section of $\geq 4 \times 0.25$ mm². Please make sure that the housing of the round plug is metallic, that it has a connection for the shielding and that the potential of the earth conductor PE is connected to the housing.



The shielding of the connection cable could be placed on both sides. The earth conductor PE is then connected via the shielding from the evaluation electronics to the preamplifier housing and the meter. The cable shielding should always be laid continuously as far as the flow meter and not interrupted in cross connectors or branch sockets. Lay the connection cable as directly as possible from the evaluating device to the flow meter, since interruptions are always a potential source of error.

The flow meter must be connected electrically with the earth conductor PE. This is normally secured by the earthed pipe lines.

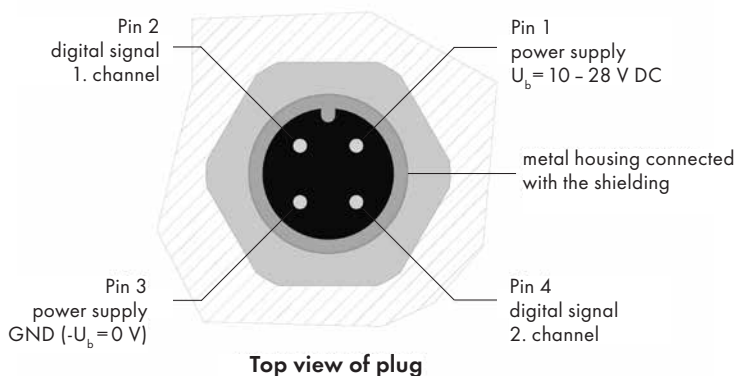

Fig. 3: M12 plug connector installed in the preamplifier housing of the flow meter

Important:

If there are potential differences between the preamplifier housing and the earth conductor PE of the evaluating electronics, you have to lay a potential equalisation (see connection diagram).



The maximum cable length between flow meter and the evaluation electronics is approx. 120 m. With extensive cable lengths (as of approx. 40 m) you must take care that the connecting cable is laid in an in-

terference-free environment, that the shielding is preferably connected on both sides of the earth conductor PE and that there is no potential difference between the two earth conductor connections.

MAINTENANCE, SERVICE LIFE AND WARRANTY

Depending on the operating conditions, the service life and therefore the specific properties of the units are limited by wear, corrosion, deposits or ageing. The operator is responsible for regular inspection, maintenance and recalibration. Any observation of a malfunction or damage prohibits further use. On request, we can provide you with a

loan unit for the duration of the overhaul. We recommend an annual check and recalibration. Under normal operating conditions, the service life is 10,000 hours.

The warranty period is 12 months.

STORAGE, RETURN AND DISPOSAL

Temporary storage

All VSE flow meters are supplied with sealing plugs and in suitable packaging for all destinations and modes of transport to ensure optimum protection. The flow meters should always be stored in their original foam packaging or transport box.

The units must not be exposed to temperatures below -20°C or above $+60^{\circ}\text{C}$ and must be protected from moisture and its effects.

Return

1. The flow meter must be properly cleaned by the customer before being returned to prevent the risk of poisoning/contamination by harmful, explosive and other high-risk pumped media for humans and the environment.
2. If media have been conveyed whose residues with atmospheric humidity lead to corrosion damage or ignite on contact with oxygen, the flow meter must be additionally neutralised and thoroughly cleaned with anhydrous, inert gas to dry.
3. The return of the flow meter must always be accompanied by a fully completed declaration of no objection (see page 22). All applied safety and decontamination measures must be indicated.
4. When returning the flow meter, it must be packed in accordance with the applicable logistics standards and sealed with sealing plugs.

Disposal

VSE actively promotes environmental awareness and has an operational management system that meets the requirements of ISO 9001:2015. The impact on the environment and people should be minimised during the production, storage, transport, use and disposal of our products and solutions.

- Collect rinsing liquid as well as residual liquid and dispose of it in accordance with the statutory provisions and regulations.
- Wear protective clothing and protective mask/+ goggles if necessary.

Materials must be disposed of properly as follows:

- Metal
- Plastics
- Electronic components
- etc.

When disposing of the materials, ensure that the waste-relevant rules and regulations of the respective country of destination are observed!

TECHNICAL SPECIFICATIONS VS 0.02 – VS 4

Size	Measuring range l/min	Frequency Hz	Pulse value cm ³ /pulse	K-factor pulse/litre
VS 0.02	0.002 ... 2	1.667 ... 1666.67	0.02	50 000
VS 0.04	0.004 ... 4	1.667 ... 1666.67	0.04	25 000
VS 0.1	0.01 ... 10	1.667 ... 1666.67	0.1	10 000
VS 0.2	0.02 ... 18	1.667 ... 1500.00	0.2	5 000
VS 0.4	0.03 ... 40	1.250 ... 1666.67	0.4	2 500
VS 1	0.05 ... 80	0.833 ... 1333.33	1	1 000
VS 2	0.1 ... 120	0.833 ... 1000.00	2	500
VS 4	1.0 ... 250	4,167 ... 1041.67	4	250

Measurement accuracy	up to 0.3% of measurement value (with viscosity > 20 mm ² /s)
Repetition accuracy	± 0.05% under the same operating conditions
Material	Cast iron EN-GJS-400-15 (EN 1563) or Stainless steel 1.4305
Meter bearing	Ball bearings or steel plain bearings (medium-dependent)
Seals	FPM (standard), NBR, PTFE or EPDM
Max. operating pressure	Cast iron EN-GJS-400-15 (EN 1563) 315 bar/4500 psi Stainless steel 1.4305 450 bar/6500 psi
Medium temperature	-40 ... + 120°C (-40°F ... 248°F)
Ambient temperature	-20 ... + 50°C (-4°F ... 122°F)
Viscosity range	1 ... 100 000 mm ² /s
Installation position	any
Flow direction	any
Running noise	max. 72 db(A)
Power supply version	10 to 28 volts/DC
Pulse output	2 x push-pull output stages reverse-polarity-proof, short-circuit-proof low signal: 0 = GND; high signal: 1 = U _b -1 I _{max} = 80 mA (at 24 V) P _{max} = 1.92 W (at 24 V)
Channel offset	90° ± 30° max.
Pulse-width repetition rate	1/1 ± 15° max.
Preamplifier housing	Aluminium
Protection type	IP 65

VS 0.02

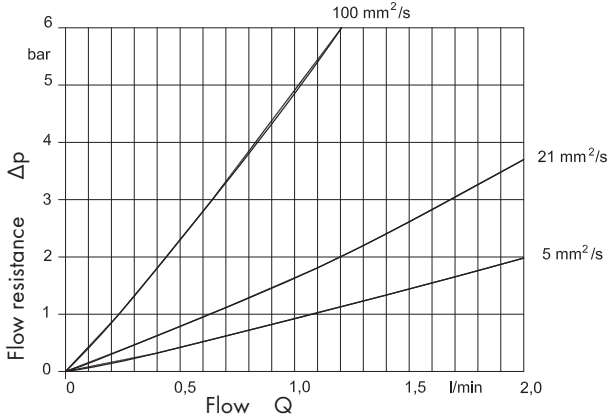

VS 0.04

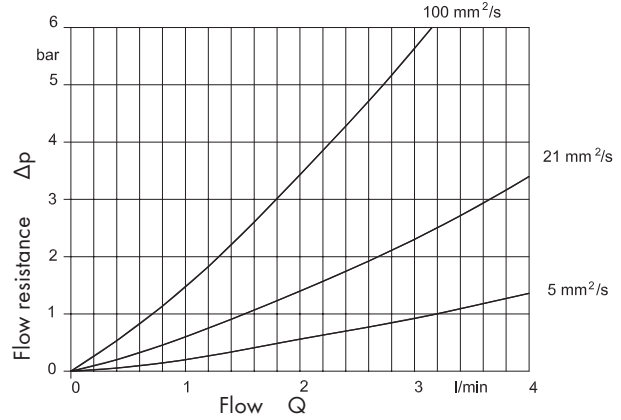

VS 0.1

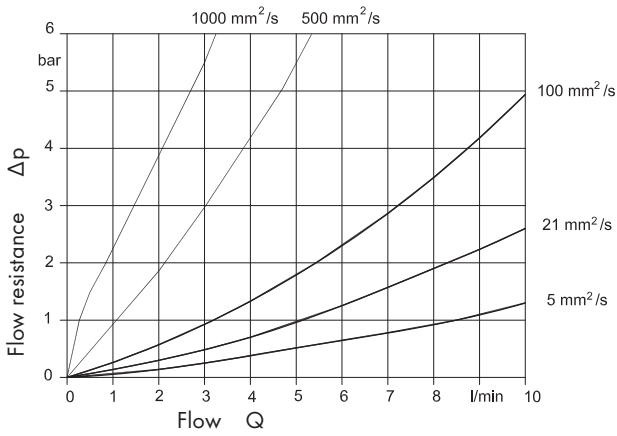

VS 0.2

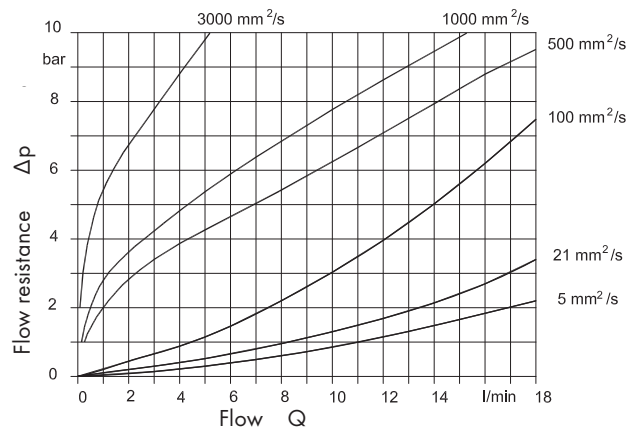

VS 0.4

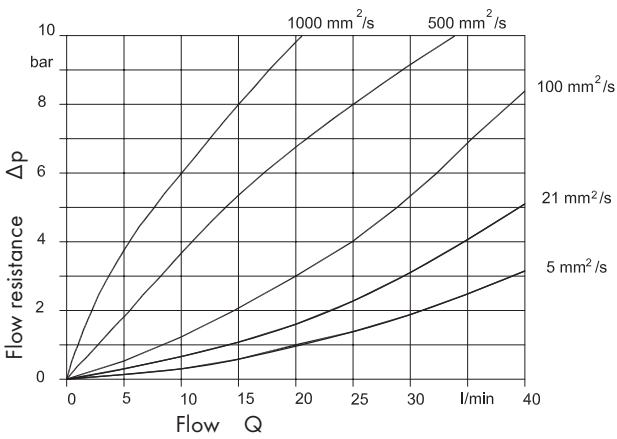

VS 1

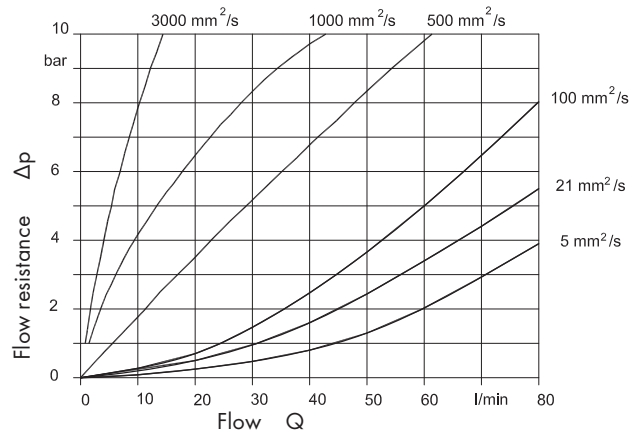

VS 2

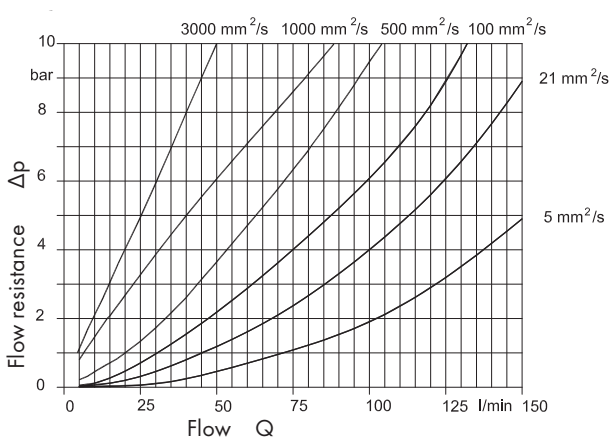

VS 4

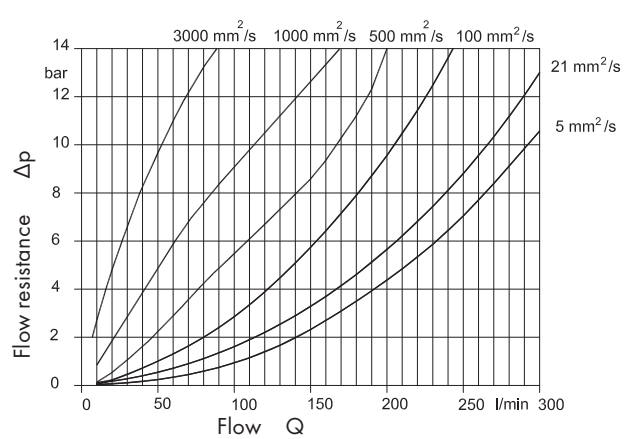

DIMENSIONS VS 0.02 – VS 4

Cast iron version

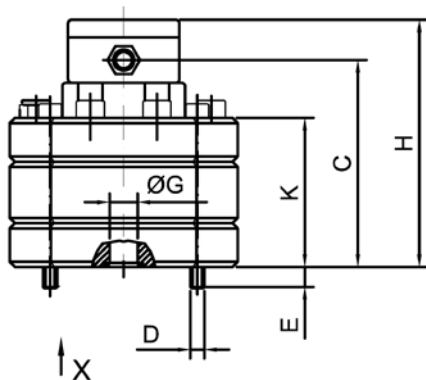

Stainless steel version
Connection diagram
Housing without milled edge

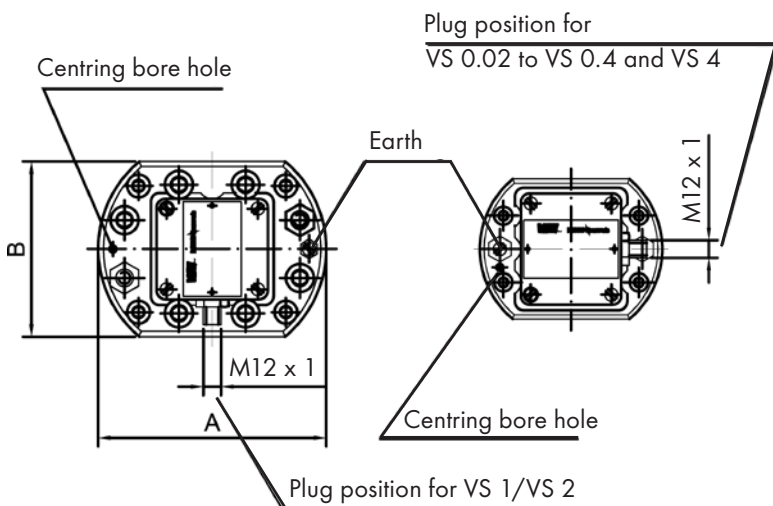
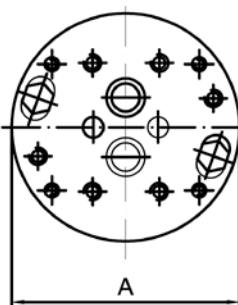

Cast iron version
Connection diagram

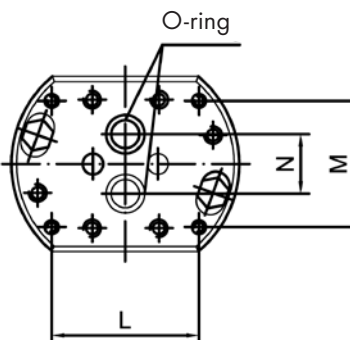

size	A	B	C	D	E	øG	H	K	L	M	N	O-ring	Weight GCI kg	SS kg
VS														
0.02	100	80	91	M6	12.0	9	114	58	70	40	20	11 x 2	2.8	3.4
0.04	100	80	92	M6	11.5	9	115	59	70	40	20	11 x 2	2.8	3.4
0.1	100	80	94	M6	9	9	117	61	70	40	20	11 x 2	2.8	3.4
0.2	100	80	94	M6	9.5	9	117	61	70	40	20	11 x 2	3.0	3.7
0.4	115	90	96.5	M8	11.5	16	120	63.5	80	38	34	17.96 x 2.62	4.0	5.0
1	130	100	101	M8	12.5	16	124	68	84	72	34	17.96 x 2.62	5.3	6.8
2	130	100	118	M8	15	16	141	85	84	72	34	17.96 x 2.62	6.7	8.4
4	180	140	143	M12	20	30	166	110	46	95	45	36.17 x 2.62	14.7	18.4

Dimensions in mm

Connection position, side

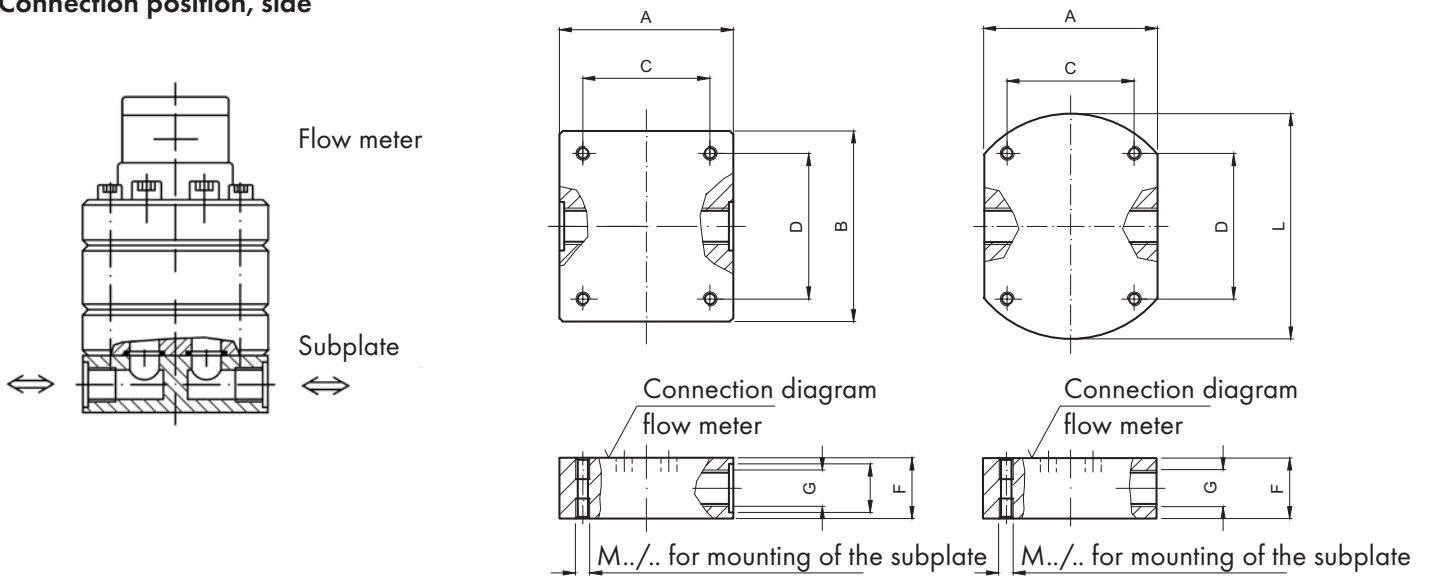

Size	Connection thread	F	øH	A	B	C	D	E	L	Thread/depth	Weight
VS	G									M	kg
0.02	G 1/4"	35	20	80	90	40	70	26	100	M6/12	1.8
0.04	G 3/8"		23					30			
0.1	G 1/2"		28					38			
0.2											
0.4	G 1/2"	35	28	90	100	38	80	46	115	M8/15	2.7
	G 3/4"	40	33					52			
1	G 1/2"	35	28	100	110	72	84	46	130	M8/15	3.6
2	G 3/4"	40	33					52			
	G 1"	55	41					55			
4	G 1 1/4"	70	51	120	130	100	110	60	M8/15	7.4	
	*G 1 1/2"	70	56	140			120	72			
	G 1 1/2"	80		110			180	12.0			

only for AP. 4 U...

Connection position below

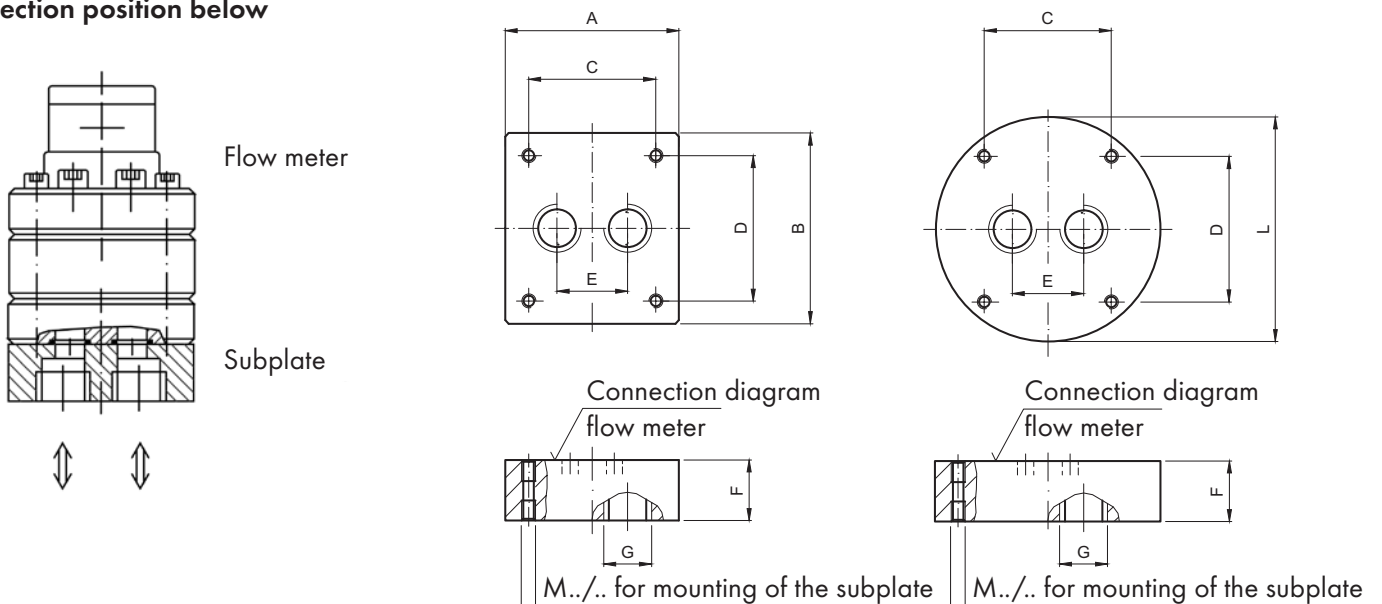

TECHNICAL SPECIFICATIONS VS 10

Size	Measuring range l/min	Frequency Hz	Pulse value cm ³ /pulse	K-factor pulse/litre
VS 10	1.5 ... 525	7.50 ... 2625.00	3.333	300
Measurement accuracy	up to 0.3% of measurement value (with viscosity > 20 mm ² /s)			
Repetition accuracy	± 0.05% under the same operating conditions			
Material	Cast iron EN-GJS-600-3 (EN 1563)			
Meter bearing	Ball bearings or steel plain bearings (medium-dependent)			
Weight	70 kg without subplate			
Seals	FPM (standard), NBR, PTFE or EPDM			
Max. operating pressure	420 bar/6000 psi			
Medium temperature	-40 ... 120°C (-40°F ... 248°F)			
Ambient temperature	-20 ... + 50°C (-4°F ... 122°F)			
Viscosity range	5 ... 100 000 mm ² /s			
Installation position	any			
Flow direction	any			
Running noise	> 80 db(A)			
Power supply version	10 to 28 volts/DC			
Frequency range	0 ... 2625 Hz			
Pulse output	2 x push-pull output stages reverse-polarity-proof, short-circuit-proof low signal: 0 = GND; high signal: 1 = U _b -1 I _{max} = 80 mA (at 24 V) P _{max} = 1.92 W (at 24 V)			
Channel offset	90° ± 30° max.			
Pulse-width repetition rate	1/1 ± 15° max.			
Preamplifier housing	Aluminium			
Protection type	IP 65			

FLOW RESPONSE CURVES VS 10

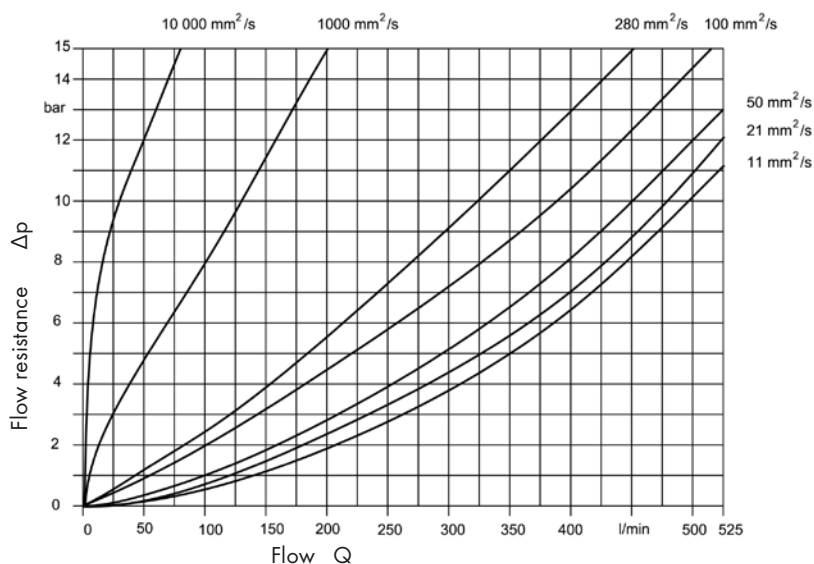

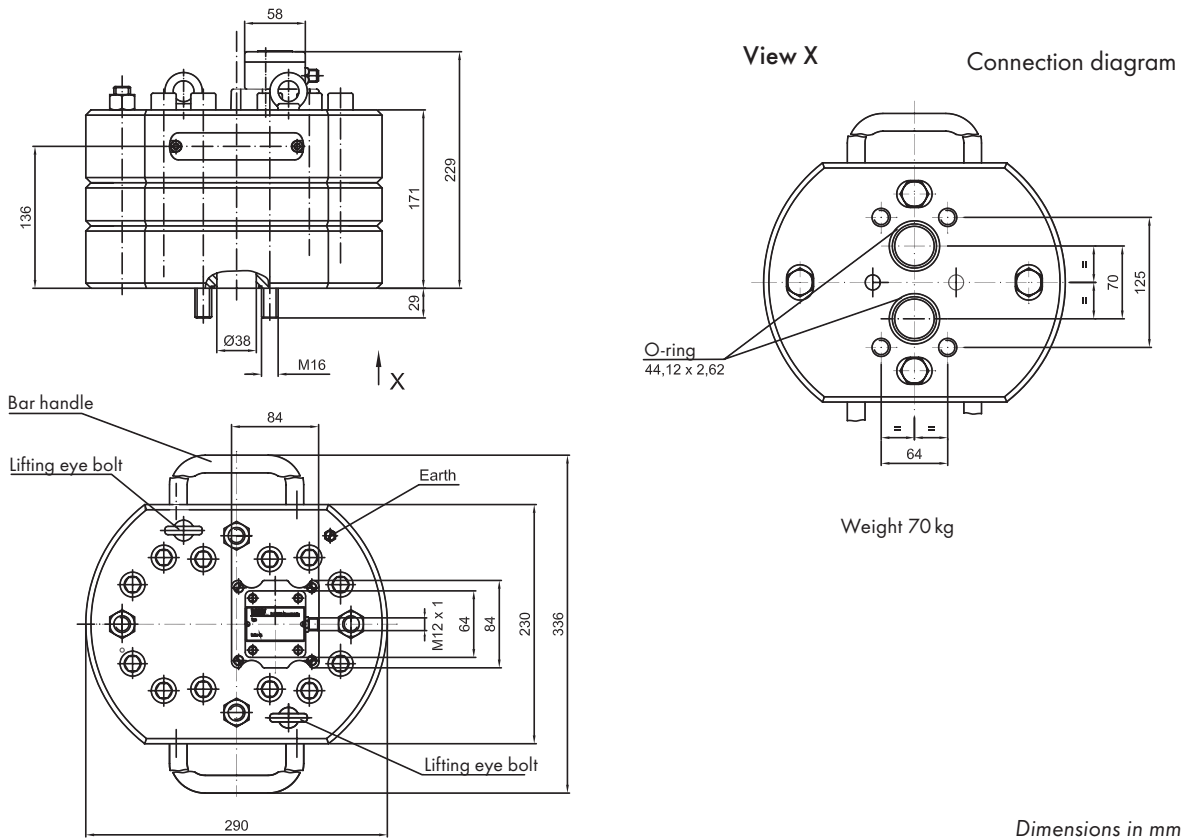

DIMENSIONS, SUBPLATE APG 10.

APG 10 SG0N / 1

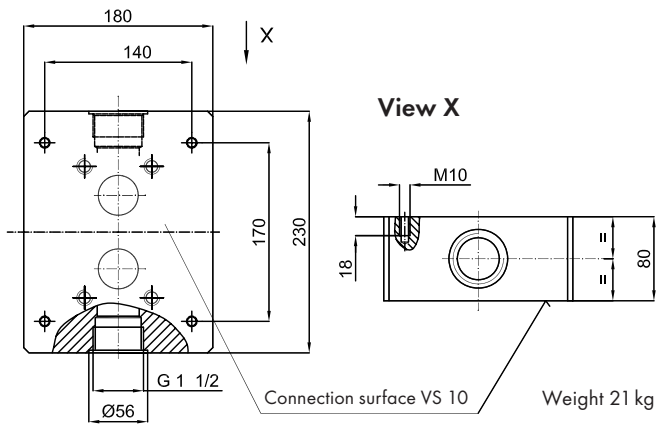

APG 10 SW0N / 1

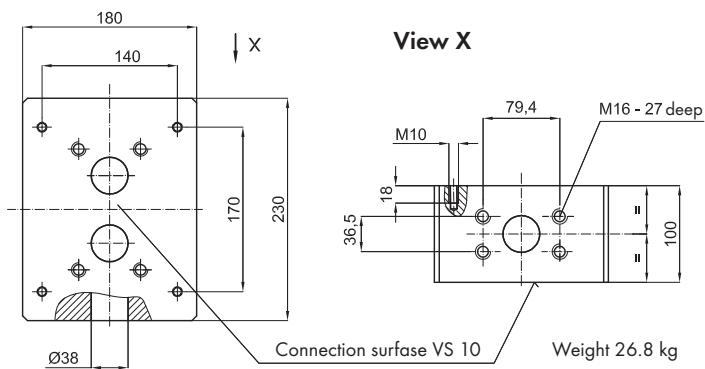

Subplates AP...

Example:

A	P	G	1	-	S	C	0	N	/	X			
		Material	Size								Product line		
							Connection thread	Accessory connection	Version		Modification Id. No.		
								N	Standard version				
								S	Special version				
							0	Without rinse connection					
							A	G 1/4					
							B	G 3/8					
							C	G 1/2					
							D	G 3/4					
							E	G 1					
							F	G 1 1/4					
							G	G 1 1/2					
							J	1/4 NPT					
							K	3/8 NPT					
							L	1/2 NPT					
							M	3/4 NPT					
							N	1 NPT					
							O	1 1/4 NPT					
							P	1 1/2 NPT					
							S	SAE 1/2					
							T	SAE 3/4					
							U	SAE 1					
							V	SAE 1 1/4					
							W	SAE 1 1/2					
							X	SAE 2					
							S	Side connection					
							U	Bottom connection					
			0,2	VS 0,02 to VS 0,2 / VSI 0,02 to VSI 0,2									
			0,4	VS 0,4 / VSI 0,4									
			1	VS 1 / VS 2 / VSI 1 / VSI 2									
			4	VS 4 / VSI 4									
			10	VS 10 / VSI 10									
Subplate	G	EN-GJL-250, EN-GJS-400-15 DIN EN 1561/ 1563											
	E	Stainless steel 1.4305											
	H	EN-GJS-600-3 DIN EN 1563 (high pressure)											

PREAMPLIFIER-BLOCK WIRING DIAGRAM

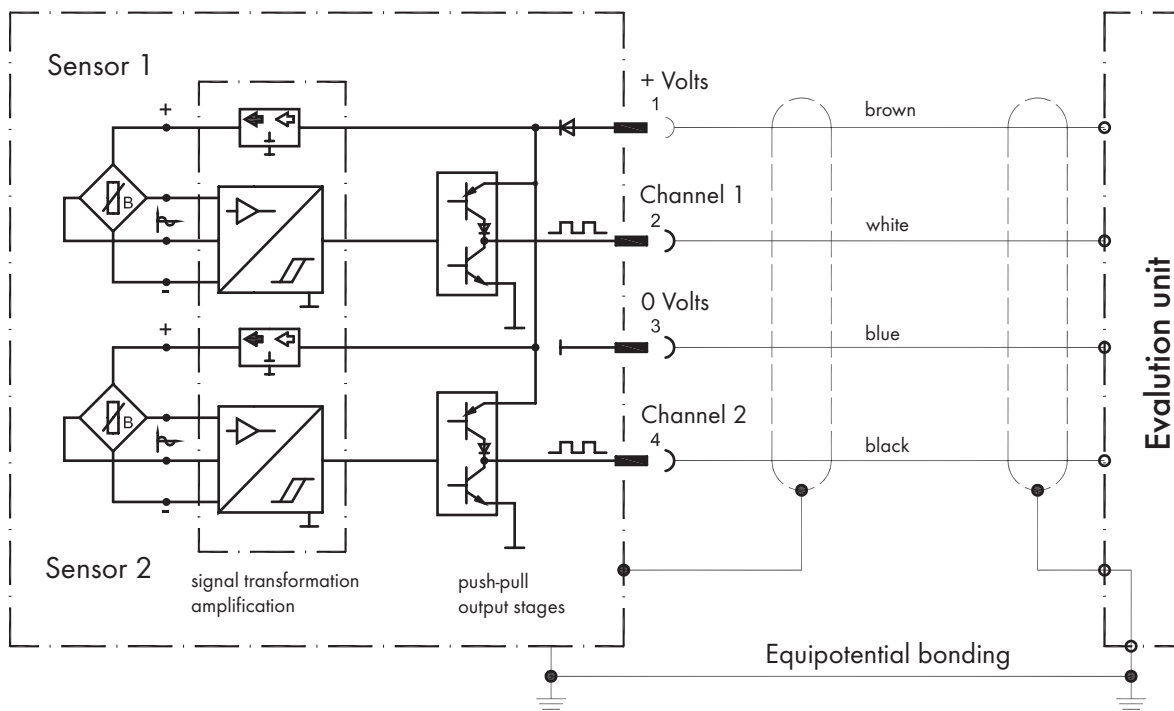

OUTPUT SIGNALS ON PREAMPLIFIER

Flow meter VS 0.02 ... VS 4

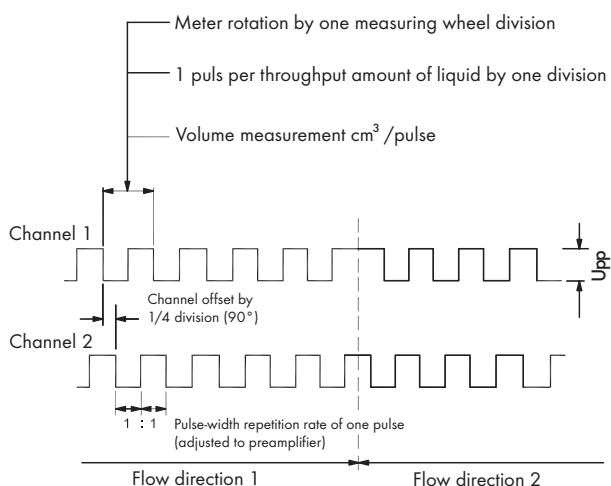

Flow meter VS 10

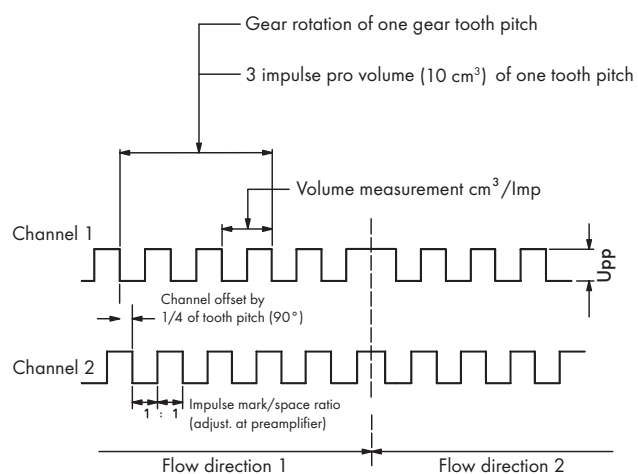

Voltage ranges

Power supply voltage: $U_v = 10 \dots 28 \text{ V DC}$

Signal voltage: $U_{ss} = U_v - 1 \text{ V}$

PLUG ASSIGNMENT

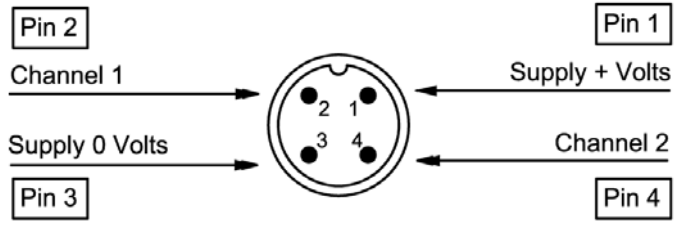
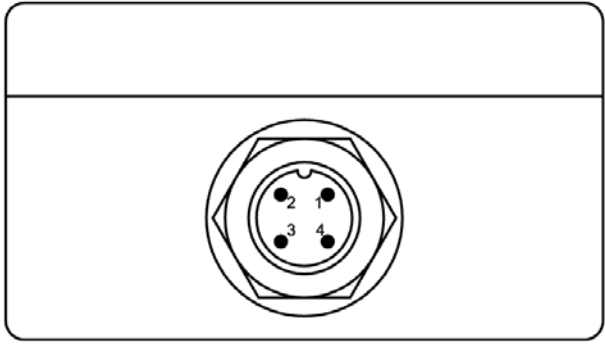

CONNECTION DIAGRAM

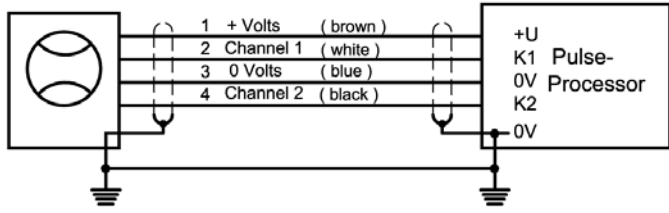

Modification of flow direction indication (+ to - / - to +) by interchanging channels (channel 1, channel 2)

PICK-UP SYSTEM FOR HIGH TEMPERATURES HT

For medium temperatures >120°C, the high temperature (HT) versions by VSE have to be deployed. Flow meters of stainless steel are used exclusively in this case.

The sensor or pick-up system consists of a sensor unit, which is screwed into the cover of the flow meter and a downstream amplifier. The amplifier is connected with the flow meter via a temperature-stable cable

and has to be installed outside the high temperature zone. The ambient temperature should be no more than 50°C in this area.

The digital signals are emitted as PNP- or NPN-signals, depending on amplifier version.

With extensive cable lengths, we recommend using shielded cables and a pull-down (PNP signal) or pull-up impedance (NPN signal).

Plug assignment HT

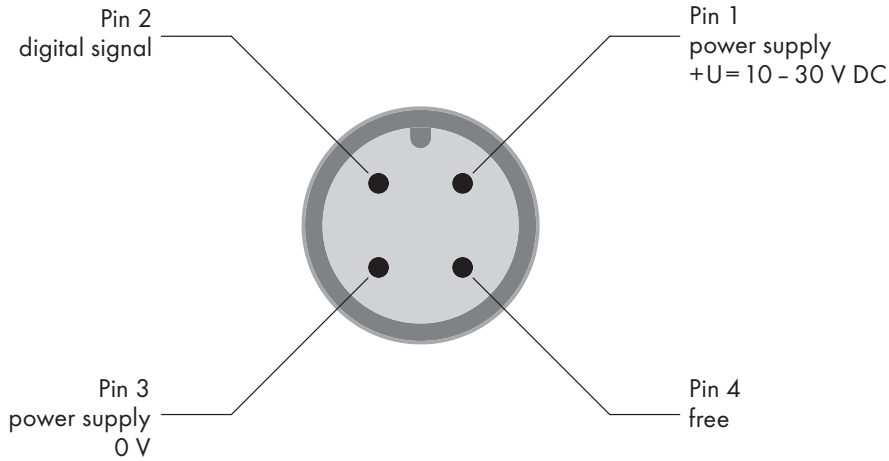

Top view of plug

Connection diagrams HT

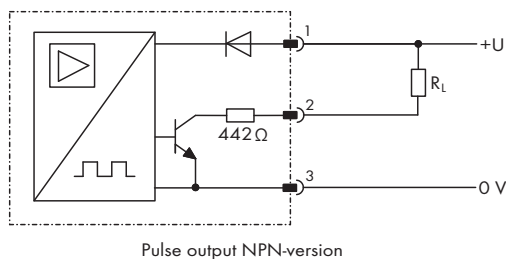
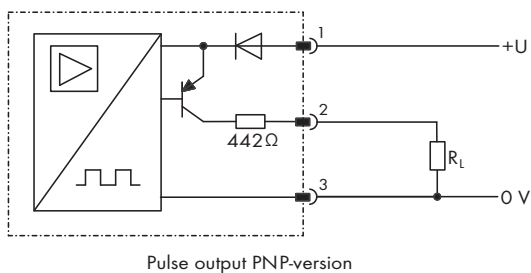
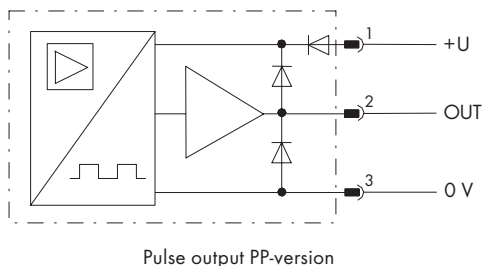

Technical specifications HT

Sensor Unit

Medium temperature	-40°C ... 210°C
Number of pick-ups	1 or 2 pick ups
Pick-up	magneto-resistive
Electrical connection	cable gland
Seals	FPM or EPDM

Amplifier pick-up system for high temperature range HTS

Supply voltage	$U_b = 10 \dots 30 \text{ V}$ DC +/- 10%
Current consumption	$I_b = \text{ca. } 18 \text{ mA}$ (idle motion, without load)
Signal output PP (Push-Pull)	High Sign.: $U_s = U_b - 1,5 \text{ V}$; Low Sign.: $U_s = 0 \text{ V}$; $I_s = 100 \text{ mA max}$
Signal output PNP	High Sign.: $U_s = U_b - 1 \text{ V}$; $I_s = 25 \text{ mA max}$
Signal output NPN	Low Sign.: $U_s = 0 \text{ V}$; $I_s = 25 \text{ mA max}$
Electrical connection	4 pin round plug M12
Max. ambient temperature	-20°C ... 50°C
Protection - class	IP 64

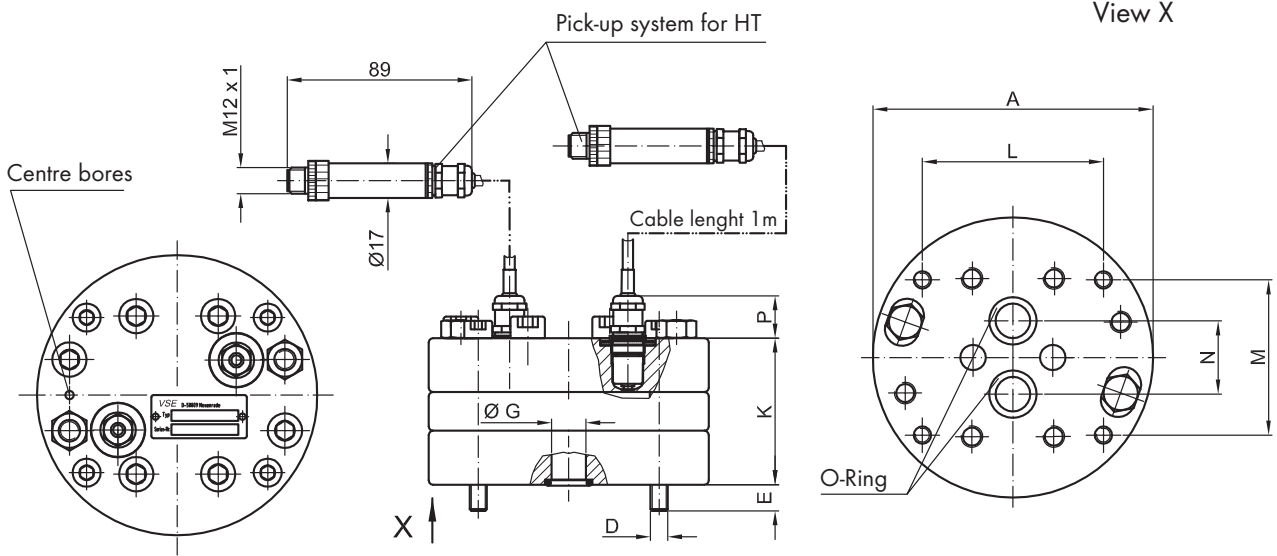

size	A	D	E	ØG	K	L	M	N	P	O-ring	Weight
VS 0.04*	100	M6	11.5	Ø 9	59	70	40	20	22	11 x 2	3.3
VS 0.1	100	M6	9	Ø 9	61	70	40	20	22	11 x 2	3.3
VS 0.2	100	M6	9.5	Ø 9	61	70	40	20	22	11 x 2	3.6
VS 0.4	115	M8	11.5	Ø 16	63.5	80	38	34	22	18 x 2.62	4.9
VS 1	130	M8	12.5	Ø 16	68	84	72	34	22	18 x 2.62	6.7
VS 2	130	M8	15	Ø 16	85	84	72	34	22	18 x 2.62	8.3
VS 4	180	M12	20	Ø 30	110	46	95	45	12	36.17 x 2.62	18.3

*only available as single-channel version

Accessories HT

Distribution cable for connection of two HT-pick-ups on a VSE-connecting cable.

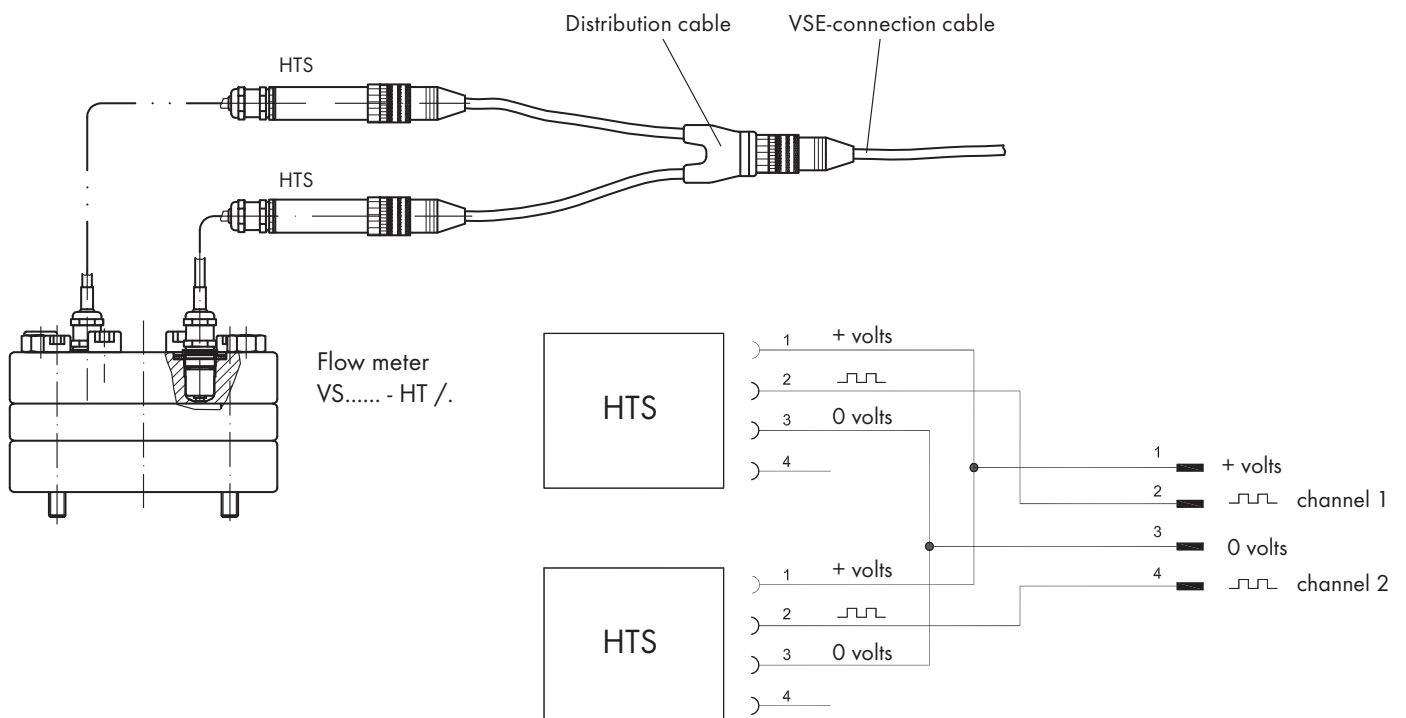



SAFETY DECLARATION FOR RETURN DELIVERIES (CERTIFICATE OF NON-OBJECTION)

Last revised: 10/2021

Please reply to info@vse-flow.com

Flow meters, for which this certificate of conformity has not been completed and signed, cannot be inspected or repaired for safety reasons and will be returned unchecked at your expense.

Article number	
Quantity	
Reason for return	

The flow meter was used in health/environmentally hazardous media.

 No

 Yes

The flow meter is free from residuals.

 No

 Yes

Special safety measures or treatment is necessary or expected.

 No

 Yes

The flow meter was last used with the following media:

If yes, which

	<input type="radio"/> No	<input type="radio"/> Yes *	
Solvents	<input type="radio"/> No	<input type="radio"/> Yes *	
Toxic liquids	<input type="radio"/> No	<input type="radio"/> Yes *	
Biologically active liquids	<input type="radio"/> No	<input type="radio"/> Yes *	
Radioactive liquids	<input type="radio"/> No	<input type="radio"/> Yes *	
Corrosive liquids	<input type="radio"/> No	<input type="radio"/> Yes *	
Alkali	<input type="radio"/> No	<input type="radio"/> Yes *	
Explosive liquids	<input type="radio"/> No	<input type="radio"/> Yes *	
Other media	<input type="radio"/> No	<input type="radio"/> Yes *	

* Please add the safety data sheet for the medium in the appendix.



SAFETY DECLARATION FOR RETURN DELIVERIES (CERTIFICATE OF NON-OBJECTION)

Please reply to info@vse-flow.com

The undersigned assures that the above information is correct and complete and the shipping is carried out according to legal regulations. The undersigned is liable for all damages which arise as a result of the non-marked decontamination of the returned flow meter.

VSE expressly points out that repairs and verification work is carried out by trusting the correctness of the completion of this safety declaration (certificate of non-objection). Should physical injuries, death or even damage to property occur, claims for damages will be asserted.

Company	
Street / Building no.	
Postcode / Town	
Phone	
Fax	
Email	

Contact
(in capitals)

Date

Signature
(company stamp)

Enclosed

VSE.flow®

VSE Volumentchnik GmbH
Hönnestraße 49
58809 Neuenrade / Germany

Phone +49 (0) 23 94 / 6 16-30

Fax +49 (0) 23 94 / 6 16-33

info@vse-flow.com

www.vse-flow.com

e.holding
FLUID TECHNOLOGY GROUP

www.e-holding.de